

SPOT PALCO WallWasher

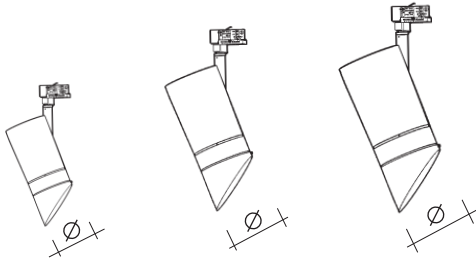

Small Ø102 mm
Medium Ø122 mm
Large Ø142 mm

IT ATTENZIONE:

LA SICUREZZA DELL'APPARECCHIO E' GARANTITA SOLO CON L'USO APPROPRIATO DELLE SEGUENTI ISTRUZIONI; PERTANTO E' NECESSARIO CONSERVARLE.

EN WARNING:

THE SAFETY OF THIS FIXTURE IS GUARANTEED ONLY IF YOU COMPLY WITH THESE INSTRUCTIONS; REMEMBER TO CONSERVE IN A SAFE PLACE.

FR ATTENTION:

LA SÛCURITÛ DE L'APPAREIL N'EST GARANTIE QU'EN CAS D'UTILISATION CORRECTE DES INSTRUCTIONS SUIVANTES; IL FAUT PAR CONSEQUENT LES CONSERVER.

DE ACHTUNG:

DIE SICHERHEIT DES GERÄTES WIRD NUR DURCH SACHGEMÄSSE BEFOLGUNG NACHSTEHENDER ANWEISUNGEN GEWÄHRLEISTET; IHRE AUFBEWAHRUNG IST DESHALB SEHR WICHTIG.

NL OPGELET:

DE VEILIGHEID VAN DI ATOESTEL IS SLECHTS DAN GEGARANDEERD ALS INDIEN DE VOLGENDE INSTRUCTIES STRIKT WORDEN TOEGEPAST: DAAROM MOET MEN ZE OOK BEWAREN.

ES ATENCION:

LA SEGURIDAD DEL APARATO SE GARANTIZA SOLO CUMPLIENDO CUIDADOSAMENTE LAS SIGUIENTES INSTRUCCIONES; POR ELLO, ES NECESARIO CONSERVARLAS.

DA BEMÆRK:

SIKKERHEDEN VED BRUG AF ARMATURET KAN KUN GARANTERES, HVIS DISSE ANVISNINGER FØLGES; SÅRIG DERFOR FOR AT GEMME DEM.

NO ADVARSEL:

SIKKERHETEN TIL DETTE APPARATET GARANTERES KUN HVIS DU OVERHOLDER DISSE INSTRUKSJONENE; HUSK E OPPBEVARE DEM PE ET TRYGT STED.

SV OBSERVERA!

UTRUSTNINGENS SÄKERHET KAN ENDAST GARANTERAS OM DESSA ANVISNINGAR RESPEKTERAS I DETALJ. SPARA DÄRFÖR DESSA ANVISNINGAR FÖR FRAMTIDA KONSULTATION.

RU ВНИМАНИЕ:

МЫ ГАРАНТИРУЕМ БЕЗОПАСНУЮ ЭКСПЛУАТАЦИЮ ИЗДЕЛИЯ ТОЛЬКО ПРИ СОБЛЮДЕНИИ СЛЕДУЮЩИХ ИНСТРУКЦИЙ; С ЭТОЙ ЦЕЛЬЮ НЕОБХОДИМО СОХРАНИТЬ ДАННУЮ БРОШЮРУ.

ZH 警告

为确保该装置安全，请遵守操作指示；并于安全场所放置。

N.B.: DURANTE L'INSTALLAZIONE DEL SISTEMA RISPETTARE SCRUPolosAMENTE LE NORME IMPIANTISTICHE VIGENTI.

N.B.: WHEN INSTALLING THE SYSTEM, STRICTLY COMPLY WITH ALL REGULATIONS ON INSTALLATION IN FORCE.

N.B.: LORS DEL'INSTALLATION DU SYSTÈME VEUILLEZ RESPECTER RIGOREUSEMENT LES NORMES EN VIGUEUR EN LA MATIÈRE.

NB: BEACHTEN SIE BEI DER INSTALLATION DES SYSTEMS GEWISSENHAFT DIE GÜLTIGEN BESTIMMUNGEN BEZÜGLICH DER ANLAGENTECHNIK.

N.B.: BIJ HET INSTALLEREN VAN HET SYSTEEM MOET U DE GELDEN DE INSTALLATIE-NORMEN STRIKT NALEVEN.

N.B.: DURANTE LA INSTALACIÓN DEL SISTEMA RESPETAR E SCRUPolosAMENTE LAS NORMAS DE INSTALACIÓN VIGENTES.

N.B.: UNDER INSTALLATION AF SYSTEMET SKAL MAN NØJE OVERHOLDE DE GÆLDENDE REGLER FOR DISSE ANLÆG.

N.B.: VED INSTALLASJON AV SYSTEMET SKAL ALLE FORSKRIFTER OM INSTALLASJON SOM GJELDER FØLGES STRENGT.

OBS! UNDER INSTALLATIONEN AV SYSTEMET SKA INSTALLATIONSFÖRESKRIFTERNA RESPEKTERAS I DETALJ.

ПРИМЕЧАНИЕ: В ПРОЦЕССЕ МОНТАЖА СИСТЕМЫ СТРОГО СОБЛЮДАЙТЕ НАЦИОНАЛЬНЫЕ ДЕЙСТВУЮЩИЕ НОРМАТИВЫ ПО ЭЛЕКТРОПРОВОДКЕ.

注意：在安装系统时请遵守设备的安装规定。

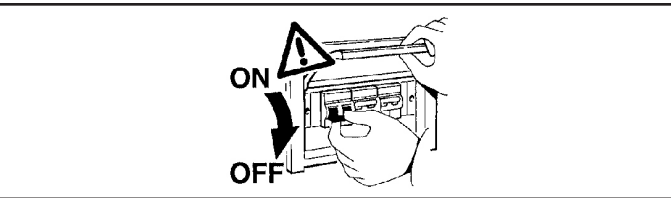
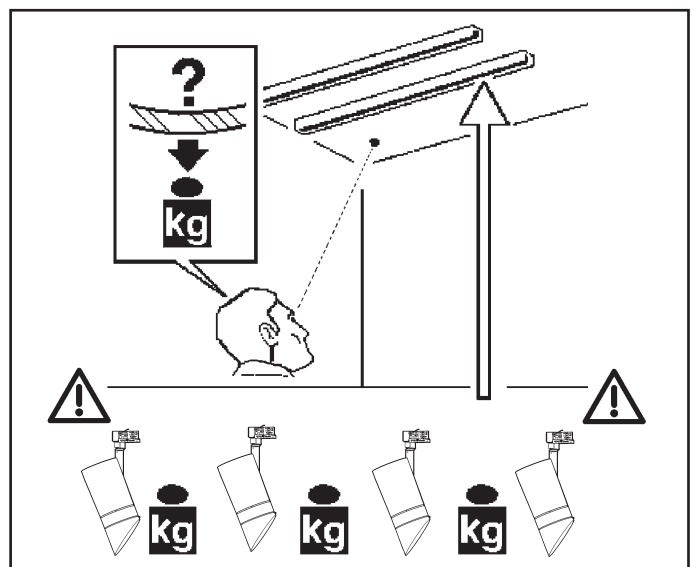
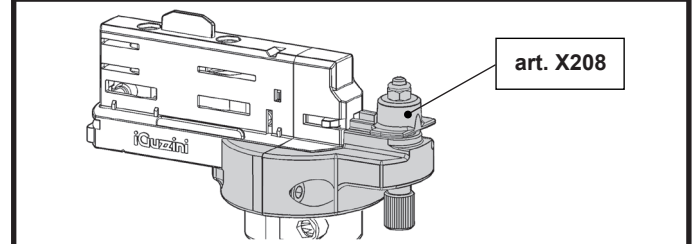
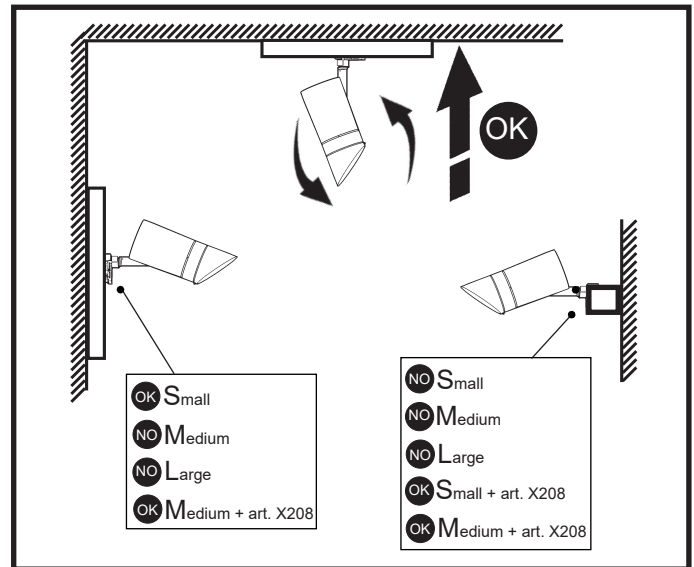
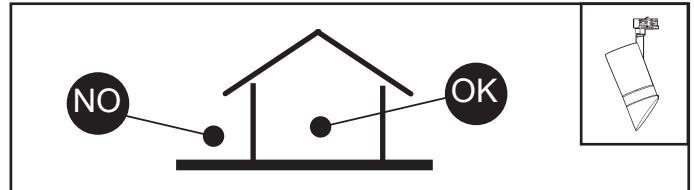

IT	Il funzionamento dei prodotti è garantito solo con l'utilizzo di binari ed accessori iGuzzini
EN	Correct product operation is only guaranteed if iGuzzini tracks and accessories are used.
FR	Le fonctionnement des produits n'est garanti qu'en cas d'utilisation de rails et accessoires iGuzzini
DE	Die Funktion der Produkte ist nur mit dem Einsatz von Schienen und Zubehör iGuzzini gewährleistet
NL	De werking van de producten wordt alleen gegarandeerd bij het gebruik van iGuzzini rails en accessoires.
ES	El funcionamiento de los productos se garantiza solamente si se utilizan railes y accesorios iGuzzini.
DA	Produktet er kun garanteret med brug af iGuzzini-skinner og -udstyr.
NO	Produktenes korrekte drift garanteres bare ved bruk av spor og tilbehør fra iGuzzini
SV	Produkternas funktion garanteras endast vid användning av spår och tillbehör från iGuzzini
RU	Функционирование продуктов гарантировано только при использовании бинариев и аксессуаров iGuzzini
ZH	此产品的正常运行只有在在使用IGUZZINI的轨道及配件的情况下才可以保证

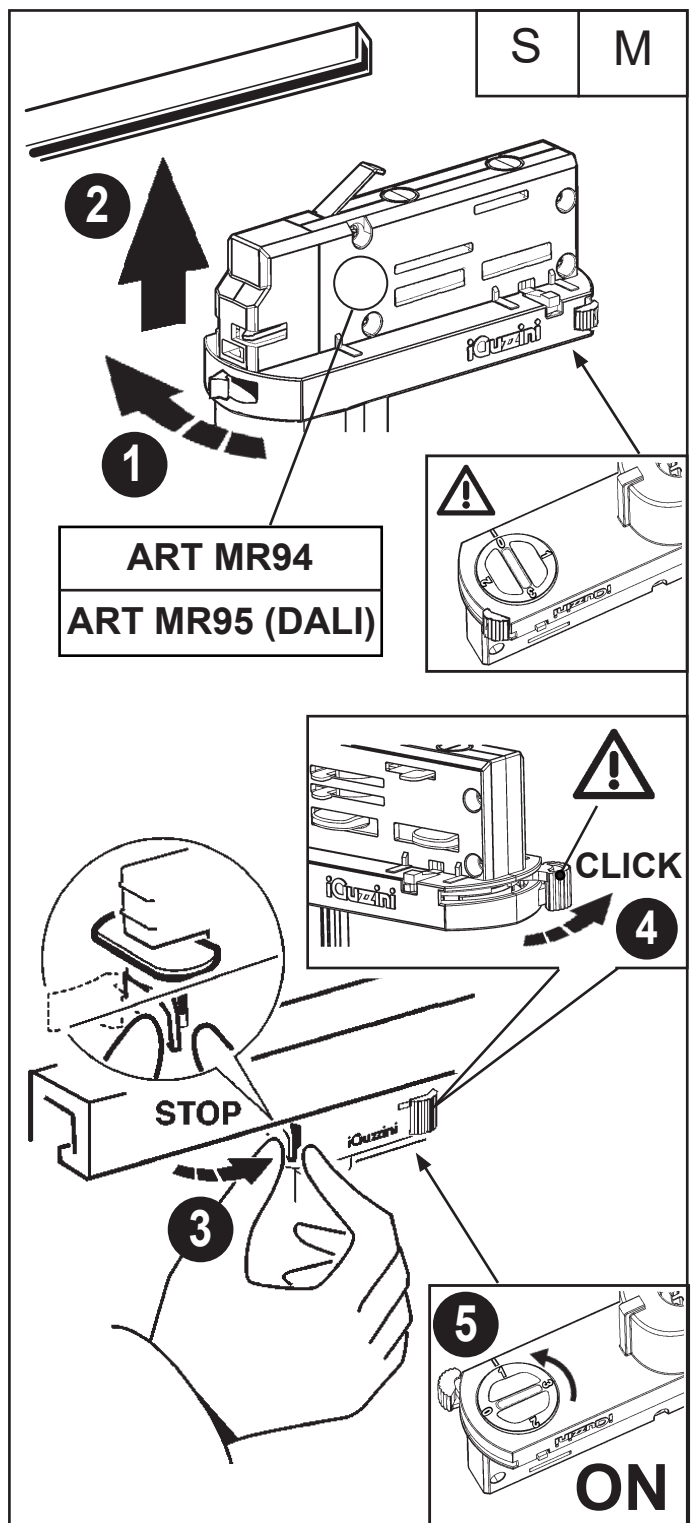
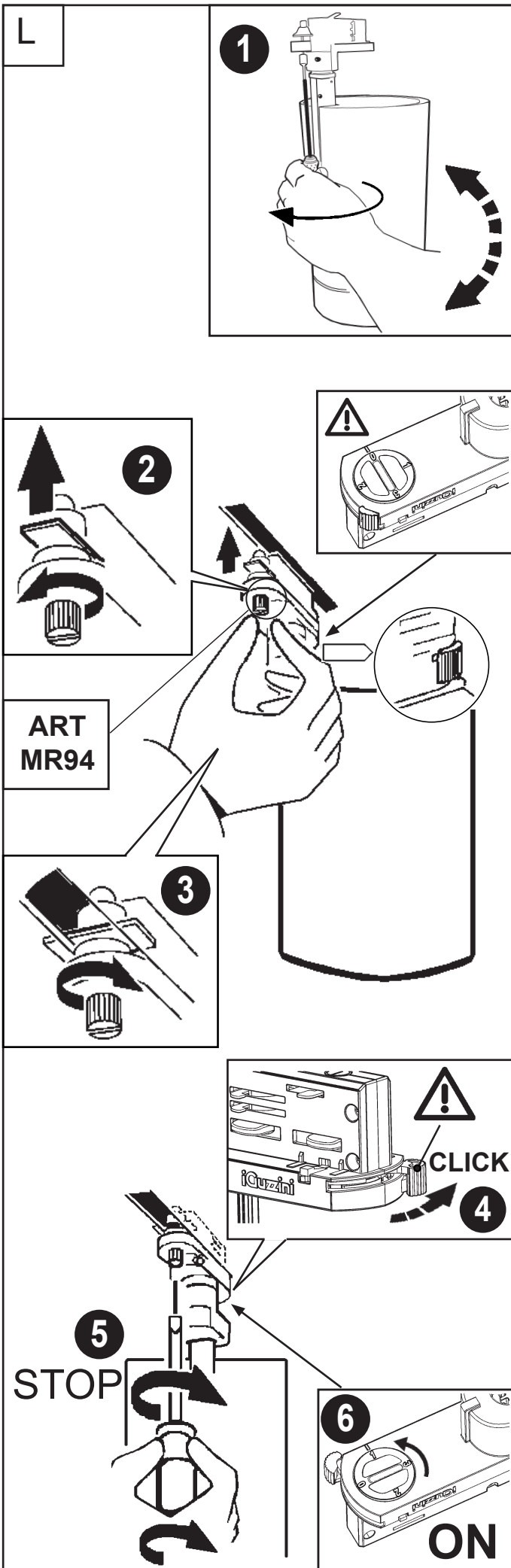

IT Sul binario DALI iGuzzini è possibile utilizzare solo prodotti DALI iGuzzini. I prodotti DALI iGuzzini possono essere utilizzati solo su binari DALI iGuzzini.

EN The iGuzzini DALI track may only be used in conjunction with iGuzzini DALI products. iGuzzini DALI products may only be used in conjunction with iGuzzini DALI tracks.

FR Sur le rail DALI iGuzzini on en peut utiliser que des produits DALI iGuzzini. Les produits DALI iGuzzini ne peuvent être utilisés que sur les rails DALI iGuzzini.

DE An der DALI-Stromschiene von iGuzzini können nur DALI-fähige Leuchten von iGuzzini angeschlossen werden. Die DALI-fähigen Leuchten von iGuzzini eignen sich nur zur Verwendung an DALI-Stromschienen von iGuzzini.

NL Op de iGuzzini DALI rails is het alleen mogelijk producten iGuzzini DALI te gebruiken. De producten iGuzzini DALI mogen alleen worden gebruikt op de rails iGuzzini DALI.

ES En el rail DALI iGuzzini se pueden utilizar solamente productos DALI iGuzzini. Los productos DALI iGuzzini pueden utilizarse solamente en los railes DALI iGuzzini.

NO På skinnen DALI iGuzzini er det bare mulig å bruke DALI iGuzzini-produkter. Produktene DALI iGuzzini kan bare brukes på DALI iGuzzini-skinner.

DA På DALI iGuzzini skinnen er det kun muligt at bruge produkter fra DALI iGuzzini. DALI iGuzzini produkterne kan kun bruges på DALI iGuzzini skinnerne.

SV På DALI iGuzzini-spåret kan endast DALI iGuzzini-produkter. DALI iGuzzini-produkter kan endast användas på DALI iGuzzini-spår.

RU На шинопроводе DALI iGuzzini можно использовать только изделия DALI iGuzzini. Изделия DALI iGuzzini могут быть использованы только на шинопроводах DALI iGuzzini.

ZH 在iGuzzini DALI轨道上只可使用DALI iGuzzini的产品。DALI iGuzzini的产品只可以用在DALI iGuzzini的轨道上。

IT NON MODIFICARE I PARAMETRI DELL'ALIMENTATORE DALI IMPOSTATI DALLA "iGuzzini"

EN DO NOT CHANGE THE DALI POWER-UNIT PARAMETERS SET BY "iGuzzini"

FR NE PAS MODIFIER LES PARAMÈTRES DU BALLAST DALI DÉFINIS PAR «iGUZZINI»

DE DIE VON „iGuzzini“ EINGESTELLTEN PARAMETER DES DALI-NETZTEILS DÜRFEN NICHT VERÄNDERT WERDEN

NL NIET DE PARAMETERS VAN HET DALI-VOORSCHAKELAPPARAATWIJZIGEN DIE DOOR "iGuzzini" ZIJN INGESTELD

ES NO CAMBIAR LOS PARÁMETROS DEL ALIMENTADOR DALI PROGRAMADOS POR "iGuzzini"

NO FORETAGIKKE ÆNDRINGER PÅ PARAMETRENE FOR DALISTRØMFORSYNINGSENHEDEN INDSTILLET AF "iGuzzini"

DA PARAMETRENE SOM ER LAGT INN I DALI STRØMFORSYNINGSENHETEN FRA "iGuzzini" MÅ IKKE ENDRES

SV ÄNDRA INTE PARAMETRARNÄ FÖR REAKTORN DALI SOM HAR STÄLLTS IN AV iGuzzini

RU НЕ ИЗМЕНЯТЬ ПАРАМЕТРЫ БЛОКА ПИТАНИЯ, ЗАДААННЫЕ НА ЗАВОДЕ "iGuzzini"

ZH 请勿改变 "iGuzzini" 设置的 DALI (数字可寻址照明接口) 电源装置参数

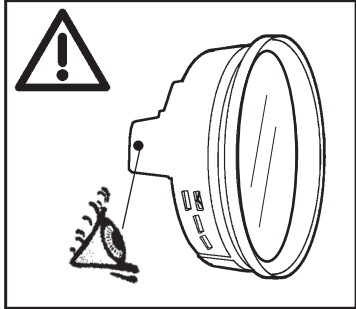
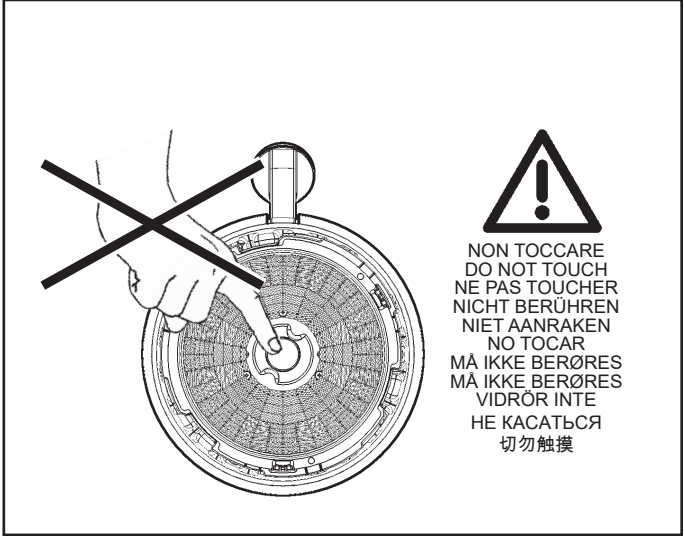
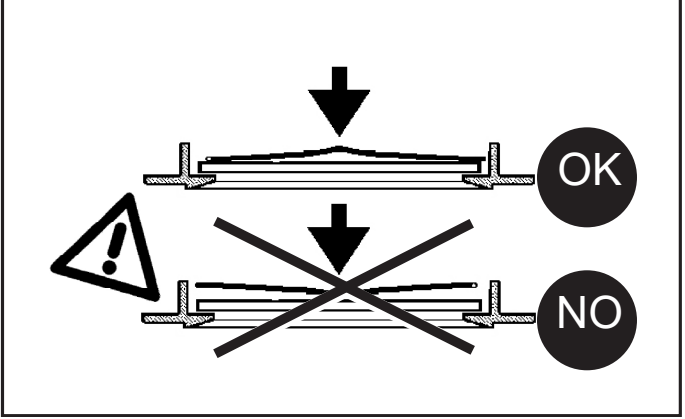
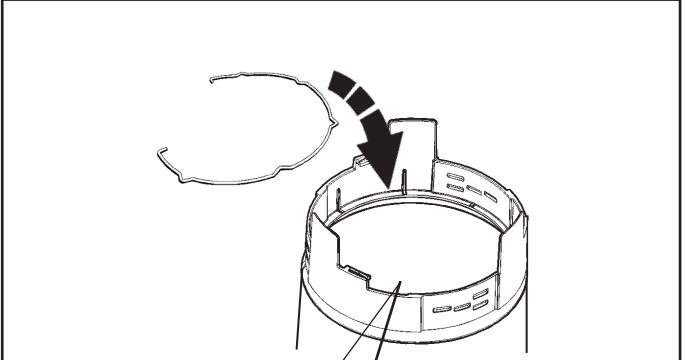

art. MR67 - MR68
MR69 - P248
P249 - P250
P211 - P212
P634 - P635
QG74 - QG75
QG76 - QG77

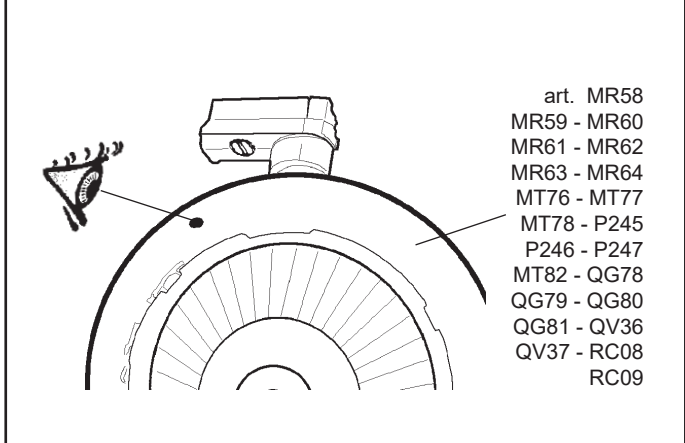
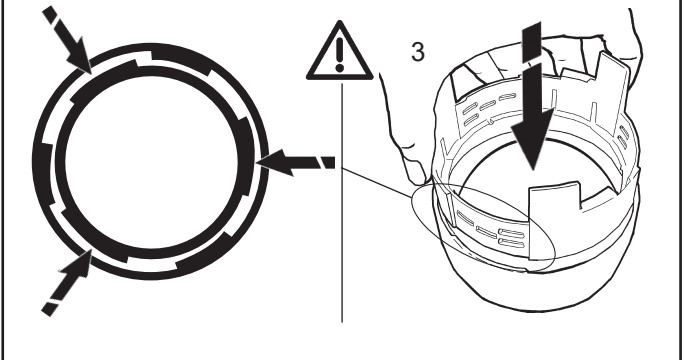
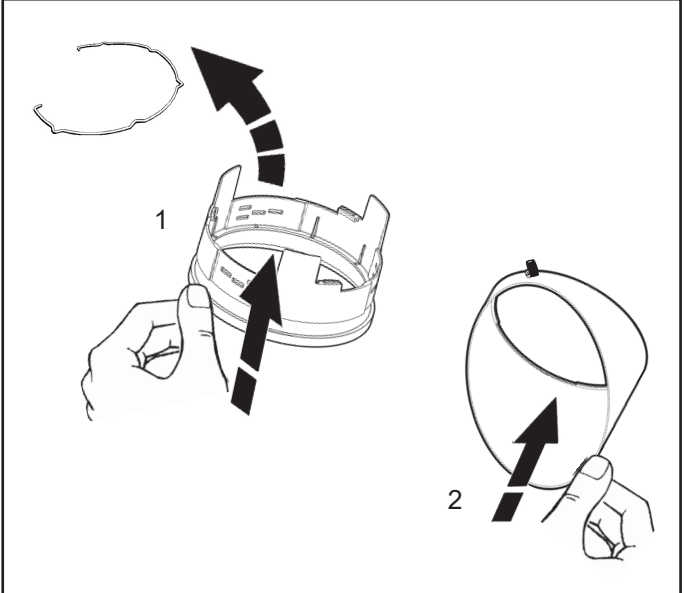
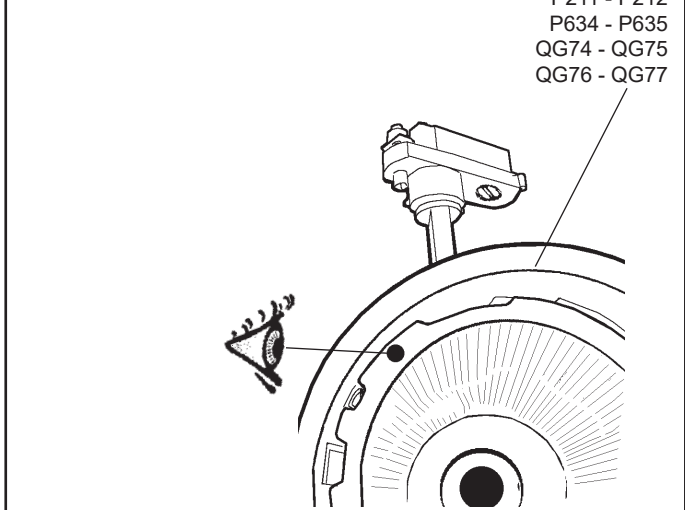

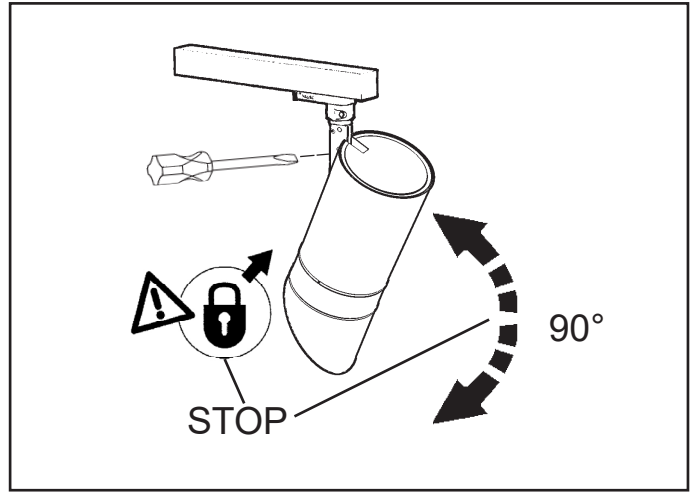
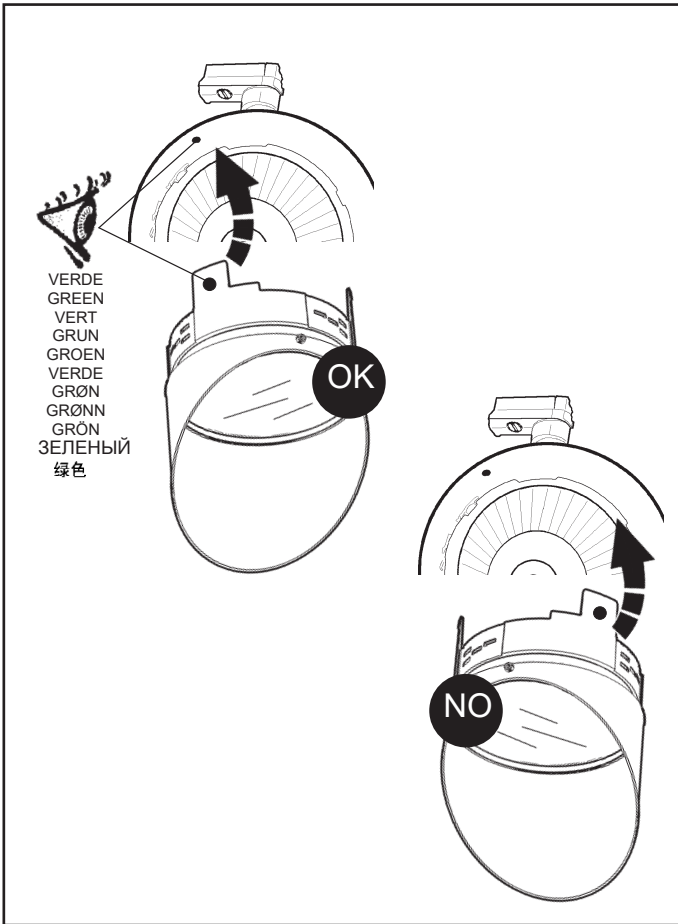

REGOLAZIONE DELL'INTENSITA' LUMINOSA - ADJUSTING THE LUMINOSITY
 RÉGLAGE DE L'INTENSITÉ LUMINEUSE - EINSTELLEN DER LICHTSTÄRKE
 HET REGELEN VAN DE LICHTSTERKTE - REGULACION DE LA INTENSIDAD LUMINOSA
 JUSTERING AF LYSSTYRKEN - JUSTERE LYSSTYRKEN - INSTÄLLNING AV LJUSSTYRKA
 НАСТРОЙКА ИНТЕНСИВНОСТИ ОСВЕЩЕНИЯ - 调整亮度

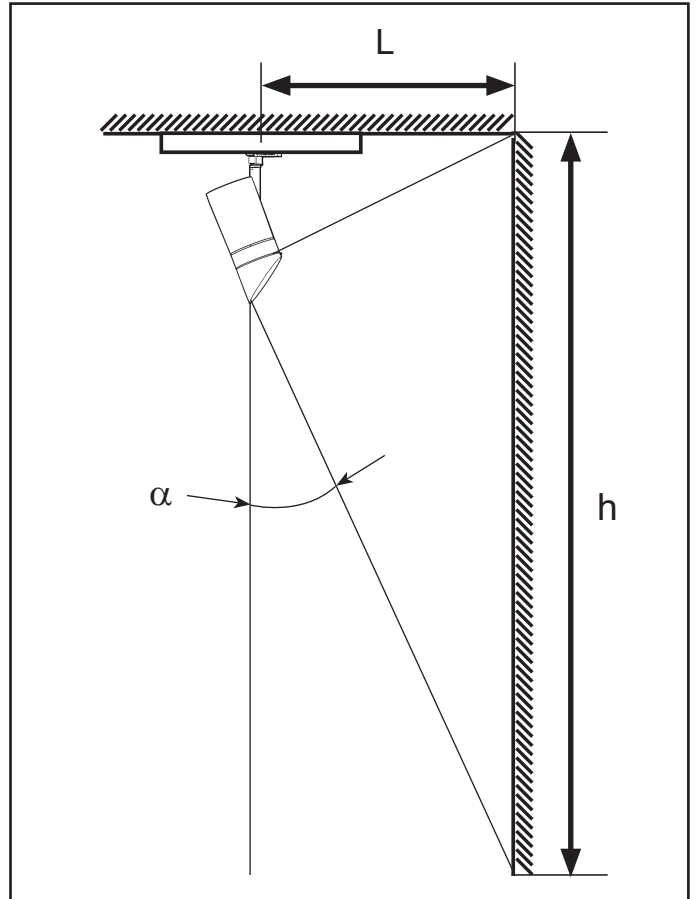
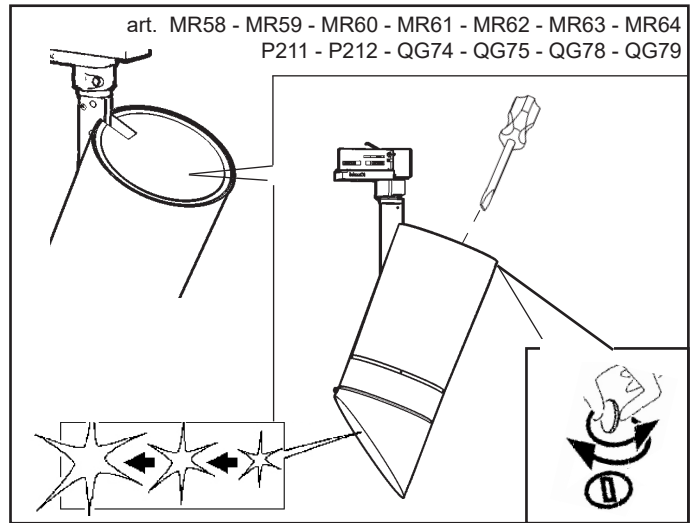

BLOCCO MECCANICO DEL PUNTAAMENTO DEL VANO - MECHANICAL LOCKING OF THE ASSEMBLY AIMING SYSTEM - VERROUILLAGE MÉCANIQUE DE L'ORIENTATION DU BLOC OPTIQUE - MECHANISCHE BLOKIERVORRICHTUNG DES LEUCHTENGEHÄUSES
 MECHANISCHE BLOKKERING VAN DE RICHTING VAN DE BEHUIZING - BLOQUEO MECÁNICO DEL PUNTO DE ENFOQUE DEL CUERPO - MEKANISK LÅS TIL OPSÆTNING AF DEN OPTISKE ENHEDS RETNING - MEKANISK LÅSING AV DET OPTISKE ROMMETS RETNING - MEKANISK BLOCKERING AV DET OPTISKA RUMMETS RIKTNING
 МЕХАНИЧЕСКАЯ БЛОКИРОВКА ОРИЕНТАЦИИ ОТСЕКА - 装配瞄准系统的机械闭锁

IT Se necessario, è possibile bloccare l'orientamento del vano ottico tramite le operazioni "STOP"
 EN If necessary, it is possible to fix the optical assembly by steps "STOP"
 FR Si nécessaire, il est possible de bloquer l'orientation du groupe optique en effectuant les opérations "STOP".
 DE Falls nötig, kann das Optikgehäuse mittels der Operationen "STOP" blockiert werden.
 NL Indien noodzakelijk kunt u de richting van het verlichtingsarmatuur vastzetten door de handelingen "STOP" uit te voeren.
 ES De ser necesario es posible detener la orientación de la óptica, efectuando las operaciones "STOP".
 DA Hvis det er nødvendigt, kan man fastlåse retningen på den optiske enhed ved at følge fremgangsmåden i "STOP"
 NO Ved behov, er det mulig å feste den optiske enheten ved trinn "STOP".
 SV Om det är nödvändigt går det att blockera det optiska rummets riktning med momenten "STOP"
 RU При необходимости можно заблокировать направление оптического проема с помощью операций "STOP".
 ZH 需要时, 可以按照 "STOP" 号操作来固定光学组装位置。

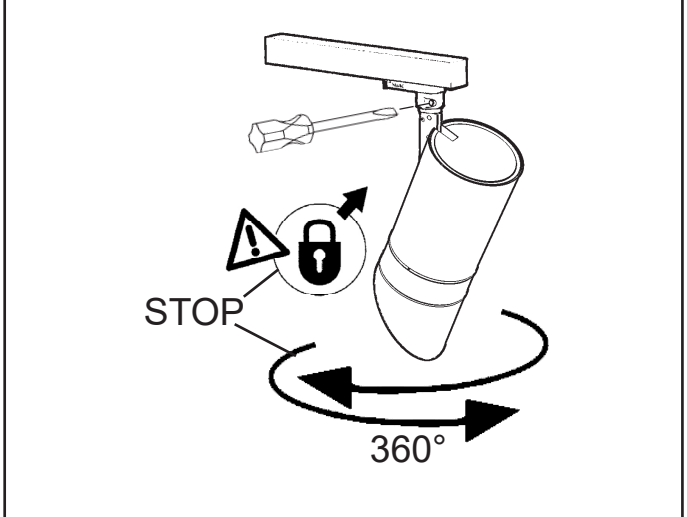

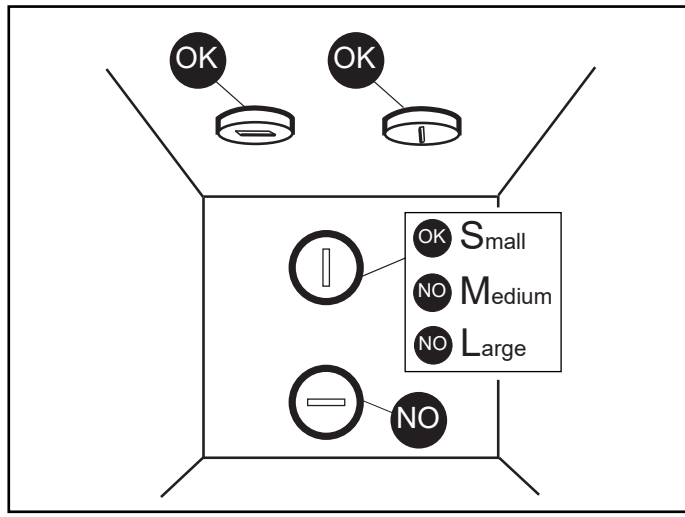
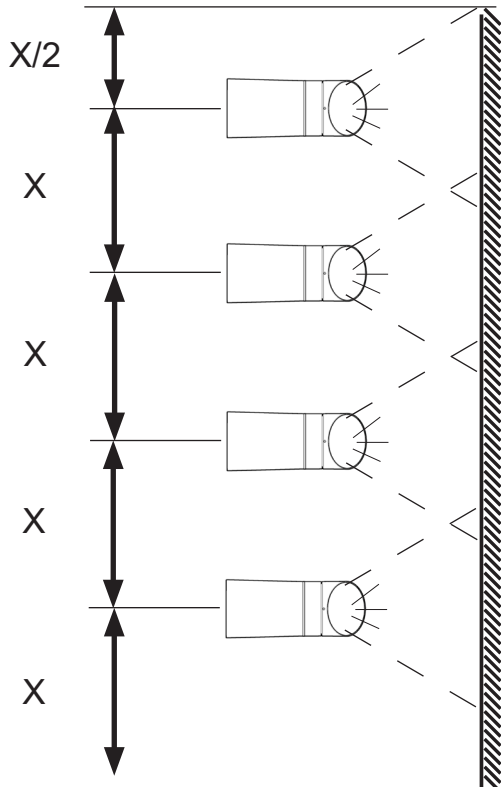

IT Per l'installazione con gli accessori art. MXZ2 - MXZ3 fare riferimento al foglio istruzioni relativo.

EN To install the product with accessories MXZ2 - MXZ3, please see the relevant instruction sheet.

FR En cas d'installation avec les accessoires art. MXZ2 - MXZ3, se conformer aux instructions de la feuille d'instructions correspondante.

DE Bezüglich der Installation mit den Zubehörteilen Art. MXZ2 - MXZ3 ziehen Sie das entsprechende Unterweisungsblatt zu Rate.

NL Voor het installeren van de accessoires art. MXZ2 - MXZ3 kunt u het betreffende instructieblaadje raadplegen.

ES Para la instalación con los accesorios art. MXZ2 - MXZ3 hágase referencia a la hoja de instrucciones.

NO For installation af ekstraudstyr art. MXZ2 - MXZ3 henvises til den pågældende brugsanvisning.

DA For installation af tilbehøret MXZ2 - MXZ3, vennligst se tilhørende instruksjonsark.

SV Angående installation med tillbehören MXZ2 - MXZ3 hänvisas till respektive instruktionsblad.

RU Порядок монтажа аксессуаров арт. MXZ2 - MXZ3 смотрите в соответствующих инструкциях.

ZH 安装配备附件 MXZ2 - MXZ3 的产品时, 请参阅相关说明表。



SOSTITUZIONE DEL LED - REPLACING THE LED
REPLACEMENT DE LA LED - AUSTAUSCHEN DER LED
VERVANGEN VAN DE LED - REEMPLAZO DEL LED
UDSKIFTNING AF LYSDIODE - BYTTE AV LYSDIOD
UTSKIFTNING AV DEN LYSEMITTERENDE DIODEN
Замена светодиода - 发光二极管替换

art. MR58 - MR59 - MR60 - MR61 - MR62 - MR63 - MR64 - MR67
 MR68 - MR69 - MT76 - MT77 - MT78 - P245 - P246 - P247 - MT82
 P248 - P249 - P250 - P211 - P212 - P634 - P635 - QG74 - QG75
 QG76 - QG77 - QG78 - QG79 - QG80 - QG81 - QV36 - QV37
 RC08 - RC09

IT N.B.: Per la sostituzione del LED contattare l'azienda iGuzzini.

EN N.B.: For information on LED replacement please contact iGuzzini.

FR N.B.: Pour procéder au remplacement de la LED, adressez-vous à la société iGuzzini.

DE Ñ.B.: Bezüglich des Austausches der LED kontaktieren Sie bitte die Firma iGuzzini.

NL N.B.: Voor het vervangen van de LED neemt u contact op met het bedrijf iGuzzini.

ES NOTA: Para sustituir el LED llame a la empresa iGuzzini.

DA N.B.: For udskiftning af lysdioden, skal man kontakte iGuzzini.

NO N.B.: For informasjon om skifte av LED, vennligst ta kontakt med iGuzzini.

SV OBS! För byte av lysdioden, kontakta företaget iGuzzini.

RU ПРИМЕЧАНИЕ: Для замены СИДов обращайтесь в компанию iGuzzini.

ZH 注意: 如需LED更换的信息, 请联系iGuzzini。

ART.	CARICO DALI / DALI LOAD CHARGE DALI (COURANT MAXI ADMISSIBLE) DALI-LAST DALI VERMOGEN CARGA DALI DALI STRØMSTYRKE BELASTNING FOR "DALI" DALI-BELASTNING МАКС. ТОК СИСТЕМЫ DALI С РЕГУЛЯЦИЕЙ ИНТЕНСИВНОСТИ СВЕТА DALI 智能调光系统允许的最大电流量	INDIRIZZI DALI DALI ADDRESSES ADRESSES DALI DALI-ADRESSEN DALI-ADRESSEN DIRECCIONES DALI DALI ADRESSER ADRESSER TIL "DALI" DALI-ADRESSER ЛОГИЧЕСКИЕ АДРЕСА СИСТЕМЫ DALI DALI智能调光系统计算机指定控制参数
P634 - P635 P245 - P246 P247 - P248 P249 - P250 QG76 - QG77 QG80 - QG81	1 (2 mA)	1

ART	(X max) m	α	(h) m	(L) m
P211 - P212 - P634 - P635 QG74 - QG75 - QG76 - QG77	0,9	30°	2,7	1
MR58 - MR59 - MR60 MT76 - MT77 - MT78	0,9	25°		
MR64 - MT82	0,8	25°		
MR61 - MR62 - MR63 - P245 P246 - P247 - QG78 - QG79 QG80 - QG81 - QV36 - QV37 RC08 - RC09	1	25°		
MR67 - MR68 - MR69 P248 - P249 - P250	1	20° - 25°		

Small Medium  + art. **MXZ2 - MXZ3** 

Large  + art. **MXZ2 - MXZ3** 

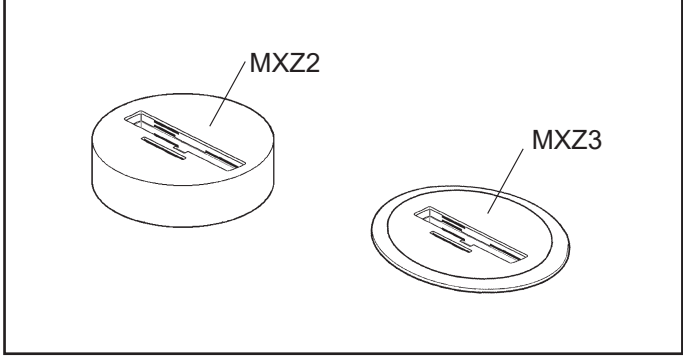

Bluetooth

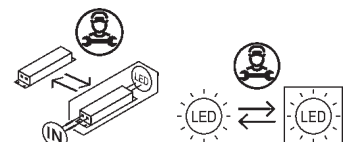
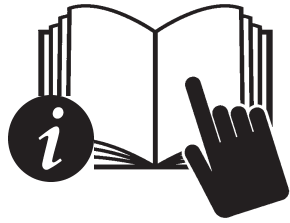

SPOT PALCO WallWasher

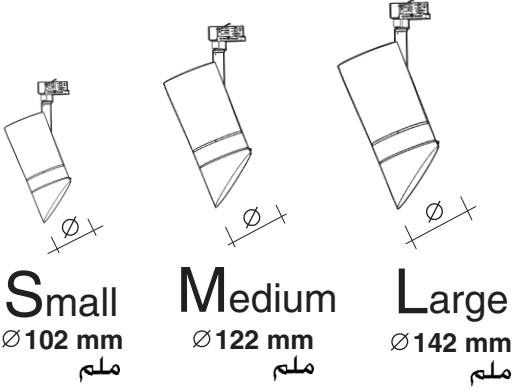

تحذير:

لا يمكن ضمان سلامة هذا الجهاز إلا إذا التزمت بهذه التعليمات. يجب حفظها في مكان آمن.

ATTENZIONE:

LA SICUREZZA DELL'APPARECCHIO E' GARANTITA SOLO CON L'USO APPROPRIATO DELLE SEGUENTI ISTRUZIONI; PERTANTO E' NECESSARIO CONSERVARLE.

WARNING:

THE SAFETY OF THIS FIXTURE IS GUARANTEED ONLY IF YOU COMPLY WITH THESE INSTRUCTIONS; REMEMBER TO CONSERVE IN A SAFE PLACE.

ATENCION:

LA SEGURIDAD DEL APARATO SE GARANTIZA SOLO CUMPLIENDO CUIDADOSAMENTE LAS SIGUIENTES INSTRUCCIONES; POR ELLO, ES NECESARIO CONSERVARLAS.

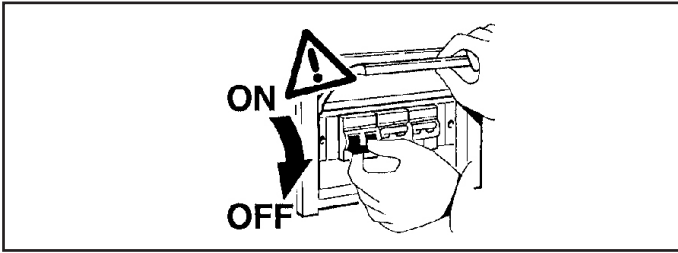

- AR iGuzzini عمل المنتجات فقط من خلال استعمال سكة ومعدات من نوع iGuzzini
- IT Il funzionamento dei prodotti è garantito solo con l'utilizzo di binari ed accessori iGuzzini
- EN Correct product operation is only guaranteed if iGuzzini tracks and accessories are used.
- ES El funcionamiento de los productos se garantiza solamente si se utilizan railes y accesorios iGuzzini.

ملاحظة: ملاحظة: أثناء تركيب نظام . يجب التقيد بحرص بالنظم السائدة المتعلقة بالشبكة الكهربائية.

N.B.: DURANTE L'INSTALLAZIONE DEL SISTEMA RISPETTARE SCRUPolosAMENTE LE NORME IMPIANTISTICHE VIGENTI.

N.B.: WHEN INSTALLING THE SYSTEM STRICTLY COMPLY WITH ALL REGULATIONS ON INSTALLATION IN FORCE.

N.B.: DURANTE LA INSTALACIÓN DEL SISTEMA RESPETAR ESCRUPolosAMENTE LAS NORMAS DE INSTALACIÓN VIGENTES.

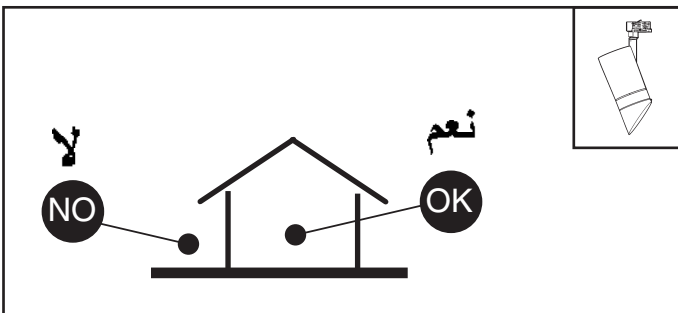
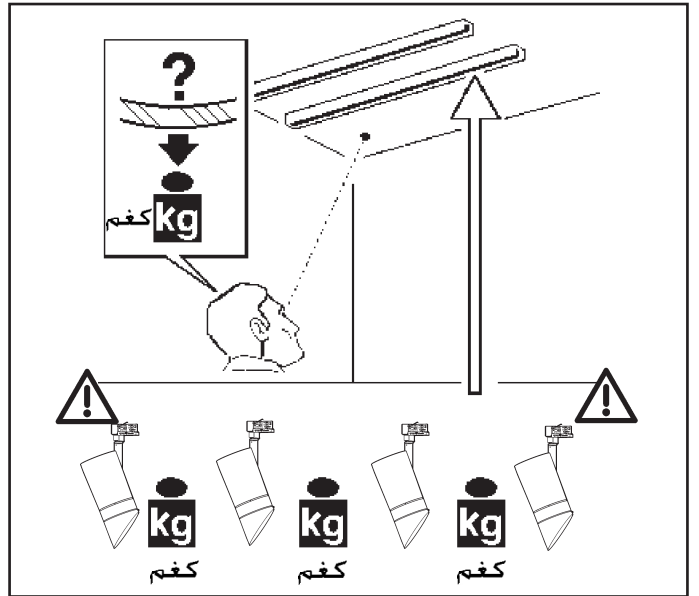
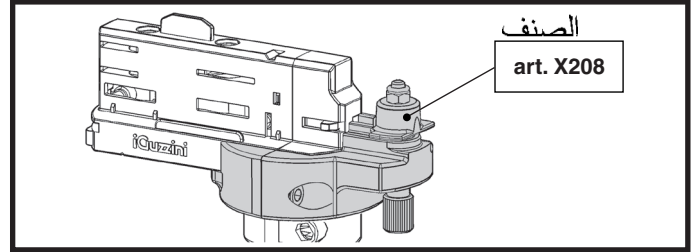
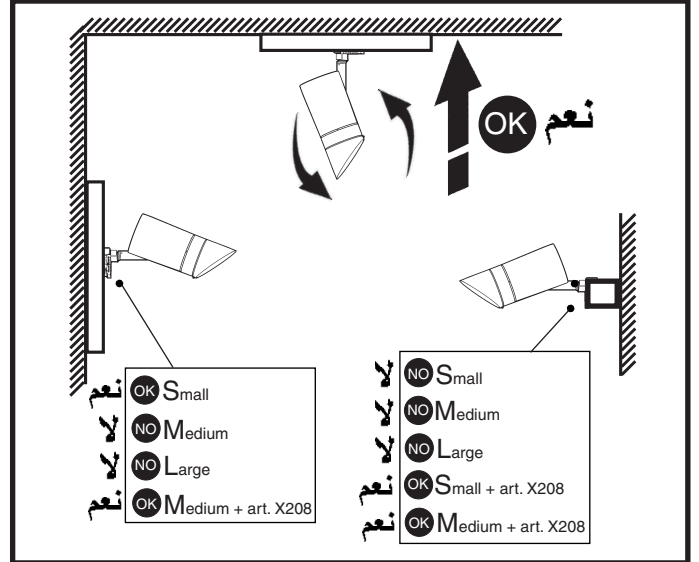

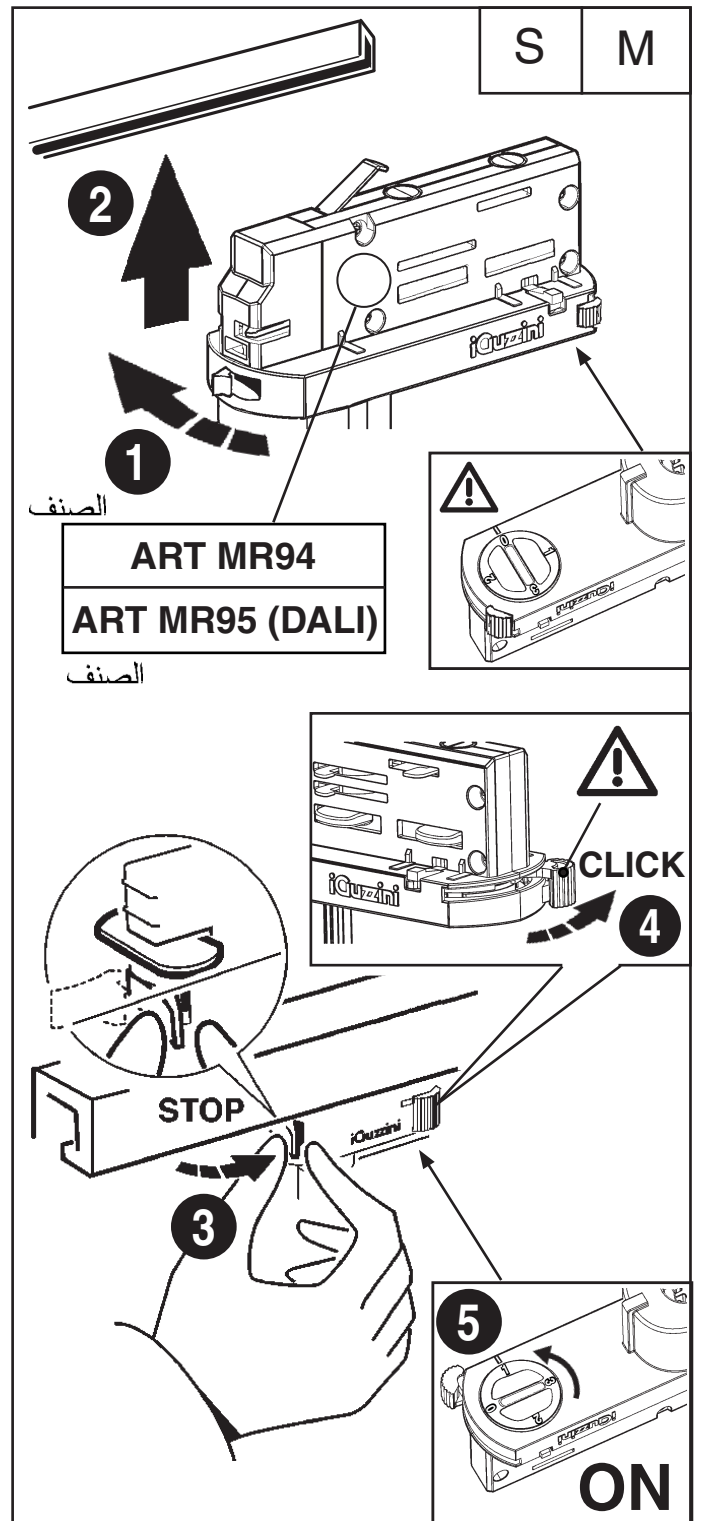
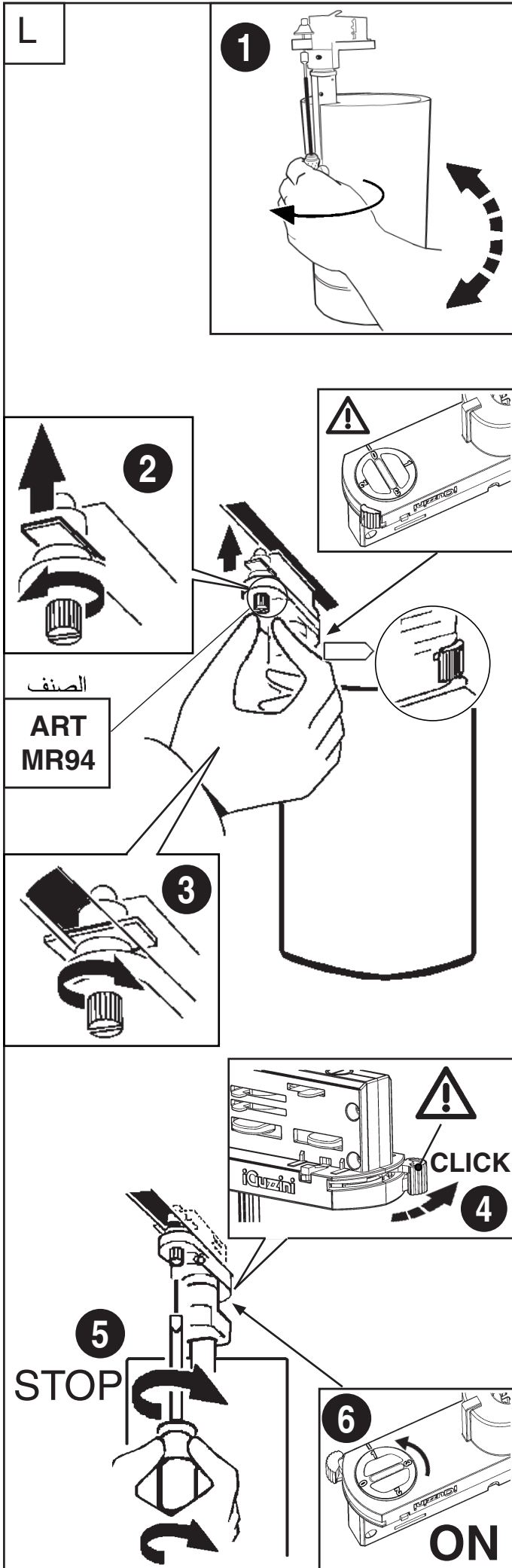

AR

يمكن استعمال على السكّة iGuzzini DALI، فقط منتجات iGuzzini DALI، منتجات iGuzzini DALI يمكن استعمالها فقط مع سكك iGuzzini DALI.

IT Sul binario DALI iGuzzini è possibile utilizzare solo prodotti DALI iGuzzini. I prodotti DALI iGuzzini possono essere utilizzati solo su binari DALI iGuzzini.

EN The iGuzzini DALI track may only be used in conjunction with iGuzzini DALI products. iGuzzini DALI products may only be used in conjunction with iGuzzini DALI tracks.

ES En el rail DALI iGuzzini se pueden utilizar solamente productos DALI iGuzzini. Los productos DALI iGuzzini pueden utilizarse solamente en los railes DALI iGuzzini.

AR

لن يتّفق نم اعدادخا بت يتلوا ؛ "بولاد" ماظن لآاب قصا خلا تيئ ابر طقلا فقا طلا تار تماراب لي دعّت بجي ال "يئني زوجي" قس مرموم

IT NON MODIFICARE I PARAMETRI DELL'ALIMENTATORE DALI IMPOSTATI DALLA "iGuzzini"

EN DO NOT CHANGE THE DALI POWER-UNIT PARAMETERS SET BY "iGuzzini"

ES NO CAMBIAR LOS PARÁMETROS DEL ALIMENTADOR DALI PROGRAMADOS POR "iGuzzini"

الصف

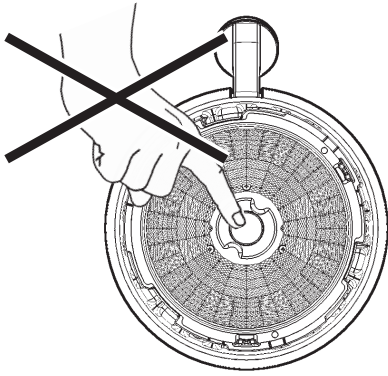

سمللا عونمم
NON TOCCARE
DO NOT TOUCH
NO TOCAR

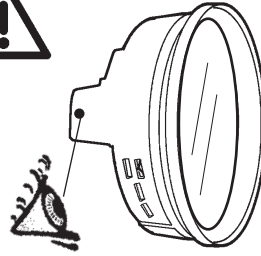

الصف

art. MR67 - MR68
MR69 - P248
P249 - P250
P211 - P212
P634 - P635
QG74 - QG75
QG76 - QG77

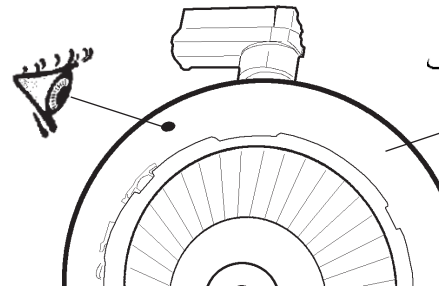
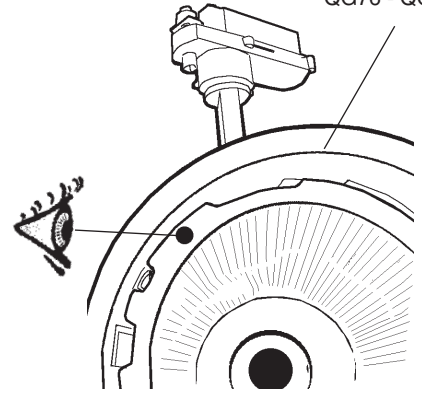

الصف art. MR58

MR59 - MR60
MR61 - MR62
MR63 - MR64
MT76 - MT77
MT78 - P245
P246 - P247
MT82 - QG78
QG79 - QG80
QG81 - QV36
QV37

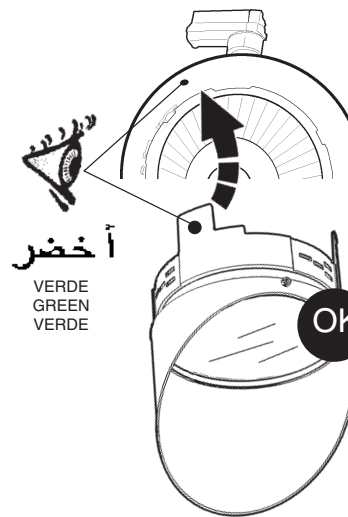

أخضر
VERDE
GREEN
VERDE

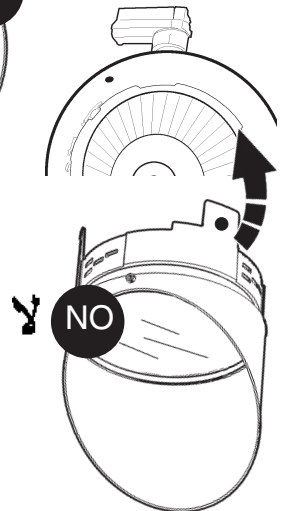

نعم

لا

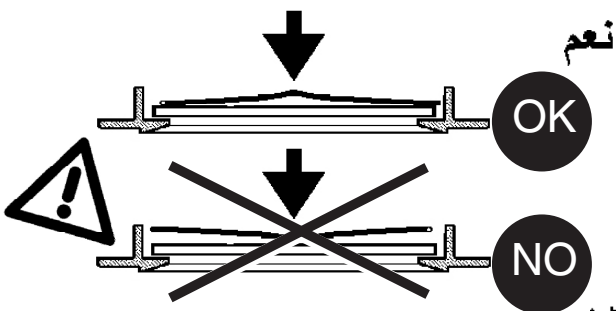
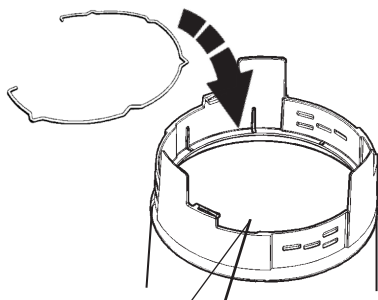
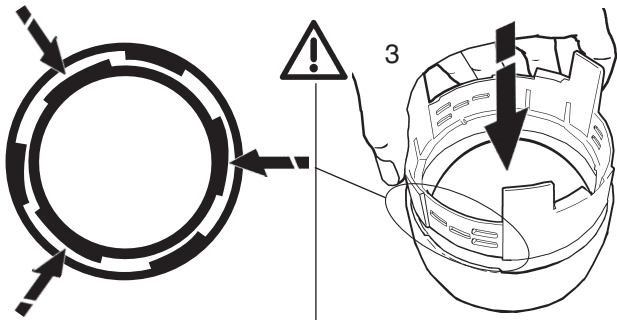
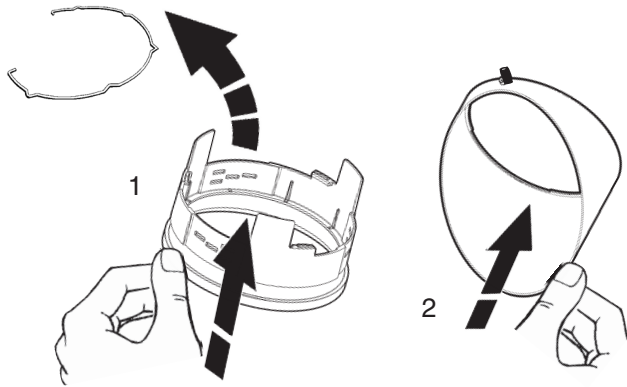

نظام تثبيت ميكانيكي لتوجيه الصندوق

BLOCCO MECCANICO DEL PUNTAMENTO DEL VANO - MECHANICAL LOCKING OF THE ASSEMBLY AIMING SYSTEM - DEL PUNTO DE ENFOQUE DEL CUERPO

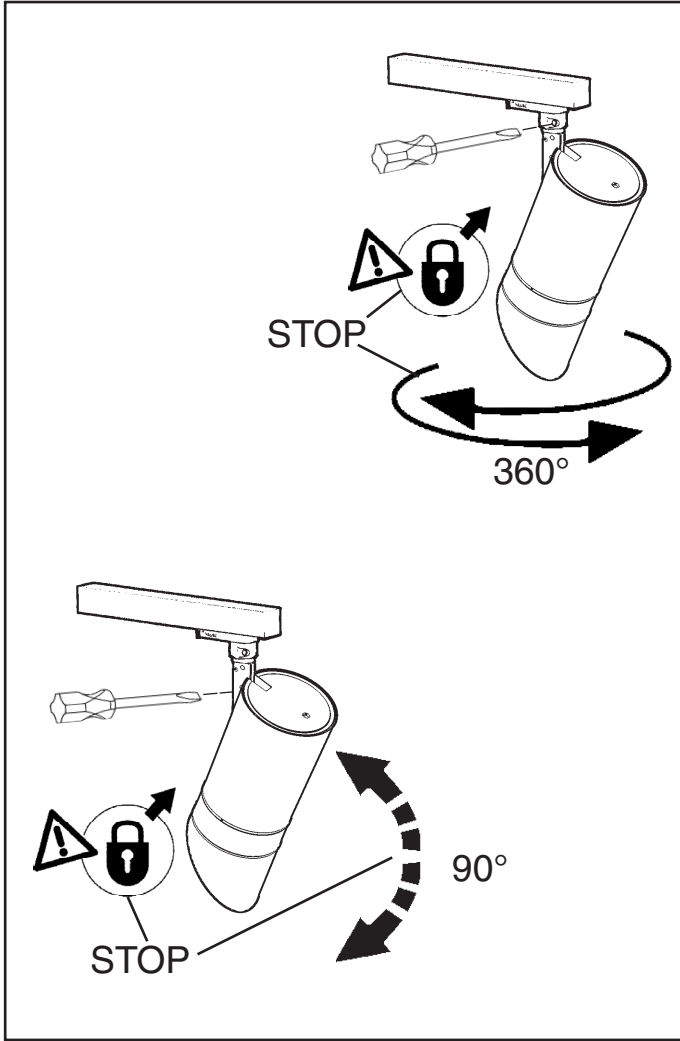

AR عند الضرورة، يمكن تثبيت توجيه الحجر البصرية من خلال العمليات "STOP"

IT Se necessario, é possibile bloccare l'orientamento del vano ottico tramite le operazioni "STOP"

EN If necessary, it is possible to fix the optical assembly by steps "STOP"

ES De ser necesario es posible detener la orientación de la Optica, efectuando las operaciones "STOP"

تعديل شدة الضوء

REGOLAZIONE DELL'INTENSITA' LUMINOSA
ADJUSTING THE LUMINOSITY
REGULACION DE LA INTENSIDAD LUMINOSA

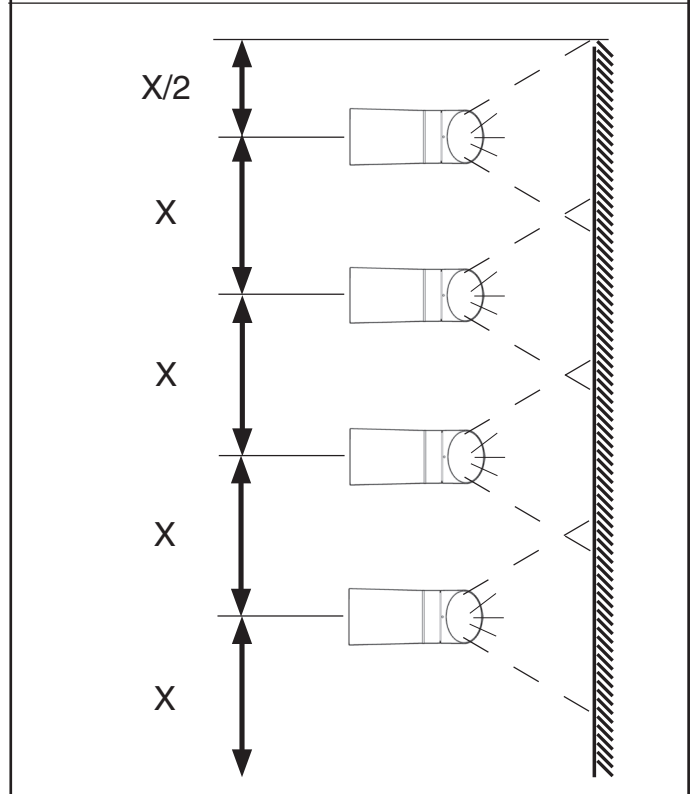
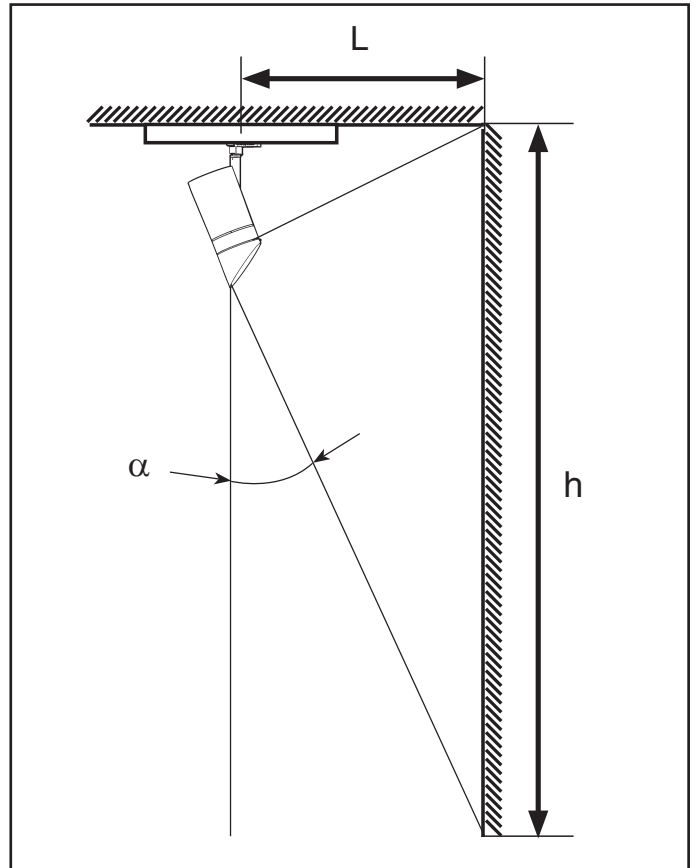
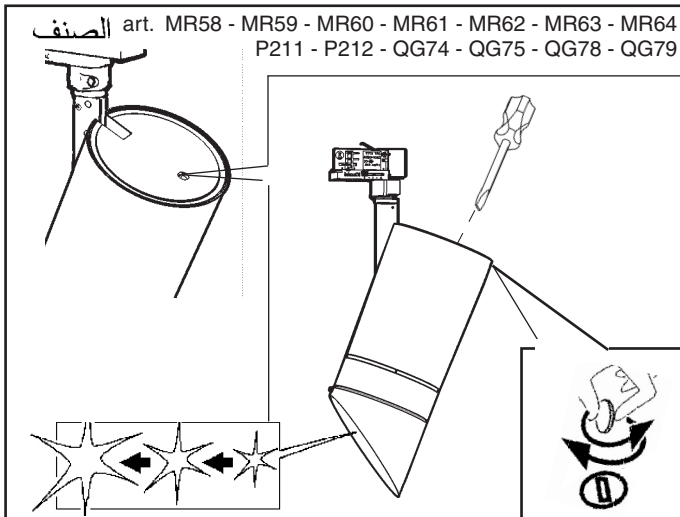

ART	(X max) m	α	(h) m	(L) m
P211 - P212 - P634 - P635 QG74 - QG75 - QG76 - QG77	0,9	30°	2,7	1
MR58 - MR59 - MR60 MT76 - MT77 - MT78	0,9	25°		
MR64 - MT82	0,8	25°		
MR61 - MR62 - MR63 - P245 P246 - P247 - QG78 - QG79 QG80 - QG81 - QV36 - QV37	1	25°		
MR67 - MR68 - MR69 P248 - P249 - P250	1	20° - 25°		

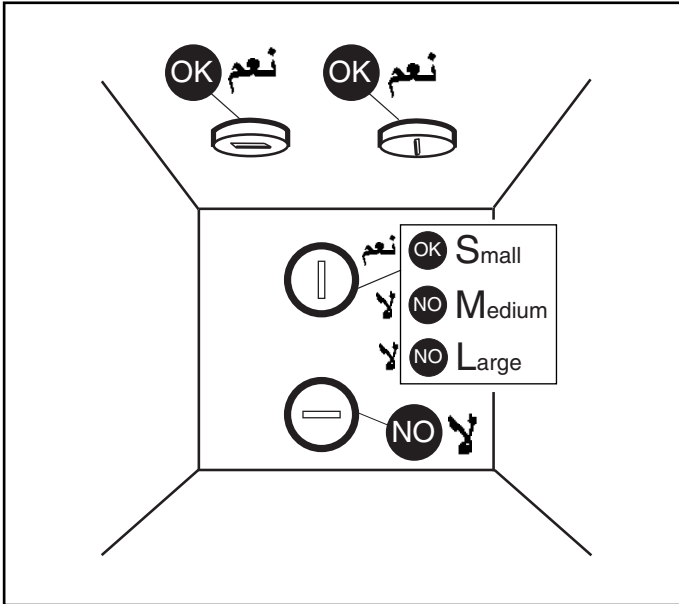
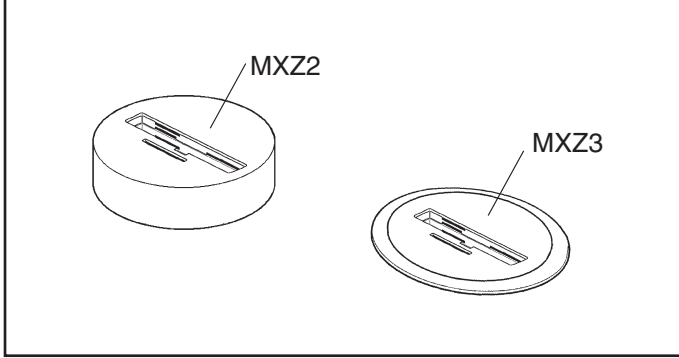

AR تركيب الملحقات، يجب مراجعة ورقة التعليمات الخاصة بها.

IT Per l'installazione con gli accessori art. MXZ2 - MXZ3 fare riferimento al foglio istruzioni relativo.

EN To install the product with accessories MXZ2 - MXZ3, please see the relevant instruction sheet.

ES Para la instalación con los accesorios art. MXZ2 - MXZ3 hágase referencia a la hoja de instrucciones.

اشارة مصباح الانذار

SEGNALAZIONI LED
LED WARNINGS
SEÑALACIONES DEL LED

art. MR58 - MR59 - MR60 - MR61 - MR62 - MR63 - MR64 - MR67
الصف MR68 - MR69 - MT76 - MT77 - MT78 - P245 - P246 - P247
MT82 - P248 - P249 - P250 - P211 - P212 - P634 - P635
QG74 - QG75 - QG76 - QG77 - QG78 - QG79 - QG80 - QG81
QV36 - QV37

AR . iGuzzini **تنبيه: لاستبدال الضوء LED اتصل بشركة**

IT N.B.: Per la sostituzione del LED contattare l'azienda iGuzzini.

EN N.B.: For information on LED replacement please contact iGuzzini.

ES NOTA: Para sustituir el LED llame a la empresa iGuzzini.

ART.	DALI شحنة / DALI جمل CARICO DALI / DALI LOAD CHARGE DALI CARGA DALI	DALI عناوين INDIRIZZI DALI DALI ADDRESSES DIRECCIONES DALI
P634 - P635 P245 - P246 P247 - P248 P249 - P250 QG76 - QG77 QG80 - QG81 QV36 - QV37	1 (2 m A)	1

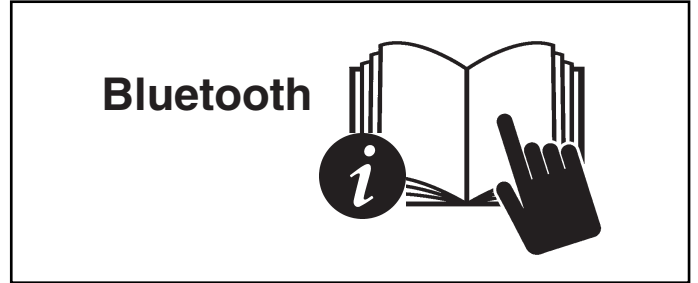

2.519.604.00
IS11579/00

iGuzzini

POSIZIONE DI INSTALLAZIONE ADATTATORE
ADAPTER INSTALLATION POSITION
POSITION D'INSTALLATION ADAPTATEUR
EINBAUPOSITION DES ADAPTERS
INSTALLATIESTAND ADAPTER
POSICIÓN DE INSTALACIÓN DEL ADAPTADOR
POSITION TIL ADAPTERENS INSTALLATION
INSTALLASJONSPOSISJON FOR ADAPTER
INSTALLATIONSPOSITION FÖR ADAPTER
ПОЛОЖЕНИЕ МОНТАЖА ПЕРЕХОДНИКА
适配器安装位置

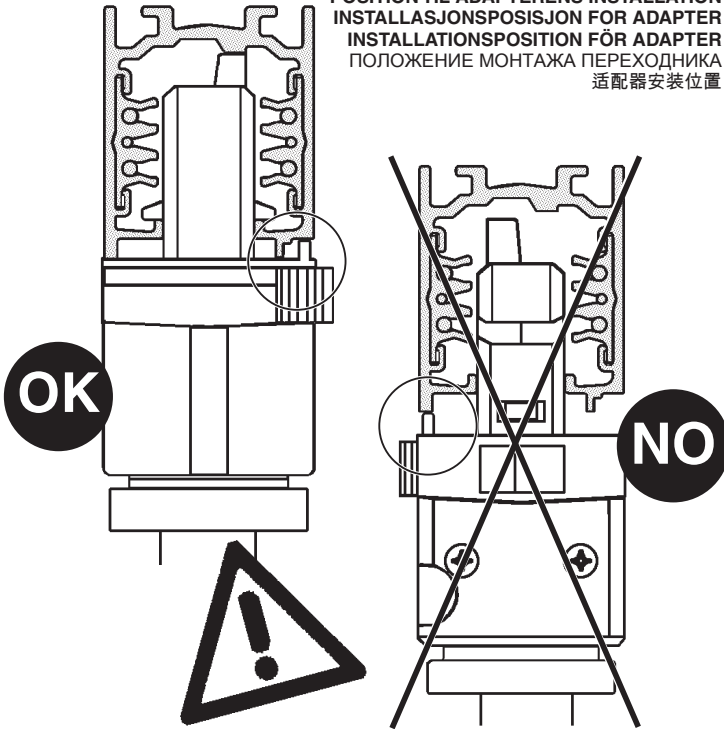

2.519.604.00
IS11579/00

iGuzzini

POSIZIONE DI INSTALLAZIONE ADATTATORE
ADAPTER INSTALLATION POSITION
POSITION D'INSTALLATION ADAPTATEUR
EINBAUPOSITION DES ADAPTERS
INSTALLATIESTAND ADAPTER
POSICIÓN DE INSTALACIÓN DEL ADAPTADOR
POSITION TIL ADAPTERENS INSTALLATION
INSTALLASJONSPOSISJON FOR ADAPTER
INSTALLATIONSPOSITION FÖR ADAPTER
ПОЛОЖЕНИЕ МОНТАЖА ПЕРЕХОДНИКА
适配器安装位置

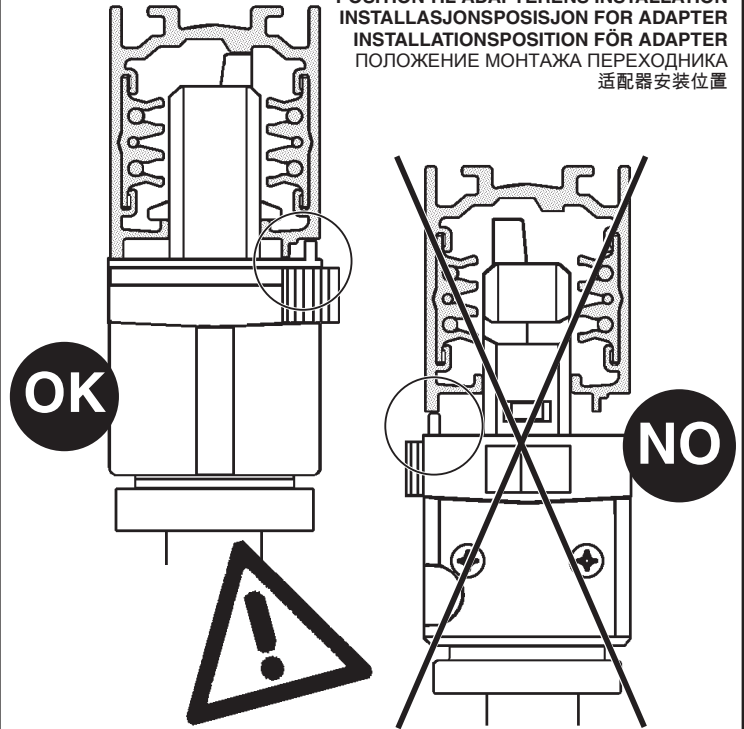

2.519.604.00
IS11579/00

iGuzzini

POSIZIONE DI INSTALLAZIONE ADATTATORE
ADAPTER INSTALLATION POSITION
POSITION D'INSTALLATION ADAPTATEUR
EINBAUPOSITION DES ADAPTERS
INSTALLATIESTAND ADAPTER
POSICIÓN DE INSTALACIÓN DEL ADAPTADOR
POSITION TIL ADAPTERENS INSTALLATION
INSTALLASJONSPOSISJON FOR ADAPTER
INSTALLATIONSPOSITION FÖR ADAPTER
ПОЛОЖЕНИЕ МОНТАЖА ПЕРЕХОДНИКА
适配器安装位置

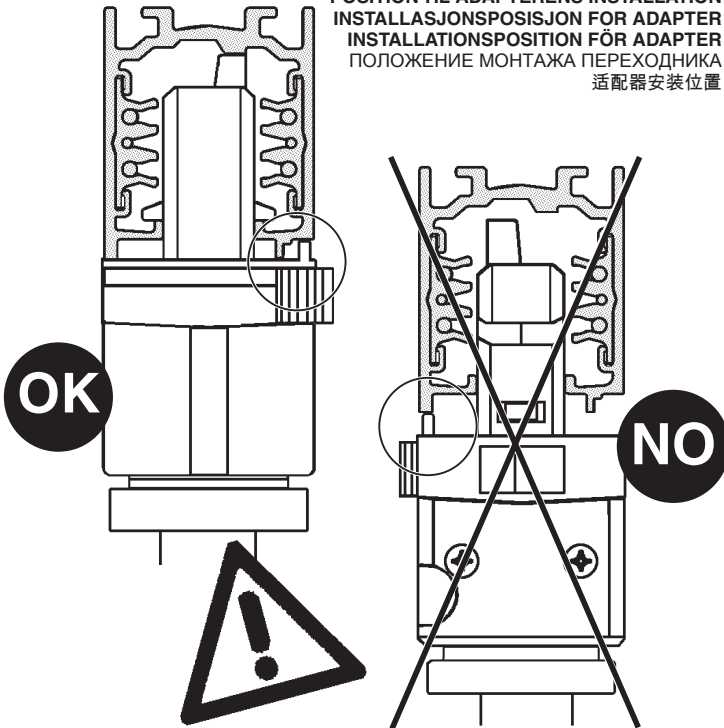

2.519.604.00
IS11579/00

iGuzzini

POSIZIONE DI INSTALLAZIONE ADATTATORE
ADAPTER INSTALLATION POSITION
POSITION D'INSTALLATION ADAPTATEUR
EINBAUPOSITION DES ADAPTERS
INSTALLATIESTAND ADAPTER
POSICIÓN DE INSTALACIÓN DEL ADAPTADOR
POSITION TIL ADAPTERENS INSTALLATION
INSTALLASJONSPOSISJON FOR ADAPTER
INSTALLATIONSPOSITION FÖR ADAPTER
ПОЛОЖЕНИЕ МОНТАЖА ПЕРЕХОДНИКА
适配器安装位置

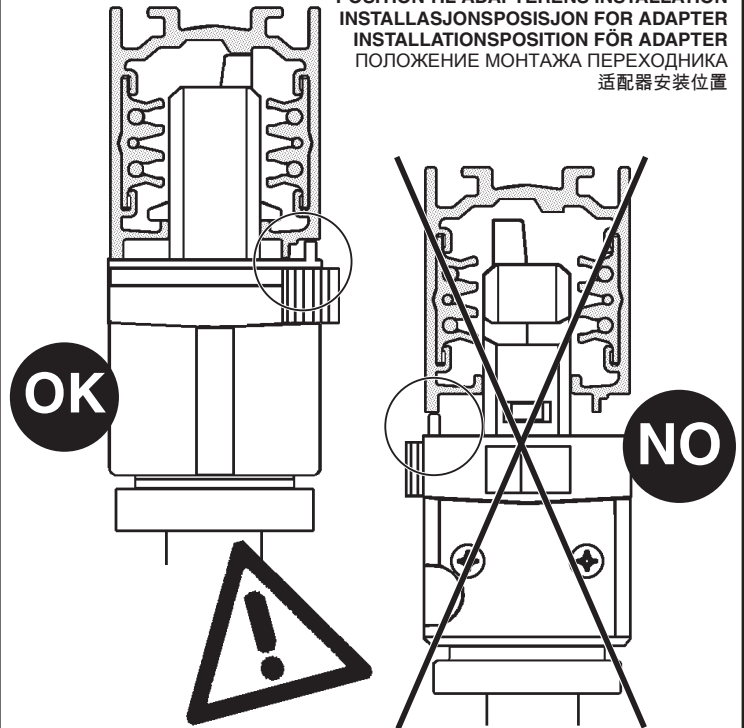

1.154.598.14 IS10226/08	iGuzini	fattore di potenza - power factor - facteur de puissance Leistungsfaktor - vermogensfactor - factor de potencia effektfaktor - effektfaktor эффектфактор - фактор мощности - 功率因数	corrente assorbita - absorbed current - courant absorbé Stromaufnahme - stroomopname corriente absorbida - absorberet ström - absorberet ström tillförd ström - потребляемая мощность - 电源电流 (A)
ART.			
MJ67 - MJ68 - MJ71 - MJ72 - MR55 MR56 - MJ66 - MJ69 - MJ70 - MJ73	>0,95	0,1	
MJ74 - MJ75 - MJ76 - MJ77 - MR57 MT42 - MT43 - MT44 - MT45 - MT77	>0,9	0,091	
MJ86 - MJ87 - MJ88 - MJ89 - MR60 MT46 - MT47 - MT48 - MT49 - MT78	>0,9	0,104	
MJ78 - MJ79 - MJ80 - MJ81 - MR58	>0,9	0,086	
MJ82 - MJ83 - MJ84 - MJ85 - MR59	>0,9	0,093	
MJ98 - MJ99 - MK00 - MK01 - MR63 QG58 - QG59 - QG60 - QG61 - QG62 QG63 - QG64 - QG65 - QG78 - QG79 RC00 - RC01 - RC02 - RC03 - RC04 RC05 - RC06 - RC07 - RC08 - RC09	>0,95	0,18	
MJ90 - MJ91 - MJ92 - MJ93 - MR61	>0,95	0,135	
MJ94 - MJ95 - MJ96 - MJ97 - MR62	>0,9	0,15	
MK02 - MK03 - MK04 - MR64	>0,95	0,14	
MK05 - MK06 - MK07 - MK08 - MR65	>0,95	0,2	
MK09 - MK10 - MK11 - MK12 - MR66	>0,95	0,24	
P242 - P243 - P244 - P250 P236 - P237 - P238 - P248	>0,95	0,25	
MK13 - MK14 - MK15 - MK16	>0,95	0,4	
MK26 - MK27 - MK28 - MR69 MK18 - MK19 - MK20 - MR67	>0,95	0,256	
MK22 - MK23 - MK24 - MR68	>0,95	0,208	
MK29 - MK30 - MK31 - MR32 - MR70 ML53	>0,95	0,3	
MK33 - MK34 - MK35 - ML52	>0,95	0,45	
MR98	>0,95	0,142	
P626 - P627 - P628 - P629 - P634	>0,95	0,118	
P207 - P208 - P209 - P210 - P212 P630 - P631 - P632 - P633 - P635 QG42 - QG43 - QG44 - QG45 - QG46 QG47 - QG48 - QG49 - QG74 - QG75 QG50 - QG51 - QG52 - QG53 - QG54 QG55 - QG56 - QG57 - QG76 - QG77	>0,95	0,127	
MT38 - MT39 - MT40 - MT41 - MT76	>0,9	0,089	
P232 - P233 - P234 - P235 - P247 QG66 - QG67 - QG68 - QG69 - QG70 QG71 - QG72 - QG73 - QG80 - QG81 QV28 - QV29 - QV30 - QV31 - QV32 QV33 - QV34 - QV35 - QV36 - QV37	>0,95	0,186	
P224 - P225 - P226 - P227 - P245	>0,95	0,147	
MT54 - MT55 - MT56 - MT57 - P246	>0,95	0,143	
MT62 - MT63 - MT64 - MT82	>0,9	0,156	
MT68 - MT69 - MT70 - P249	>0,95	0,212	
P252	>0,95	0,157	
N208	0,86	0,035	
P945	0,86	0,037	
N210	>0,9	0,065	
P946	>0,9	0,064	
N212	>0,95	0,099	
P947	>0,9	0,103	
MXJ0 - Q744	>0,95	0,105	
P251 - Q745	>0,95	0,104	
P203 - P204 - P205 - P206 - P211	>0,95	0,122	
P213 - P214 - P215 - P216 - P221	>0,95	0,083	
P217 - P218 - P219 - P220 - P222	>0,95	0,101	

1.154.598.14 IS10226/08	iGuzini	fattore di potenza - power factor - facteur de puissance Leistungsfaktor - vermogensfactor - factor de potencia effektfaktor - effektfaktor эффектфактор - фактор мощности - 功率因数	corrente assorbita - absorbed current - courant absorbé Stromaufnahme - stroomopname corriente absorbida - absorberet ström - absorberet ström tillförd ström - потребляемая мощность - 电源电流 (A)
ART.			
MJ67 - MJ68 - MJ71 - MJ72 - MR55 MR56 - MJ66 - MJ69 - MJ70 - MJ73	>0,95	0,1	
MJ74 - MJ75 - MJ76 - MJ77 - MR57 MT42 - MT43 - MT44 - MT45 - MT77	>0,9	0,091	
MJ86 - MJ87 - MJ88 - MJ89 - MR60 MT46 - MT47 - MT48 - MT49 - MT78	>0,9	0,104	
MJ78 - MJ79 - MJ80 - MJ81 - MR58	>0,9	0,086	
MJ82 - MJ83 - MJ84 - MJ85 - MR59	>0,9	0,093	
MJ98 - MJ99 - MK00 - MK01 - MR63 QG58 - QG59 - QG60 - QG61 - QG62 QG63 - QG64 - QG65 - QG78 - QG79 RC00 - RC01 - RC02 - RC03 - RC04 RC05 - RC06 - RC07 - RC08 - RC09	>0,95	0,18	
MJ90 - MJ91 - MJ92 - MJ93 - MR61	>0,95	0,135	
MJ94 - MJ95 - MJ96 - MJ97 - MR62	>0,9	0,15	
MK02 - MK03 - MK04 - MR64	>0,95	0,14	
MK05 - MK06 - MK07 - MK08 - MR65	>0,95	0,2	
MK09 - MK10 - MK11 - MK12 - MR66	>0,95	0,24	
P242 - P243 - P244 - P250 P236 - P237 - P238 - P248	>0,95	0,25	
MK13 - MK14 - MK15 - MK16	>0,95	0,4	
MK26 - MK27 - MK28 - MR69 MK18 - MK19 - MK20 - MR67	>0,95	0,256	
MK22 - MK23 - MK24 - MR68	>0,95	0,208	
MK29 - MK30 - MK31 - MR32 - MR70 ML53	>0,95	0,3	
MK33 - MK34 - MK35 - ML52	>0,95	0,45	
MR98	>0,95	0,142	
P626 - P627 - P628 - P629 - P634	>0,95	0,118	
P207 - P208 - P209 - P210 - P212 P630 - P631 - P632 - P633 - P635 QG42 - QG43 - QG44 - QG45 - QG46 QG47 - QG48 - QG49 - QG74 - QG75 QG50 - QG51 - QG52 - QG53 - QG54 QG55 - QG56 - QG57 - QG76 - QG77	>0,95	0,127	
MT38 - MT39 - MT40 - MT41 - MT76	>0,9	0,089	
P232 - P233 - P234 - P235 - P247 QG66 - QG67 - QG68 - QG69 - QG70 QG71 - QG72 - QG73 - QG80 - QG81 QV28 - QV29 - QV30 - QV31 - QV32 QV33 - QV34 - QV35 - QV36 - QV37	>0,95	0,186	
P224 - P225 - P226 - P227 - P245	>0,95	0,147	
MT54 - MT55 - MT56 - MT57 - P246	>0,95	0,143	
MT62 - MT63 - MT64 - MT82	>0,9	0,156	
MT68 - MT69 - MT70 - P249	>0,95	0,212	
P252	>0,95	0,157	
N208	0,86	0,035	
P945	0,86	0,037	
N210	>0,9	0,065	
P946	>0,9	0,064	
N212	>0,95	0,099	
P947	>0,9	0,103	
MXJ0 - Q744	>0,95	0,105	
P251 - Q745	>0,95	0,104	
P203 - P204 - P205 - P206 - P211	>0,95	0,122	
P213 - P214 - P215 - P216 - P221	>0,95	0,083	
P217 - P218 - P219 - P220 - P222	>0,95	0,101	

1.154.598.14 IS10226/08	iGuzini	fattore di potenza - power factor - facteur de puissance Leistungsfaktor - vermogensfactor - factor de potencia effektfaktor - effektfaktor эффектфактор - фактор мощности - 功率因数	corrente assorbita - absorbed current - courant absorbé Stromaufnahme - stroomopname corriente absorbida - absorberet ström - absorberet ström tillförd ström - потребляемая мощность - 电源电流 (A)
ART.			
MJ67 - MJ68 - MJ71 - MJ72 - MR55 MR56 - MJ66 - MJ69 - MJ70 - MJ73	>0,95	0,1	
MJ74 - MJ75 - MJ76 - MJ77 - MR57 MT42 - MT43 - MT44 - MT45 - MT77	>0,9	0,091	
MJ86 - MJ87 - MJ88 - MJ89 - MR60 MT46 - MT47 - MT48 - MT49 - MT78	>0,9	0,104	
MJ78 - MJ79 - MJ80 - MJ81 - MR58	>0,9	0,086	
MJ82 - MJ83 - MJ84 - MJ85 - MR59	>0,9	0,093	
MJ98 - MJ99 - MK00 - MK01 - MR63 QG58 - QG59 - QG60 - QG61 - QG62 QG63 - QG64 - QG65 - QG78 - QG79 RC00 - RC01 - RC02 - RC03 - RC04 RC05 - RC06 - RC07 - RC08 - RC09	>0,95	0,18	
MJ90 - MJ91 - MJ92 - MJ93 - MR61	>0,95	0,135	
MJ94 - MJ95 - MJ96 - MJ97 - MR62	>0,9	0,15	
MK02 - MK03 - MK04 - MR64	>0,95	0,14	
MK05 - MK06 - MK07 - MK08 - MR65	>0,95	0,2	
MK09 - MK10 - MK11 - MK12 - MR66	>0,95	0,24	
P242 - P243 - P244 - P250 P236 - P237 - P238 - P248	>0,95	0,25	
MK13 - MK14 - MK15 - MK16	>0,95	0,4	
MK26 - MK27 - MK28 - MR69 MK18 - MK19 - MK20 - MR67	>0,95	0,256	
MK22 - MK23 - MK24 - MR68	>0,95	0,208	
MK29 - MK30 - MK31 - MR32 - MR70 ML53	>0,95	0,3	
MK33 - MK34 - MK35 - ML52	>0,95	0,45	
MR98	>0,95	0,142	
P626 - P627 - P628 - P629 - P634	>0,95	0,118	
P207 - P208 - P209 - P210 - P212 P630 - P631 - P632 - P633 - P635 QG42 - QG43 - QG44 - QG45 - QG46 QG47 - QG48 - QG49 - QG74 - QG75 QG50 - QG51 - QG52 - QG53 - QG54 QG55 - QG56 - QG57 - QG76 - QG77	>0,95	0,127	
MT38 - MT39 - MT40 - MT41 - MT76	>0,9	0,089	
P232 - P233 - P234 - P235 - P247 QG66 - QG67 - QG68 - QG69 - QG70 QG71 - QG72 - QG73 - QG80 - QG81 QV28 - QV29 - QV30 - QV31 - QV32 QV33 - QV34 - QV35 - QV36 - QV37	>0,95	0,186	
P224 - P225 - P226 - P227 - P245	>0,95	0,147	
MT54 - MT55 - MT56 - MT57 - P246	>0,95	0,143	
MT62 - MT63 - MT64 - MT82	>0,9	0,156	
MT68 - MT69 - MT70 - P249	>0,95	0,212	
P252	>0,95	0,157	
N208	0,86	0,035	
P945	0,86	0,037	
N210	>0,9	0,065	
P946	>0,9	0,064	
N212	>0,95	0,099	
P947	>0,9	0,103	
MXJ0 - Q744	>0,95	0,105	
P251 - Q745	>0,95	0,104	
P203 - P204 - P205 - P206 - P211	>0,95	0,122	
P213 - P214 - P215 - P216 - P221	>0,95	0,083	
P217 - P218 - P219 - P220 - P222	>0,95	0,101	

2.509.493.00
IS11580/00

iGuzzini

موضع تركيب المهايئ

POSIZIONE DI INSTALLAZIONE ADATTATORE
ADAPTER INSTALLATION POSITION
POSICIÓN DE INSTALACIÓN DEL ADAPTADOR

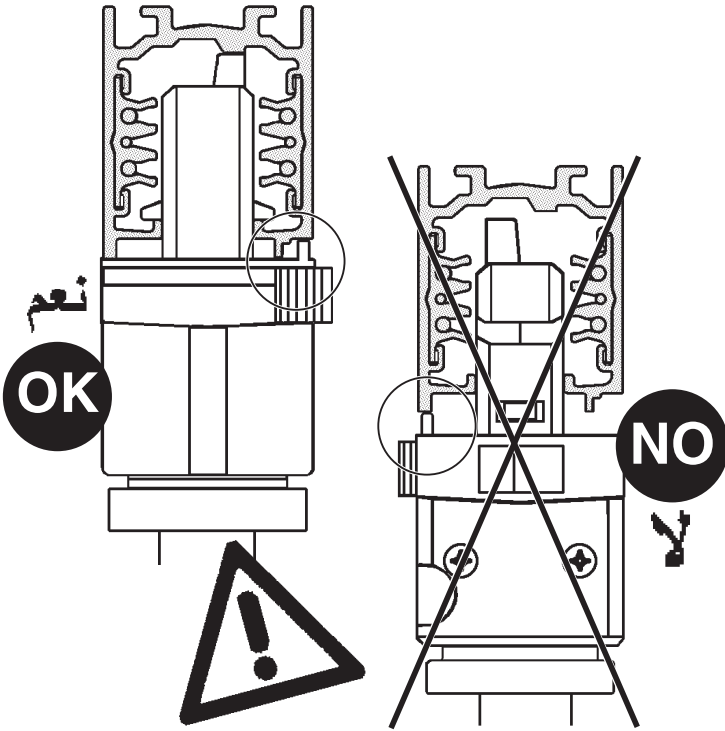

2.509.493.00
IS11580/00

iGuzzini

موضع تركيب المهايئ

POSIZIONE DI INSTALLAZIONE ADATTATORE
ADAPTER INSTALLATION POSITION
POSICIÓN DE INSTALACIÓN DEL ADAPTADOR

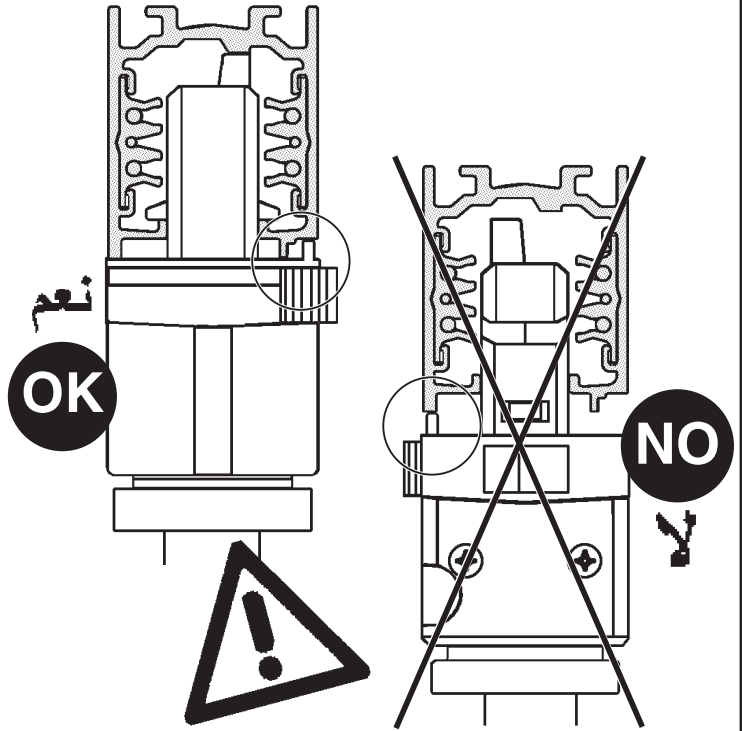

2.509.493.00
IS11580/00

iGuzzini

موضع تركيب المهايئ

POSIZIONE DI INSTALLAZIONE ADATTATORE
ADAPTER INSTALLATION POSITION
POSICIÓN DE INSTALACIÓN DEL ADAPTADOR

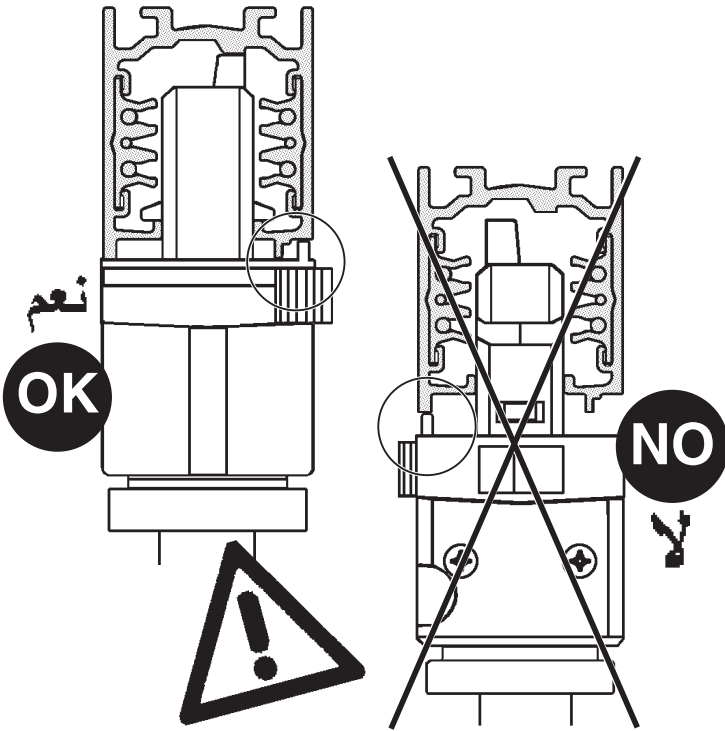

2.509.493.00
IS11580/00

iGuzzini

موضع تركيب المهايئ

POSIZIONE DI INSTALLAZIONE ADATTATORE
ADAPTER INSTALLATION POSITION
POSICIÓN DE INSTALACIÓN DEL ADAPTADOR

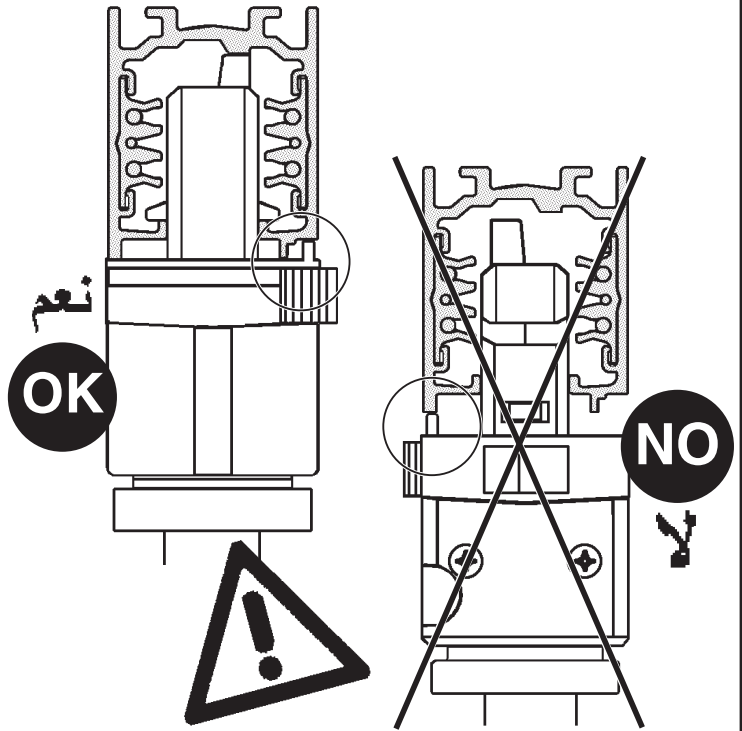

- I Istruzioni per le operazioni di servizio per l'apparecchio di illuminazione**
GB Instructions on luminaire service operations
F Instructions pour les opérations de service du luminaire
D Wartungsanleitung für die Leuchte
NL Instructies voor de onderhoudsoperaties op de verlichtingsarmatuur
E Instrucciones para las operaciones de servicio del aparato de alumbrado
DK Anvisninger i serviceindgreb på belysningsarmatur
N Anvisninger for betjening av lysapparatet
S Instruktioner för användning av belysningsanordningen
RUS Инструкции по эксплуатации осветительного прибора
CN 照明装置检修操作说明

Sostituire la lampada parzialmente esausta
 Replace the partly exhausted lamp
 Remplacer la lampe partiellement épuisée
 Die teilweise erschöpfte Lampe austauschen
 Vervang de gedeeltelijk lege lamp
 Sustituir la lámpara parzialmente agotada
 Udskift den delvist udtjente pære
 Skifte ut den delvis utbrænte lyspæren
 Byt ut den delvis förbrukade lampan
 Замена частично отработанной лампочки
 更换部分老化的灯泡



Spegnimento
 Switch it off
 Extinction
 Ausschaltung
 Uitschakeling
 Apagado
 Slukking
 Släckning
 Выключение
 关灯

Interrompere l'alimentazione dell'apparecchio
 Cut the power supply to the luminaire
 Couper l'alimentation du luminaire
 Stromversorgung der Leuchte unterbrechen
 Onderbreek de voeding van het apparaat
 Interrumpir la alimentación del aparato
 Afbryd armaturets strømforsyning
 Avbryte strømtilførselen til apparatet
 Koppla från anordningens strömförsörjning
 Отключить электропитание прибора
 中断装置供电



Aprire l'apparecchio
 Open the fixture
 Ouvrir le luminaire
 Das Gerät öffnen
 Open het apparaat
 Abrir el aparato
 Åbn armaturet
 Åpne apparatet
 Öppna anordningen
 Раскрыть прибор
 打开装置



Rimuovere la lampada esausta
 Remove the exhausted lamp
 Retirer la lampe épuisée
 Die alte Lampe entnehmen
 Verwijder de lege lamp
 Quitar la lámpara agotada
 Tag den udtjente pære ud
 Fjerne den utbrænte lyspæren
 Ta bort den förbrukade lampan
 Вынуть старую лампочку
 取出老化的灯泡

Portarla in un centro di riciclaggio
 Carry it to a recycling centre
 La porter dans une déchetterie pour son recyclage
 Ordnungsgemäß entsorgen
 Breng de lamp naar een recyclingcentrum
 Llevarla a un centro de reciclaje
 Aflever den på en genbrugsstation
 Lever den til en miljøstasjon
 Lämna in den till en återvinningsanläggning
 Сдать ее в пункт приема утильсырья
 将其送往回收中心



Inserire la nuova lampada
 Introduce the new lamp
 Installer la lampe neuve
 Die neue Lampe einsetzen
 Doe de nieuwe lamp op zijn plek
 Montar la nueva lámpara
 Sæt den nye pære i
 Sette i den nye pæren
 Sätt i den nya lampan
 Вставить новую лампочку
 装入新灯泡

Inserire la nuova lampada nel portalampana
 Fit the new lamp into the socket
 Installer la nouvelle lampe dans le support de lampe
 Die neue Lampe in den Sockel einsetzen
 Doe de nieuwe lamp in de lamphouder
 Montar la nueva lámpara en el portalampana
 Sæt den nye pære i fatningen
 Sette den nye pæren inn i lampeholderen
 Sätt i den nya lampan i lamphållaren
 Вставить новую лампочку в патрон
 将新灯泡插入灯泡架中



Riposizionare ottica
 Re-place the optic
 Remettre l'optique à sa place
 Die Optik wieder einsetzen
 Doe de optiek weer op zijn plaats
 Volver a montar la óptica
 Sæt den optiske enhed på plads
 Innstille linsen
 Flytta om optiken
 Отрегулировать линзы
 重新定位光头



Effettuare prova di funzionamento
 Perform operative test
 Procéder à un essai de fonctionnement
 Eine Funktionsprüfung durchführen
 Controleer de correcte werking
 Hacer una prueba de funcionamiento
 Afprøv funktionen
 Prové om den fungerer
 Utför funktionstest
 Выполнить проверку исправности работы
 执行功能测试



- I Istruzioni per la pulizia dell'apparecchio di illuminazione
 GB Instructions on luminaire cleaning operations
 F Instructions pour le nettoyage du luminaire
 D Anweisungen zur Reinigung der Leuchte
 NL Instructies voor de reiniging van de verlichtingsarmatuur
 E Instrucciones para limpiar el aparato de alumbrado
 DK Anvisninger i rengøring af belysningsarmaturet
 N Anvisninger for rengjøring av lysapparatet
 S Instruktioner för rengöring av belysningsanordningen
 RUS Инструкции по чистке осветительного прибора
 CN 照明装置清洁说明

Pulire l'apparecchio
 Clean the fixture
 Nettoyer le luminaire
 Das Gerät reinigen
 Reinig het apparaat
 Limpiar el aparato
 Rengør armaturet
 Rengjøre apparatet
 Rengör anordningen
 Чистка прибора
 清洁装置



Spegnimento
 Switch it off
 Extinction
 Ausschaltung
 Uitschakeling
 Apagado
 Slukning
 Slukking
 Släckning
 Выключение
 关灯

Interrompere l'alimentazione dell'apparecchio
 Cut the power supply to the luminaire
 Couper l'alimentation du luminaire
 Stromversorgung der Leuchte unterbrechen
 Onderbreek de voeding van het apparaat
 Interrumpir la alimentación del aparato
 Afbryd armaturets strømforsyning
 Avbryt strømtilførselen til apparatet
 Koppla från anordningens strömförsörjning
 Отключить электропитание прибора
 中断装置供电



Spolverare l'ottica esterna
 Remove dust from the external optic
 Dépoussiérer l'optique extérieure
 Die externe Optik abstauben
 Stof de externe optiek af
 Quitar el polvo de la óptica exterior
 Tør støvet af den udvendige optiske enhed
 Fjerne støv fra den eksterne lysenheden
 Damma av den yttre optiken
 Вытереть пыль с внешней стороны линз
 为外侧镜头掸尘



Lavare l'ottica esterna
 Wash the external optic
 Laver l'optique extérieure
 Die externe Optik waschen
 Was de externe optiek
 Lavar la óptica exterior
 Vask den udvendige optiske enhed
 Vaske den eksterne lysenheden
 Rengör den yttre optiken
 Вымыть линзы с внешней стороны
 清洁外镜头



Rimuovere l'ottica
 Remove the optic
 Retirer l'optique
 Die Optik abnehmen
 Verwijder de optiek
 Quitar la óptica
 Tag den optiske enhed af
 Fjerne lysenheden
 Ta bort optiken
 Снять линзы
 取下镜头



Pulire la parte interna dell'apparecchio di illuminazione
 Clean the inside of the fixture
 Nettoyer l'intérieur du luminaire
 Die Innenseite der Leuchte reinigen
 Reinig de binnenzijde van de verlichtingsarmatuur
 Limpiar el interior del aparato de alumbrado
 Rengør belysningsarmaturets indvendige dele
 Rengjøre lysapparatet innvendig
 Rengör belysningsanordningen invändigt
 Протереть осветительный прибор изнутри
 清洁照明装置内部



Riposizionare ottica
 Re-place the optic
 Remettre l'optique à sa place
 Die Optik wieder einsetzen
 Doe de optiek weer op zijn plaats
 Volver a montar la óptica
 Sæt den optiske enhed på plads
 Innstille linsen
 Flytta om optiken
 Отрегулировать линзы
 重新定位镜头



Effettuare prova di funzionamento
 Perform operative test
 Procéder à un essai de fonctionnement
 Eine Funktionsprüfung durchführen
 Controleer de correcte werking
 Hacer una prueba de funcionamiento
 Afprøv funktionen
 Prøve om den fungerer
 Utför funktionstest
 Выполнить проверку исправности работы
 执行功能测试



- I Istruzioni per il fine vita e lo smaltimento dei componenti**
GB Instructions on end-of-life and component disposal
F Instructions pour la gestion des composants en fin de vie et leur mise au rebut
D Anweisungen zur Entsorgung der Leuchtenkomponenten
NL Instructies voor het verwijderen van de armatuur en het recyclen van de onderdelen
E Instrucciones para el final de vida y la eliminación los componentes
DK Anvisninger i udtjent armatur og bortskaffelse af komponenter
N Anvisninger for endt levetid og avfallsbehandling av delene
S Instruktionser vid bortskaffning och kassering av komponenter
RUS Инструкции по утилизации прибора и его комплектующих по окончании его срока службы
CN 寿命期结束与零件废弃处置说明

Spegnimento
Switch it off
Extinction
Ausschaltung
Uitschakeling
Apagado
Slukning
Slukking
Släckning
Выключение
关灯

Interrompere l'alimentazione dell'apparecchio
Cut the power supply to the luminaire
Couper l'alimentation du luminaire
Stromversorgung der Leuchte unterbrechen
Onderbreek de voeding van het apparaat
Interrompirla alimentación del aparato
Afbryd armaturets strømforsyning
Avbryt strømtilførselen til apparatet
Koppla från anordningens strömförsörjning
Отключить электропитание прибора
中断装置供电



Rimuovere la/e lampada/e per la dismissione
Remove the lamp(s) for decommissioning
Retirer la(les) lampe(s) pour sa(leur) mise au rebut
Die Lampe/n ordnungsgemäß entsorgen
Verwijder de lamp(en) voor het recyclen
Quitar la(s) lámpara(s) para el desecho
Tag pæren/pærerne ud til bortskaffelse
Fjerne lampen/-e som skal kastes
Ta bort lampan/-orna för bortskaffningen
Вынуть лампочку/и для утилизации прибора
取出需要丢弃的灯泡

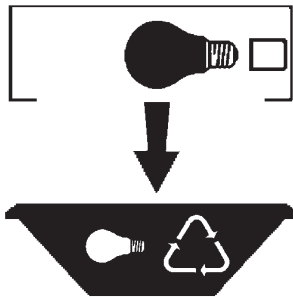

Rimuovere la batteria per la dismissione
Remove the battery for decommissioning
Retirer la batterie pour sa mise au rebut
Die Batterie ordnungsgemäß entsorgen
Verwijder de batterij voor het recyclen
Quitar la batería para el desecho
Tag batteriet ud til bortskaffelse
Fjerne batteriet som skal kastes
Ta bort batteriet för bortskaffningen
Вынуть батарейку для утилизации прибора
取出需要丢弃的电池



Rimuovere l'apparecchio per la dismissione
Remove the fixture for decommissioning
Enlever le luminaire pour sa mise au rebut
Das Gerät ordnungsgemäß entsorgen
Verwijder het apparaat voor het recyclen
Quitar el aparato para el desecho
Tag armaturet ud til bortskaffelse
Fjerne apparatet som skal kastes
Ta bort anordningen för bortskaffningen
Снять прибор для утилизации
取出需要丢弃的装置

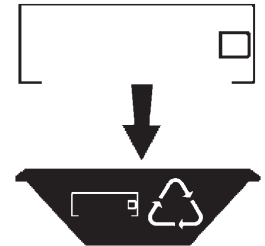

Inviare i materiali ad un centro di raccolta
RAEE
Send the materials to a WEEE collection
centre
Envoyer les matériaux dans une déchetterie
DEEE
Die Materialien in einem WEEE-Zentrum
entsorgen
Zend de materialen naar een recyclingscentrum
voor de AEEA
Enviar los materiales a un centro de recogida
RAEE
Afløver materialerne på et indsamlingscenter
for elektronisk udstyr
Sende materialene til en miljøstasjon for
resirkulering av EE-avfall
Skicka materialet till en RAEE uppsamlingscentral
Сдать материалы в пункт приема утильсырья
将材料送往电气和电子垃圾回收中心

