

## BRACCI ORIZZONTALI

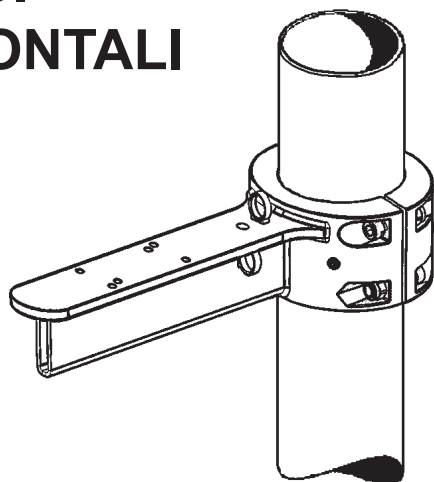

### APPLICATION:

AGORA' slim	AGORA' compact	MAXIWOODY	IPRO	PALCO IN-OUT	LINGOTTO WITH BASE	PLATEA PRO
X728 X811 +art. X458 X549 X550						
X729 X812 +art. X551 X552 X553						
Ø204 Ø254 Ø313 Ø368 Ø516	Ø254 Ø313 Ø368 Ø516 Ø516(COB)	Ø 315 Ø 260 (compact)	□ 192	Ø 83 (class II) Ø 119 Ø 137 Ø 153 Ø 116 (FRAMER) Ø 153 (FRAMER)		(a x b) 214 x 296 276 x 406

#### IT **Attenzione:**

La sicurezza dell'apparecchio e' garantita solo con l'uso appropriato delle seguenti istruzioni; pertanto e' necessario conservarle.

#### EN **Warning:**

The safety of this fixture is guaranteed only if you comply with these instructions; remember to conserve in a safe place.

#### FR **Attention:**

La sécurité de l'appareil n'est garantie qu'en cas d'utilisation correcte des instructions suivantes; il faut par conséquent les conserver.

#### DE **Achtung:**

Die sicherheit des gerätes wird nur durch sachgemässe befolgung nachstehender anweisungen gewährleistet; ihre aufbewahrung ist deshalb sehr wichtig.

#### NL **Opgelet:**

De veiligheid van di atoestel is slechts dan gegarandeerd als indien de volgende instructies strikt worden toegepast: daarom moet men ze ook bewaren.

#### ES **Atencion:**

La seguridad del aparato se garantiza solo cumpliendo cuidadosamente las siguientes instrucciones; por ello, es necesario conservarlas.

#### DA **Bemærk:**

Sikkerheden ved brug af armaturet kan kun garanteres, hvis disse anvisninger følges; sørg derfor for at gemme dem.

#### NO **Advarsel:**

Sikkerheten til dette apparatet garanteres kun hvis du overholder disse instruksjonene; husk å oppbevare dem på et trygt sted.

#### SV **Observera:**

Utrustningens säkerhet kan endast garanteras om dessa anvisningar respekteras i detalj. Spara därför dessa anvisningar för framtida konsultation.

#### RU **Внимание:**

Мы гарантируем безопасную эксплуатацию изделия только при соблюдении следующих инструкций; с этой целью необходимо сохранить данную брошюру.

#### ZH **警告:**

为确保该装置安全, 请遵守操作指示; 并于安全场所放置。

#### AR

تحذير: لا يمكن ضمان سلامة هذا الجهاز إلا إذا التزمت بهذه التعليمات. يجب حفظها في مكان آمن.

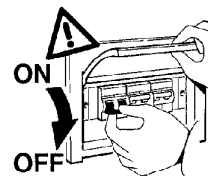

IT N.B.: Durante l'installazione del sistema rispettare scrupolosamente le norme impiantistiche vigenti.

EN N.B.: When installing the system, strictly comply with all regulations on installation in force.

FR N.B.: Lors de l'installation du système veuillez respecter rigoureusement les normes en vigueur en la matière.

DE N.B.: Beachten sie bei der installation des systems gewissenhaft die gültigen bestimmungen bezüglich der anlagentechnik.

NL N.B.: Bij het installeren van het systeem moet u de gelden de installatienormen strikt naleven.

ES N.B.: Durante la instalación del sistema respetar e scrupolosamente las normas de instalación vigentes.

DA N.B.: Under installation af systemet skal man nøje overholde de gældende regler for disse anlæg.

NO N.B.: Ved installasjon av systemet skal alle forskrifter om installasjon som gjelder følges strengt.

SV OBS.: Under installationen av systemet ska installationsföreskrifterna respekteras i detalj.

RU примечание: в процессе монтажа системы строго соблюдайте национальные действующие нормативы по электропроводке.

ZH 注意: 在安装系统时请遵守设备的安装规定。

AR ملاحظة: أثناء تركيب النظام يجب التقيد بحرص بالنظم السائدة المتطابقة بالشبكة الكهربائية.

IT DIMENSIONI, PESO E SUPERFICIE DI MASSIMO INGOMBRO, DELLA COMPOSIZIONE COMPLETA DI ACCESSORI.

EN MAXIMUM SIZE, WEIGHT AND AREA OF THE COMPOSITION COMPLETE WITH AND ACCESSORIES.

FR DIMENSIONS, POIDS ET SURFACE MAXIMUM D'ENCOMBREMENT DE LA COMPOSITION AVEC ACCESSOIRES.

DE ABMESSUNGEN, GEWICHT UND GRÖßTE FLÄCHE FÜR DIE KOMPLETT MIT ZUBEHÖR KOMPOSITION.

NL MAXIMUM AFMETINGEN, GEWICHT EN OPPERVLAKTE VAN DE COMPOSITIE, COMPLETE MET ACCESSOIRES.

ES DIMENSIONES, PESO Y SUPERFICIE MAXIMA DE OCUPACION, DEL CNJUNTO EQUIPADO CON ACCESORIOS.

DA MAKS. MÅL, VÆGT OG OVERFLADE AF DEN SAMLEDE INSTALLATION INKL. TILBEHØR.

NO MAKSIMAL STØRRELSE, VEKT OG OMRÅDE PÅ SAMMENSETNINGEN MED TILBEHØR.

SV MÅTT, VIKT OCH MAX. YTTRE MÅTT FÖR UTFÖRANDET FÖRSETT MED TILLBEHÖR.







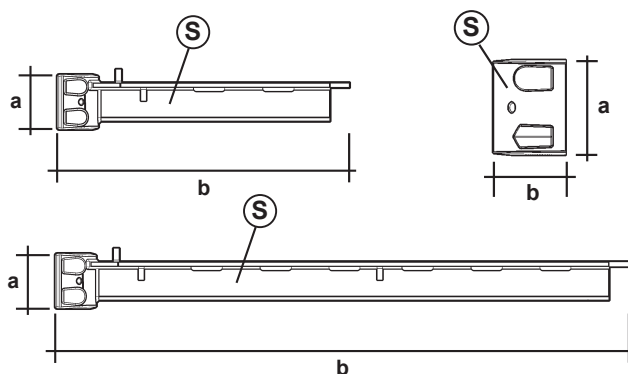

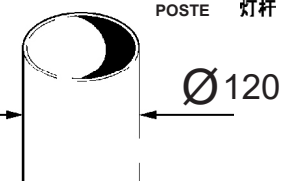
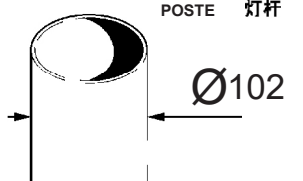

RU РАЗМЕРЫ, ВЕС И МАКСИМАЛЬНАЯ ЗАНИМАЕМАЯ ПЛОЩАДЬ КОНСТРУКЦИИ, УКОМПЛЕКТОВАННОЙ ВСПОМОГАТЕЛЬНЫМ УСТРОЙСТВОМ.

ZH 合成物最大尺寸、重量和面积, 包括附件

AR أقصى حجم ووزن ووسطح للتركيب بالملحقات

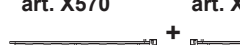

ART.	POLE	WEIGHT	Dimensions	Surface	
	Ø	(Kg)	a x b (mm)	S (mq)	
	X568	102	5,04	90 x 488	0,031
	X569	120	5,28	90 x 498	0,032
	X570	102	8,23	90 x 946	0,060
	X571	120	8,47	90 x 955	0,061
	6161	102	2,16	90 x 68	0,006
	6162	120	2,38	90 x 78	0,007

<p>PALO MAST POLE STANG MAT STANG MAST ФОНАРНЫЙ PAAL Столб POSTE 灯杆</p>  <p>Ø120</p>	<p>PALO MAST POLE STANG MAT STANG MAST ФОНАРНЫЙ PAAL Столб POSTE 灯杆</p>  <p>Ø102</p>
<p>art. 6162 + art. X569</p> 	<p>art. 6161 + art. X568</p> 
<p>art. 6162 + art. X571</p> 	<p>art. 6161 + art. X570</p> 
<p>art. X569 + art. X569</p> 	<p>art. X568 + art. X568</p> 
<p>art. X571 + art. X571</p> 	<p>art. X570 + art. X570</p> 
<p>art. X571 + art. X569</p> 	<p>art. X570 + art. X568</p> 

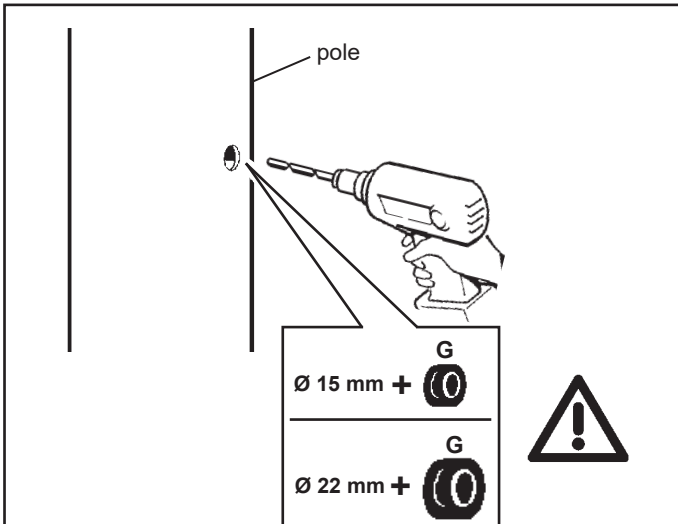

IT fare riferimento al foglio istruzioni CE dei pali.

EN please refer to the CE instruction sheet for the poles.

FR consulter la notice d'instructions CE sur les mâts.

DE CE-Unterweisungsblatt für Masten Bezug.

NL dient u het CE instructieblad van de palen te raadplegen.

ES hágase referencia a la hoja de instrucciones CE de los postes.

DA henvises til masternes EF-instruktionsblad.

NO se anvisningsarket CE til stengene

SV hänvisas till CE-instruktionsbladet för stolparna

RU см. инструкцию CE к полюсам

ZH 請參閱極點的 CE 說明書

AR راجع ورقة تعليمات CE للأعمدة

IT Nelle installazioni delle composizioni con il maggior numero di prodotti (N° max), in alcuni casi (Per la serie MULTIAGORA', MULTIPRO, MULTIWOODY fare riferimento al foglio istruzioni CE dei pali) occorre praticare sui pali i fori mancanti ed applicare i gommini "G" inclusi nell'imballo

EN When installing the compositions with the greatest number of products (max number), in some cases (For the MULTIAGORA', MULTIPRO, MULTIWOODY range, please refer to the CE instruction sheet for the poles) you need to drill holes into the poles and to apply the rubber elements "G" supplied in the package.

FR CPour l'installation de compositions montant le plus grand nombre possible de produits (N° maxi.), il faut dans certains cas (Pour la série MULTIAGORA', MULTIPRO, MULTIWOODY, consulter la notice d'instructions CE sur les mâts) percer sur les mâts les trous manquants et monter les caoutchoucs "G" fournis dans l'emballage.

DE Bei der Installation von Zusammenstellungen mit der größten Leuchtenzahl (max. Zahl) sind in einigen Fällen (Nehmen Sie für die Serie MULTIAGORA', MULTIPRO, MULTIWOODY auf das CE-Unterweisungsblatt für Masten Bezug) die fehlenden Löcher an den Masten vorzusehen und die in der Verpackung enthaltenen Gummiteilchen "G" anzubringen.

NL Bij het installeren van de samenstellingen met het grootste aantal producten (max ... ) moeten in enkele gevallen (Voor de serie MULTIAGORA', MULTIPRO, MULTIWOODY dient u het CE instructieblad van de palen te raadplegen ) de

mankerende gaten worden geboord en de bijgeleverde rubber sluitringen "G" worden aangebracht.

ES En las instalaciones de las composiciones con el máximo número de productos (N. máx), en algunos casos (Para la serie MULTIAGORA', MULTIPRO, MULTIWOODY hágase referencia a la hoja de instrucciones CE de los postes ) se necesita realizar las perforaciones que faltan en los postes y aplicar las gomas "G" incluidas en el embalaje.

DA I sammensatte installationer med flere produkter (maks.) skal man i nogle tilfælde (I serien MULTIAGORA', MULTIPRO, MULTIWOODY henvises til masternes EF-instruktionsblad) bore de manglende huller i masterne og sætte de medfølgende gummidelle "G" på.

NO Ved installasjon av sammenstillingene med størst antall produkter (maks. antall), må du i noen tilfeller (For serien MULTIAGORA', MULTIPRO, MULTIWOODY se anvisningsarket CE til stengene ) drille hull i stengene og bruke gummielementene "G" som medfølger i pakningen.

SV För installationer med ett större antal produkter (max. antal), är det ibland (För serien MULTIAGORA', MULTIPRO, MULTIWOODY hänvisas till CE-instruktionsbladet för stolparna ) nödvändigt att göra hål i de återstående stolparna och fästa gummipluggarna G som ingår i förpackningen.

RU При монтаже конструкций, включающих в себя большое количество осветительных приборов (макс. кол-во), в некоторых случаях (для серий MULTIAGORA', MULTIPRO, MULTIWOODY см. инструкцию CE для колонн) необходимо просверлить в стойках недостающие отверстия и вставить резиновые муфты «G», входящие в комплект.

ZH 安装有多个配件 (对于 MULTIAGORA', MULTIPRO, MULTIWOODY 系列, 请参阅立柱的 CE 说明书) 的产品可能需要 在杆打洞和使用 G 橡胶塞。

AR في تركيبات المكونات بأكبر عدد من المنتجات (أقصى عدد) في بعض الحالات (بالنسبة لسلسلة MULTIAGORA', MULTIPRO, MULTIWOODY راجع ورقة تعليمات CE للأعمدة) من الضروري حفر الثقوب المفقودة على الأعمدة ووضع المطاط "G" المتضمن في العبوة

IT Sfondare la membrana soltanto sui fori utilizzati per il passaggio dei cavi.

EN Break the membrane only on the holes used for passing through the cables.

FR Ne défoncer que la membrane des trous utilisés pour le passage des câbles

DE Die Membran nur an den für den Kabeldurchgang verwendeten Löchern durchstoßen.

NL Prik het membraan slechts door op de gaten voor het doorlaten van de kabels.

ES Rasgar la membrana únicamente en el lugar donde han de pasar los cables.

DA Membranen må kun gennembrydes ved de huller, der skal anvendes til kabelføring.

NO Lag hull på hinnene bare ved hullene som brukes for passering av kablene.

SV Krossa endast membranet vid hålen som används för kabelföringen.

RU Продавить мембрану только в точках, используемых для пропускания проводов

ZH 只在于通过电缆的孔处穿破薄膜。

AR يتم اختراق الغشاء فقط من خلال الفتحات المستخدمة لممرور الكابلات.

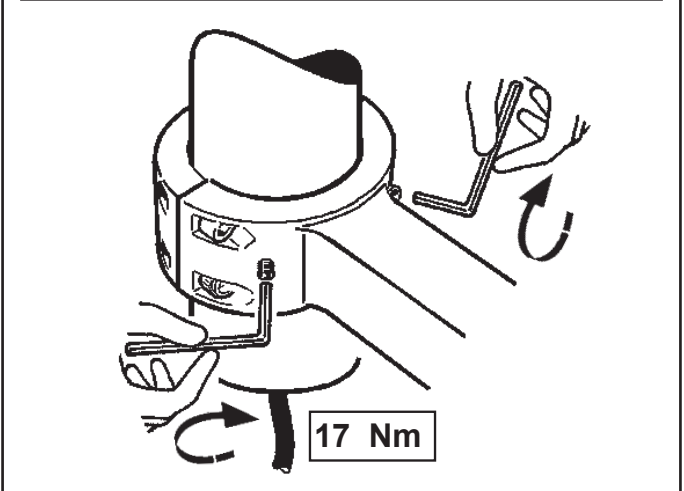
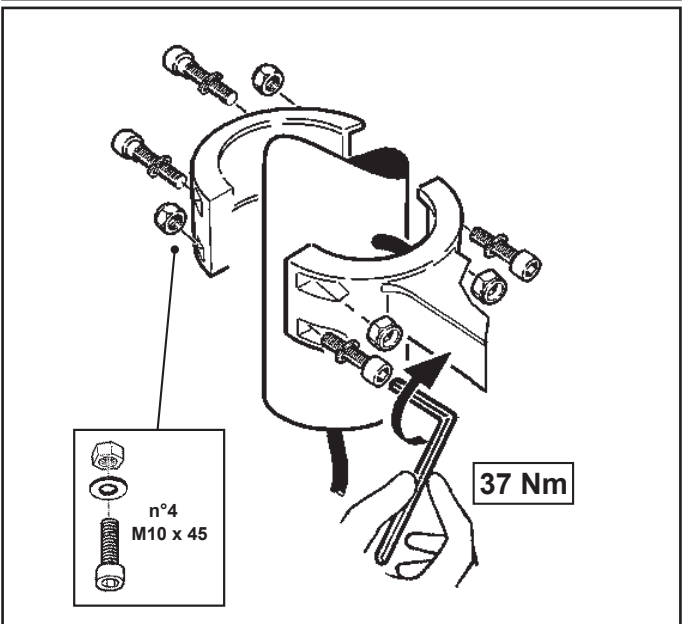

# AGORA' slim:

## CONFIGURATIONS INSTALLATIONS ALLOWED

### AGORA' slim $\varnothing 204$ - $\varnothing 254$ - $\varnothing 313$

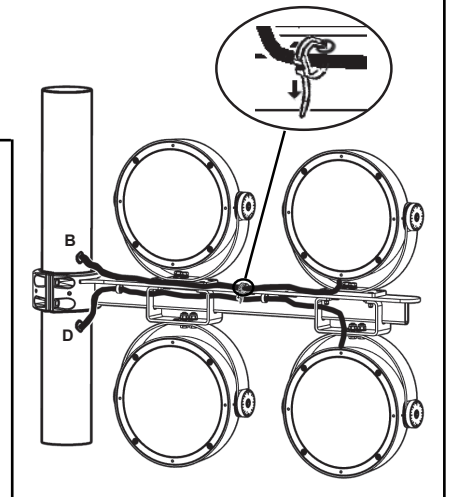
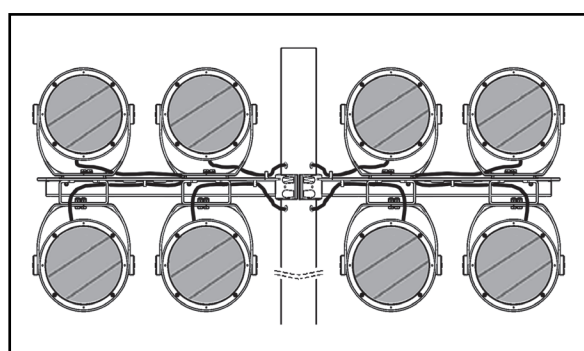
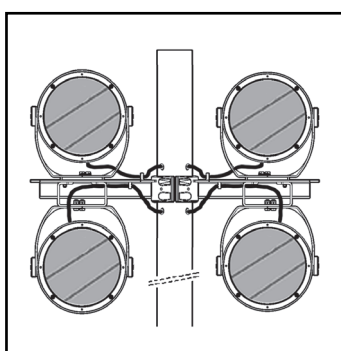
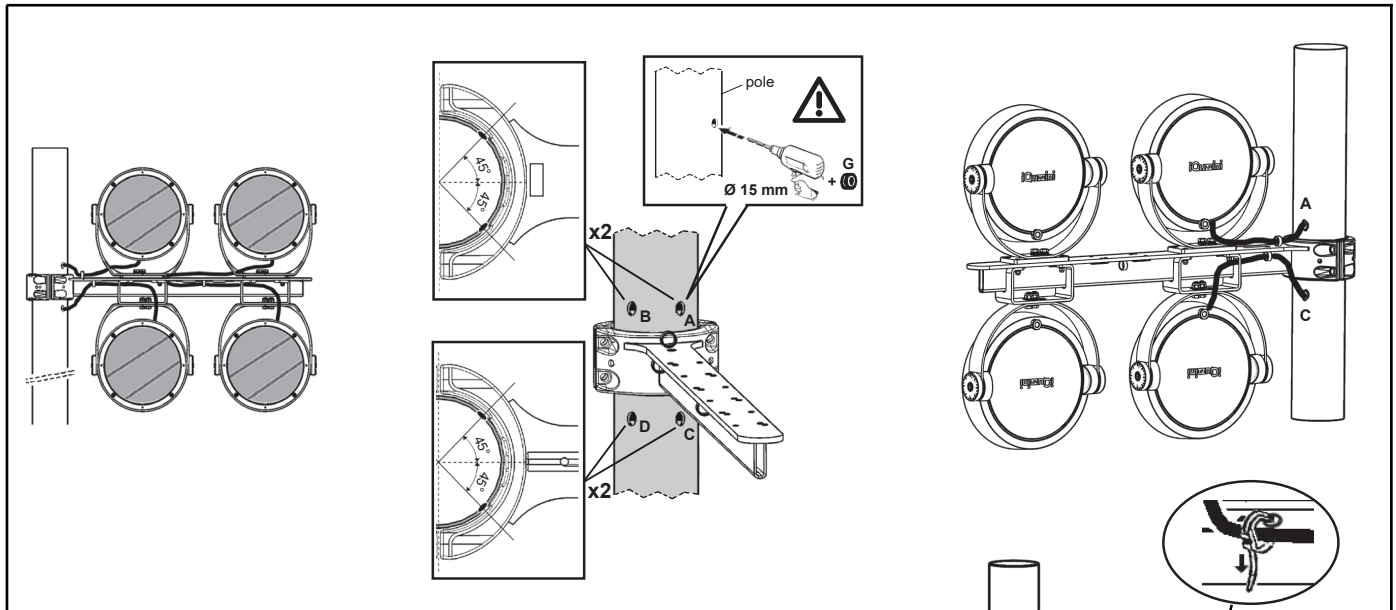
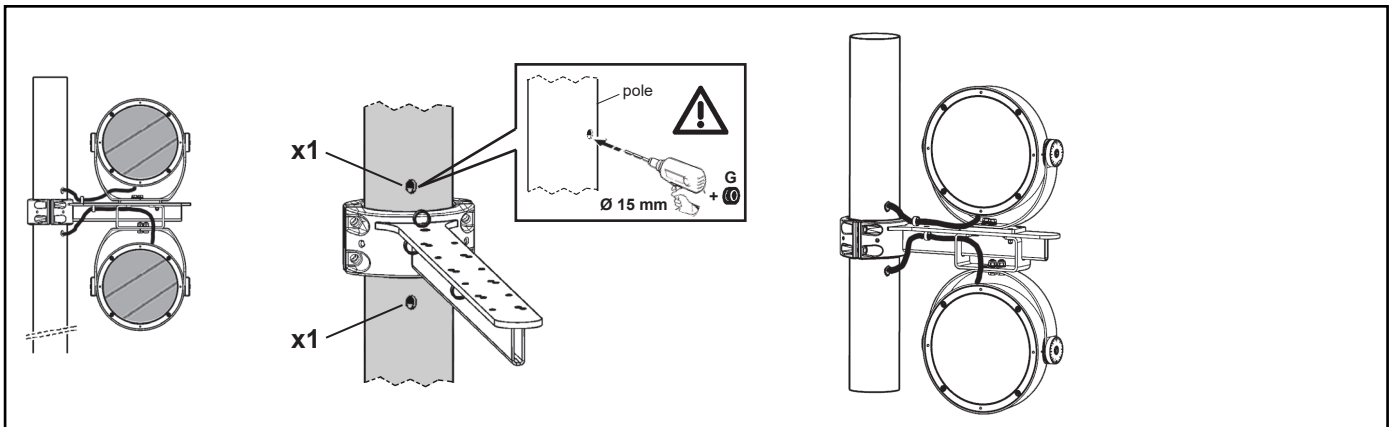
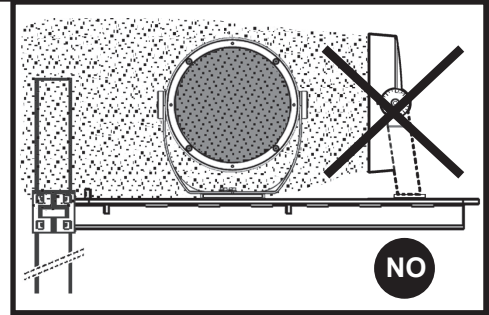

## AGORA' slim ø368

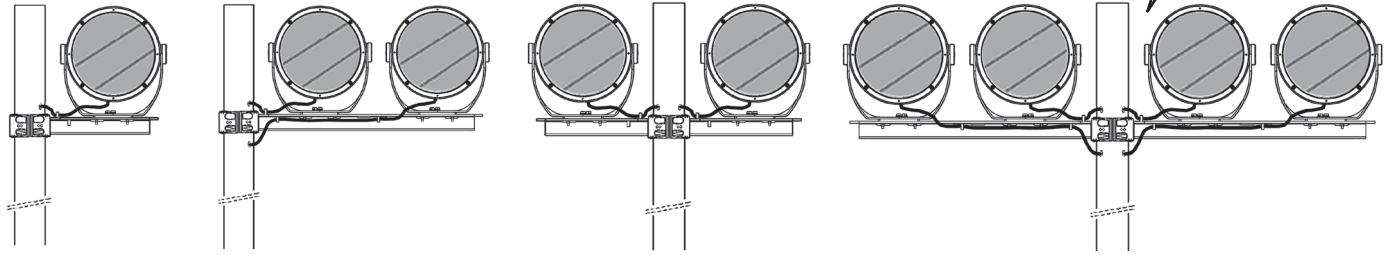
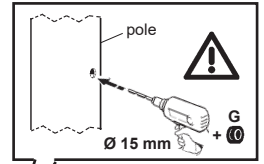

## AGORA' slim ø516

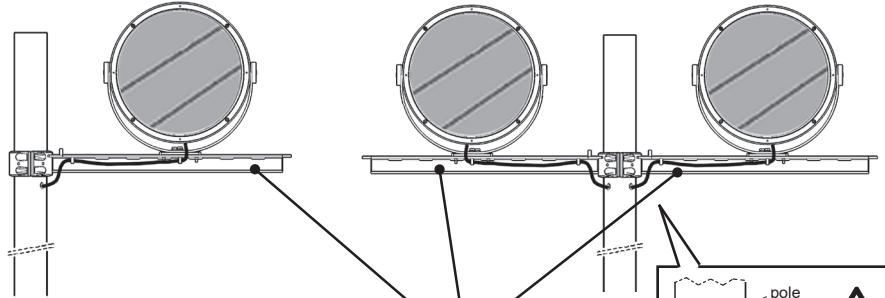

ONLY ART. X570 - X571

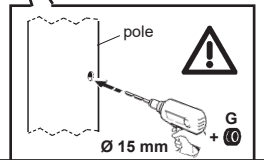

## AGORA' slim ø516

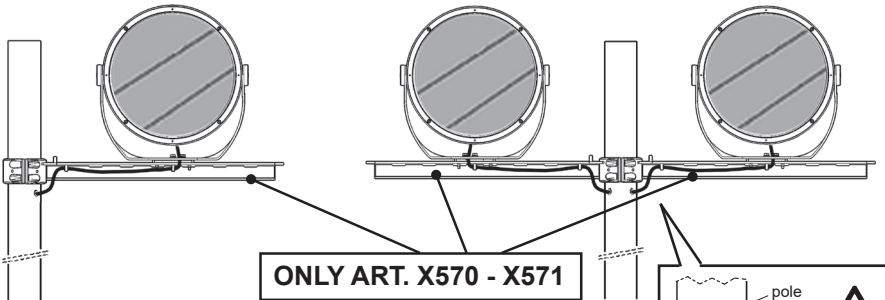

ONLY ART. X570 - X571

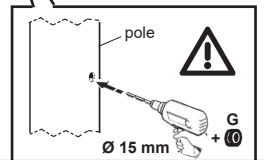

## AGORA' slim ø204 - ø254 - ø313 - ø368

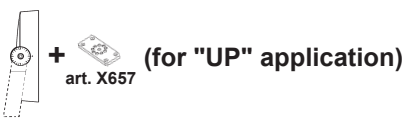

## AGORA' slim ø516

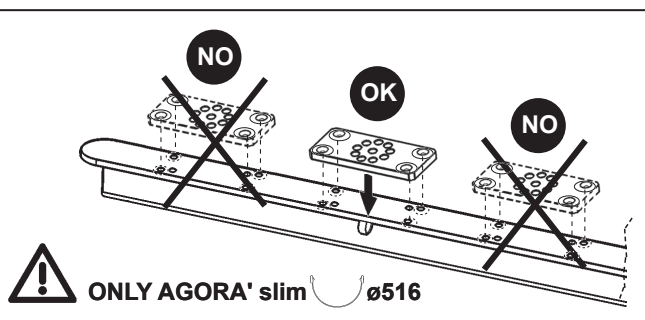
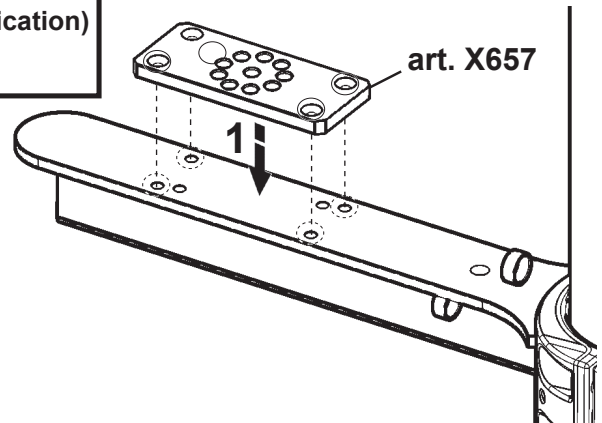

# AGORA' slim $\cup$ $\varnothing$ 516

+  (for "UP" application)  
art. X658

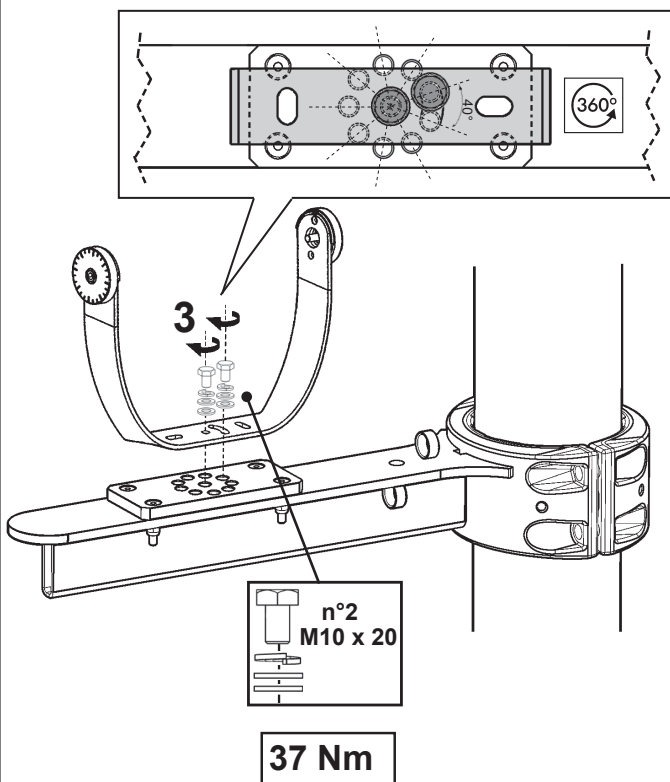
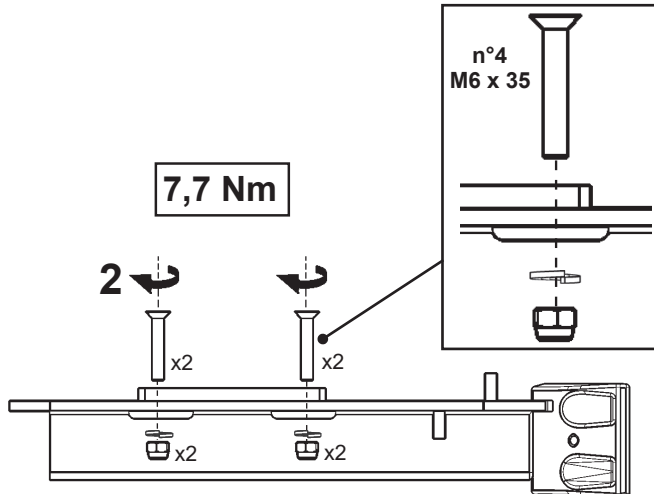
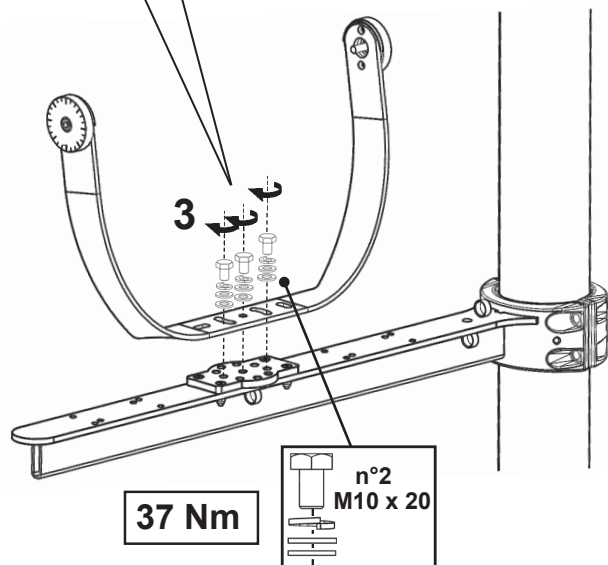
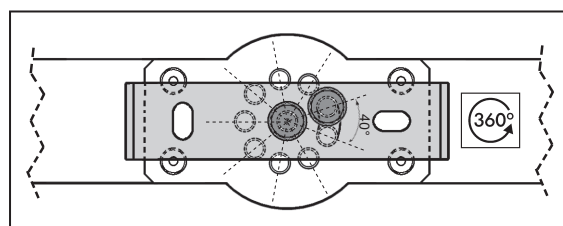
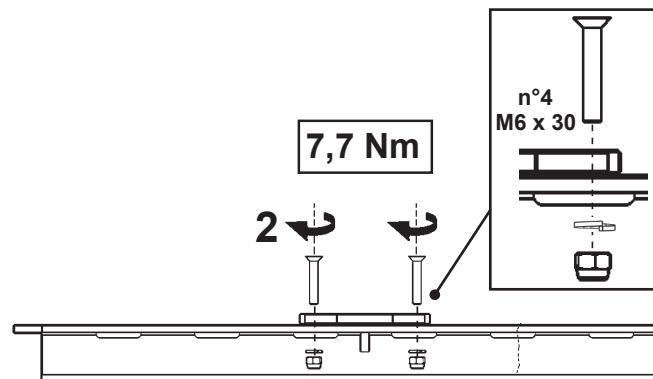
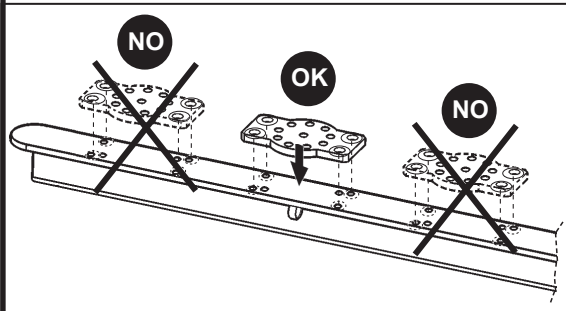
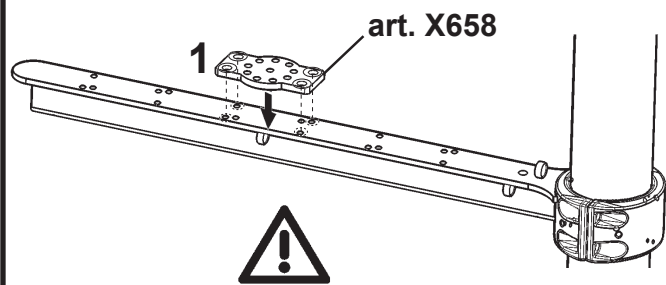

# AGORA' slim ø204 - ø254 - ø313

+  (for "DOWN" application)  
art. X572

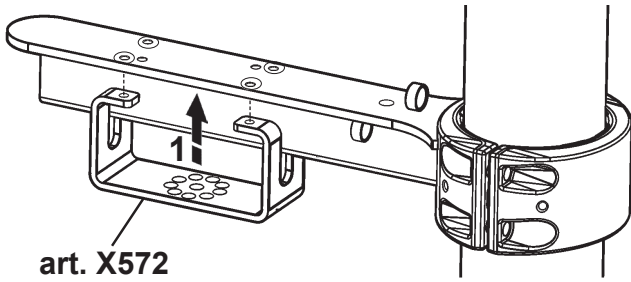

# AGORA' slim ø204 - ø254 - ø313

+  +  (for "UP/DOWN" application)  
art. X657 art. X572

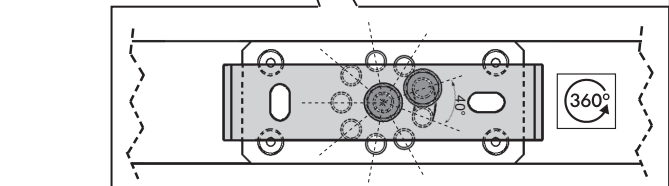
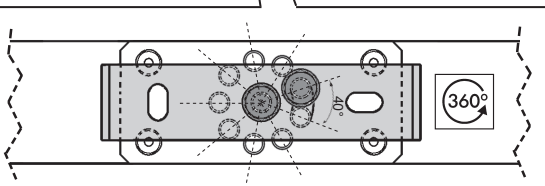
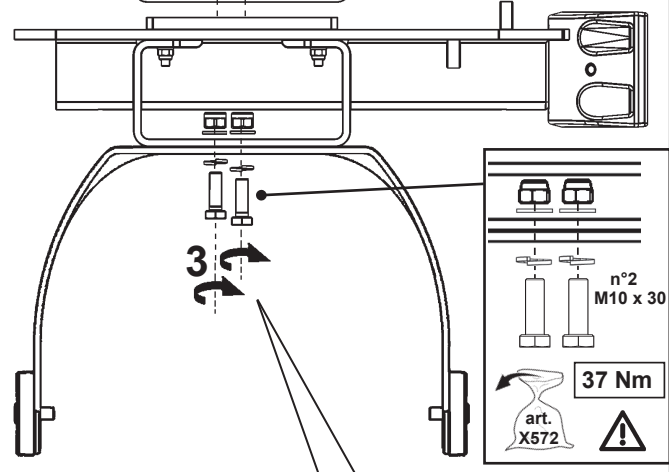
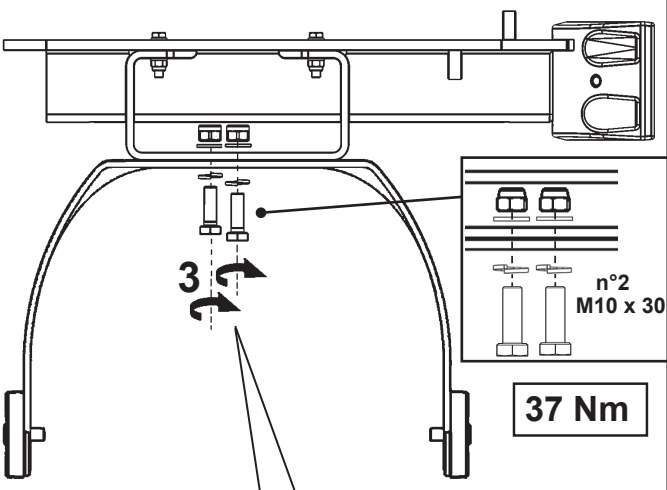
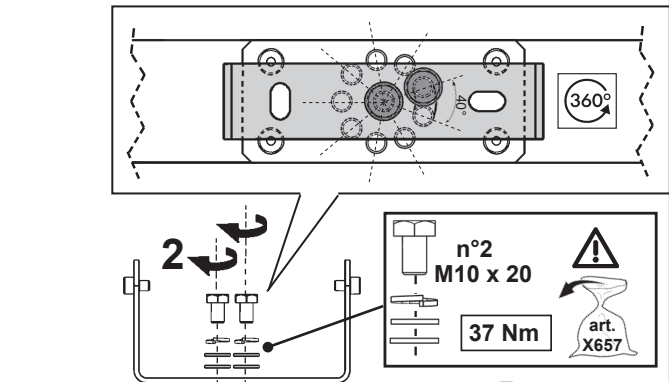
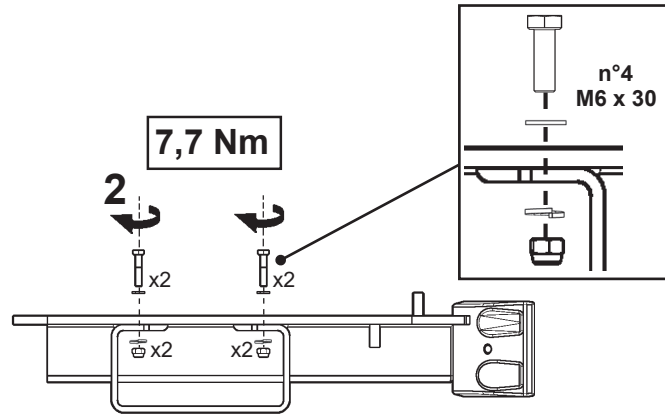
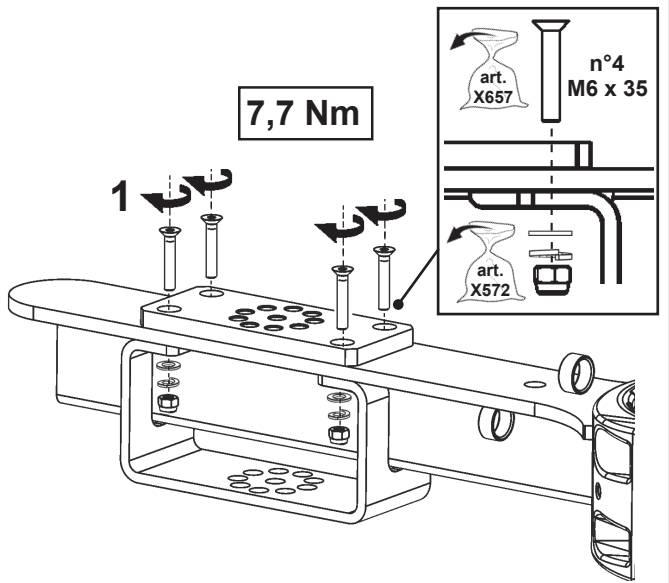

# AGORA' compact:

## CONFIGURATIONS INSTALLATIONS ALLOWED



### AGORA' compact $\varnothing 254 - \varnothing 313$

 +  (for "UP" application)  
art. X657

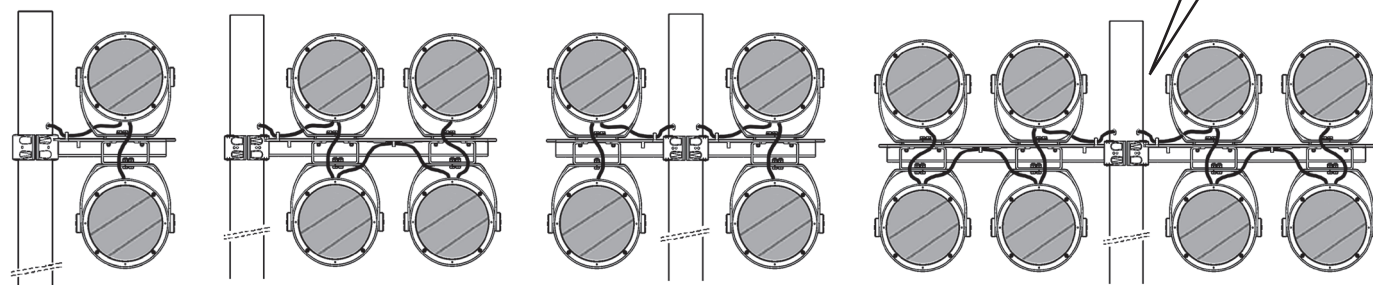
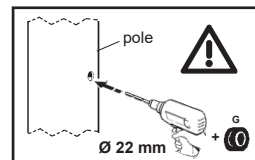
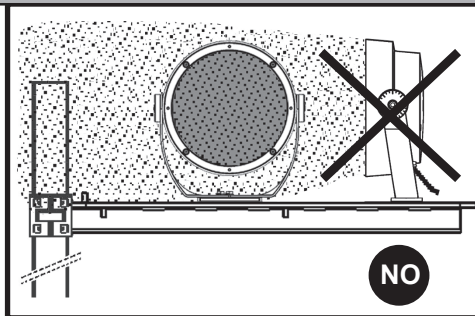
 +  (for "DOWN" application)  
art. X572

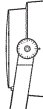

### AGORA' compact $\varnothing 368$

 +  (for "UP" application)  
art. X657

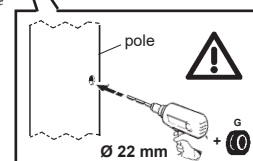
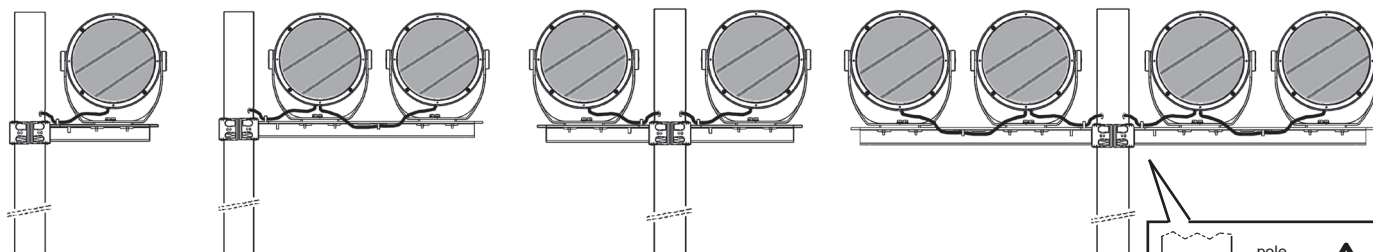

### AGORA' compact $\varnothing 516$

 +  (for "UP" application)  
art. X658

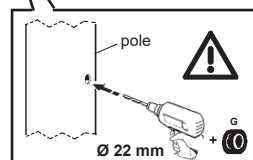
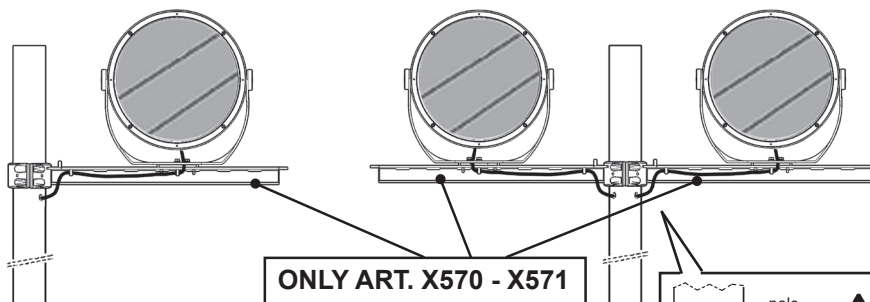



# AGORA' compact ø254 - ø313 - ø368

+ art. X657 (for "UP" application)

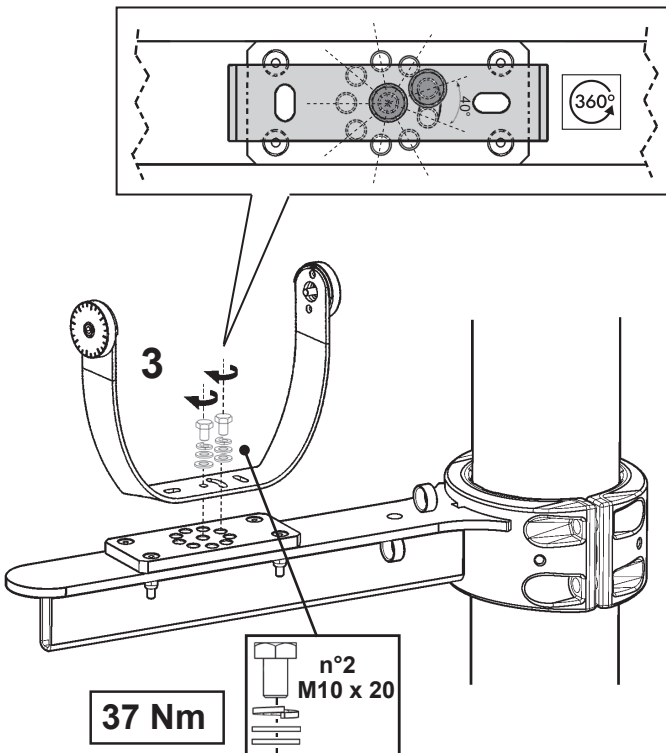
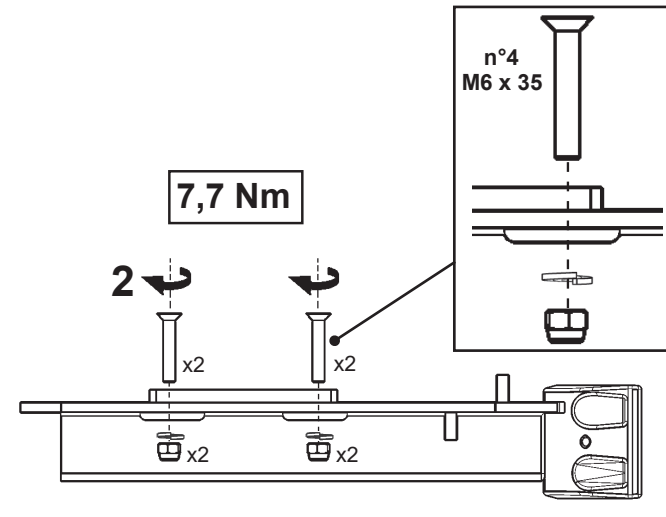
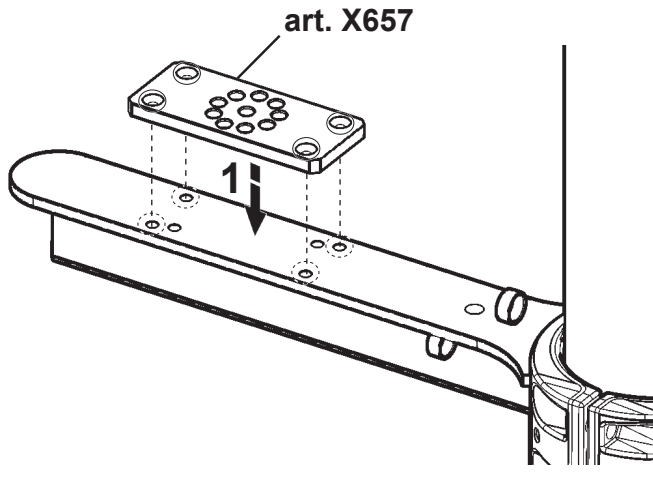

# AGORA' compact ø516

+ art. X658 (for "UP" application)

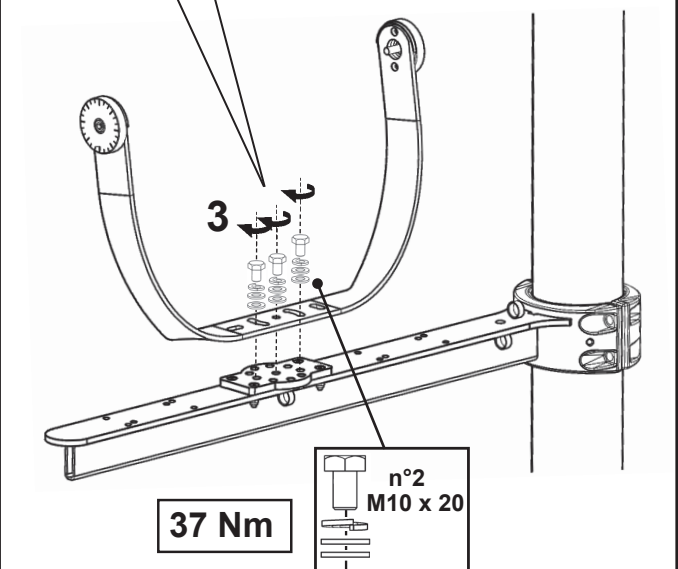
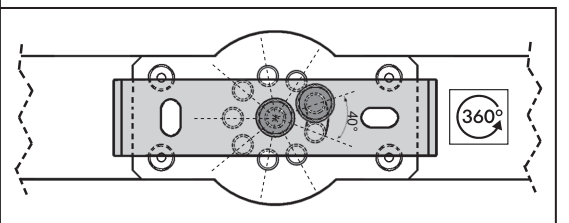
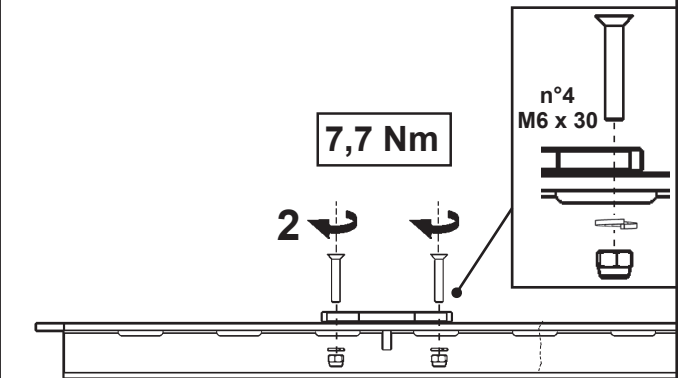
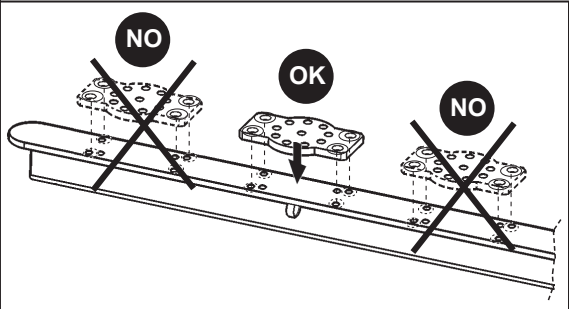
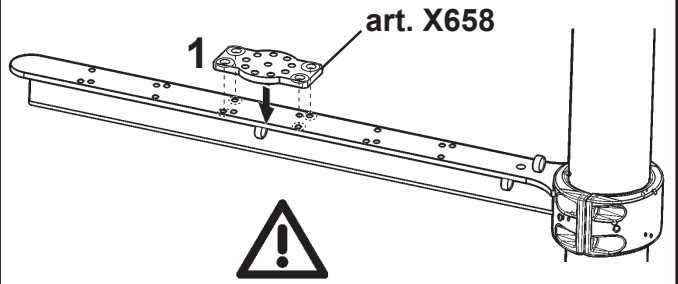



# AGORA' compact ø254 - ø313

 + **(for "DOWN" application)**  
art. X572

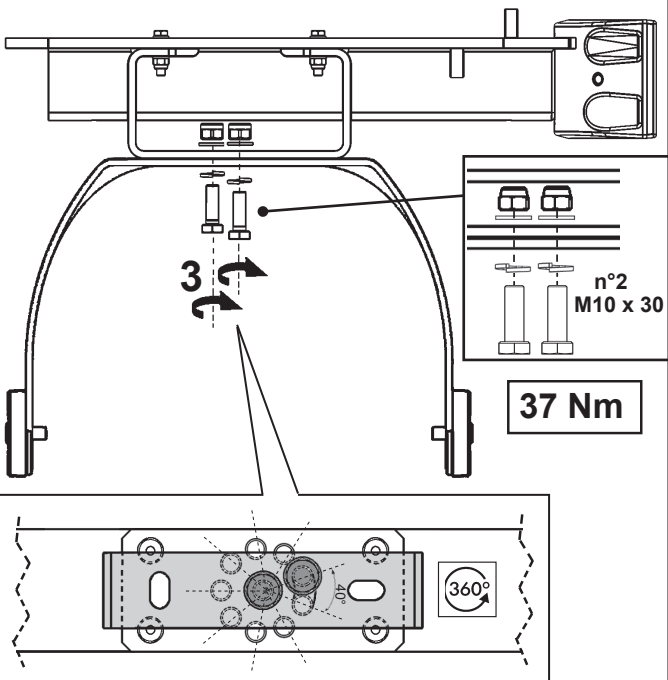
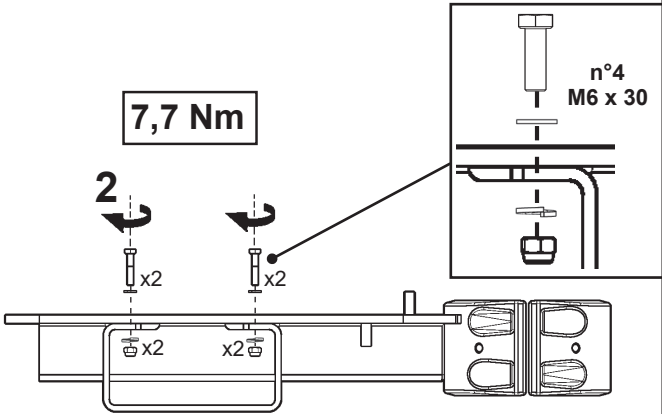
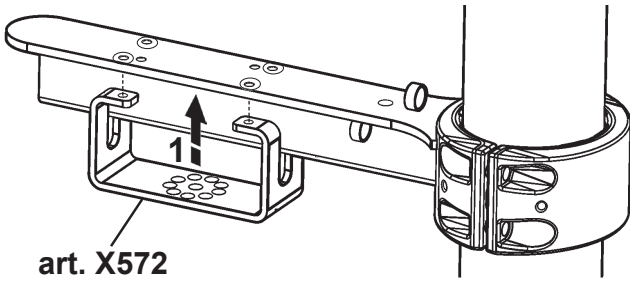

# AGORA' compact ø254 - ø313

 + **(for "UP/DOWN" application)**  
art. X657 art. X572

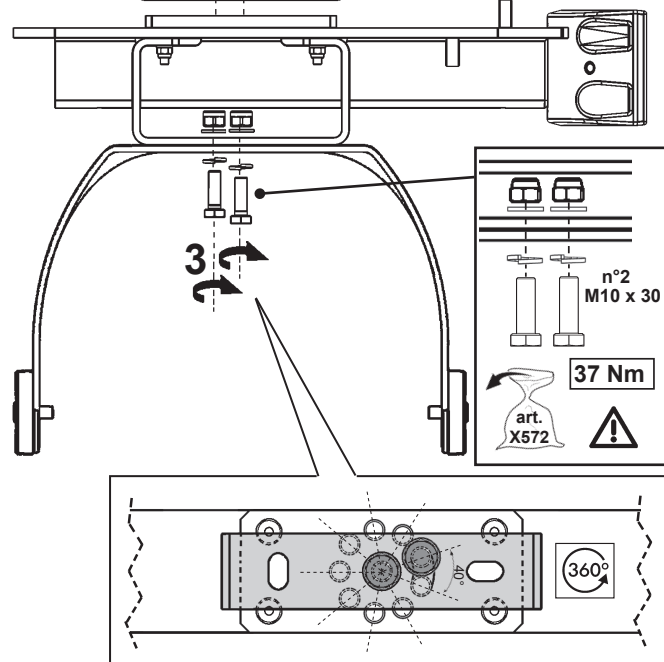
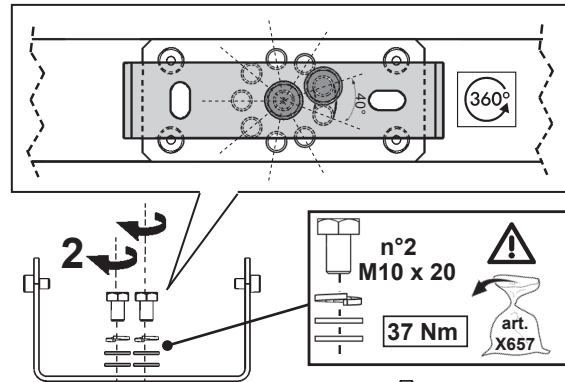
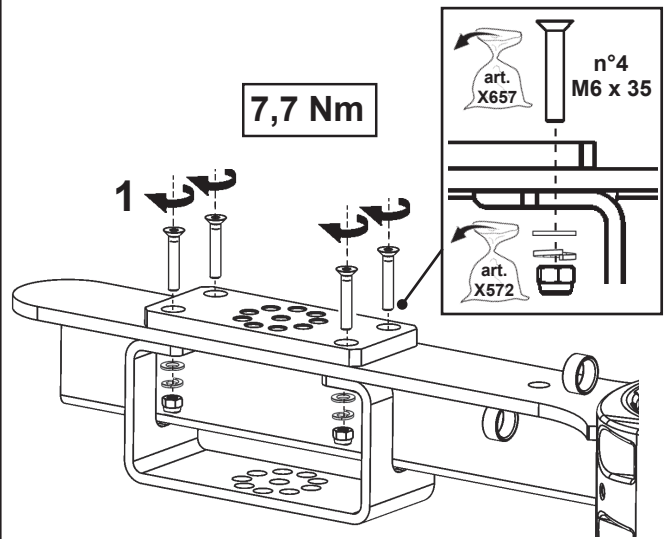

# MAXIWOODY:

## CONFIGURATIONS INSTALLATIONS ALLOWED

### MAXIWOODY

 +  (for "UP" application)  
art. X657

 +  (for "DOWN" application)  
art. X572

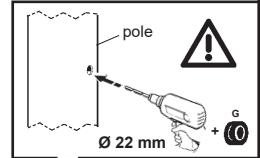
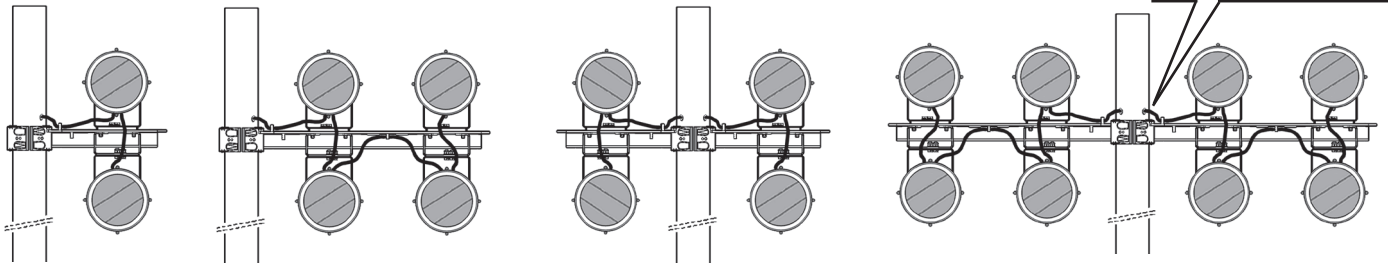
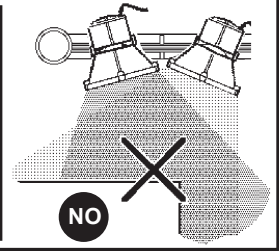
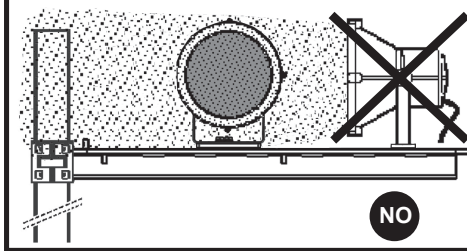

### MAXIWOODY

 +  (for "UP" application)  
art. X657

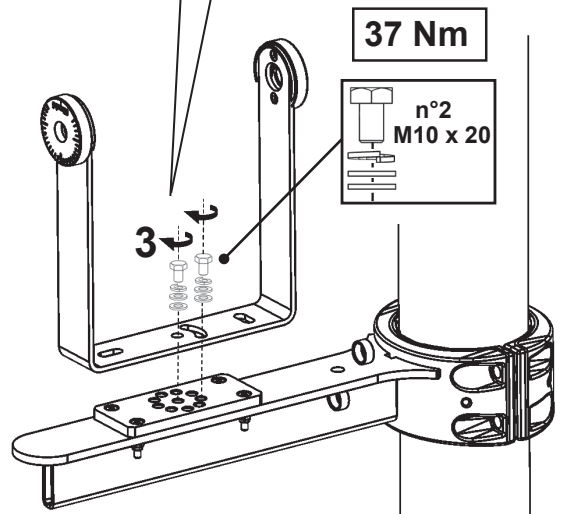
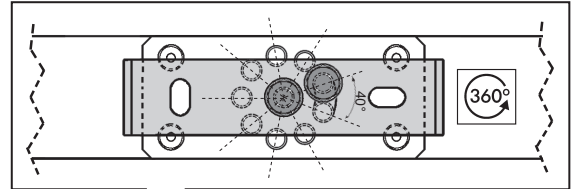
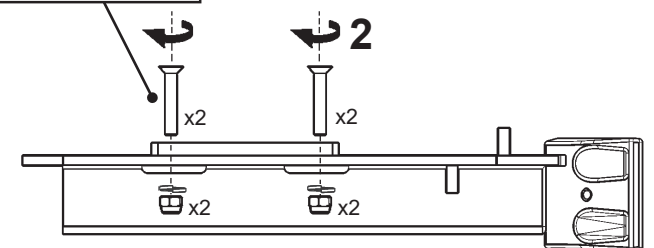
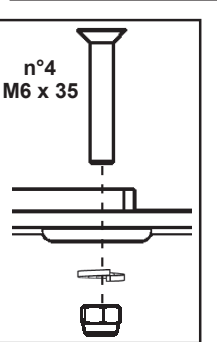
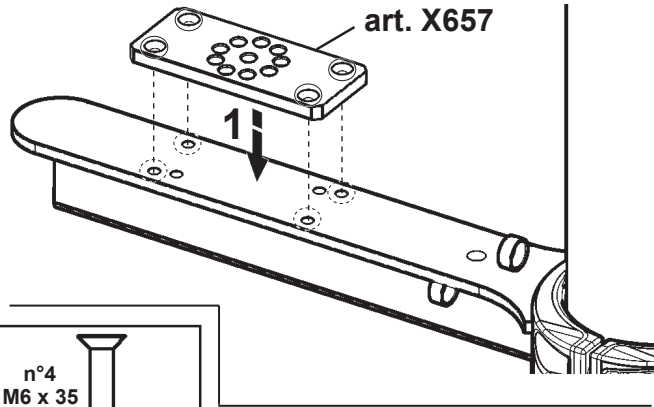

# MAXIWOODY

 +  (for "DOWN" application)  
art. X572

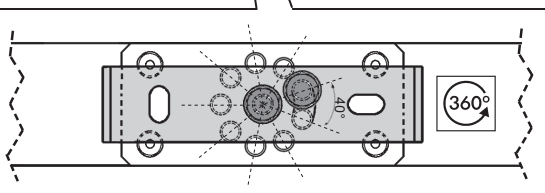
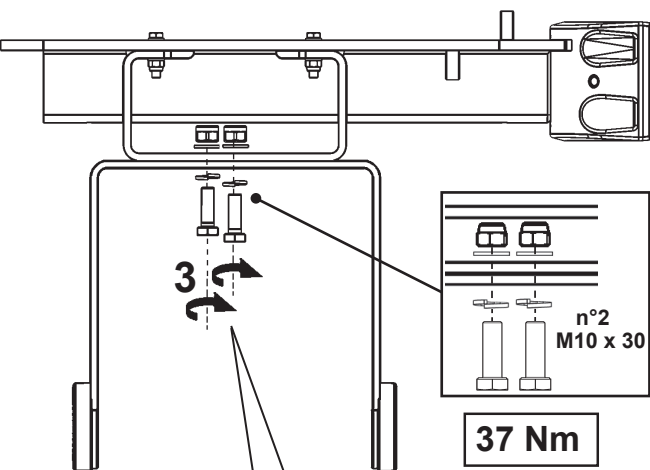
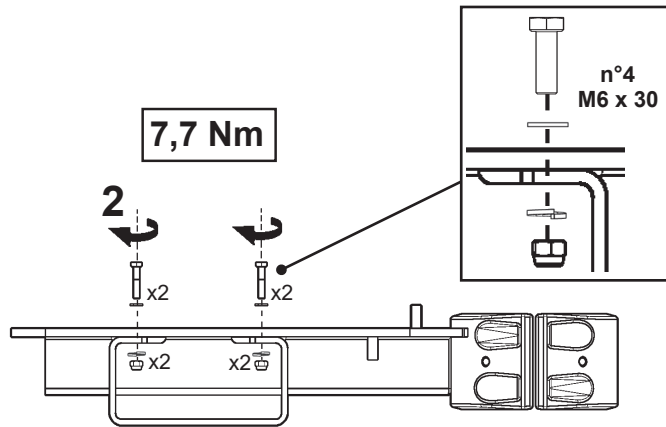
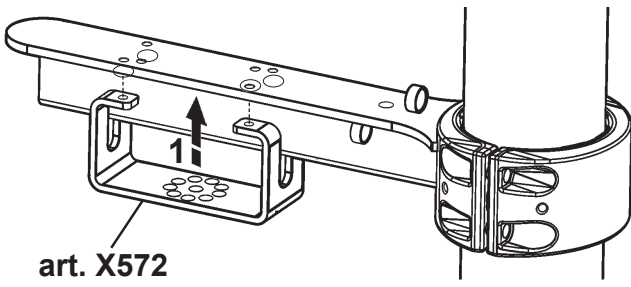

# MAXIWOODY

 +  (for "UP/DOWN" application)  
art. X657 + art. X572

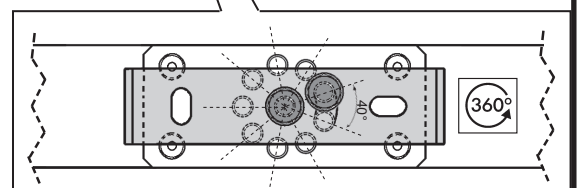
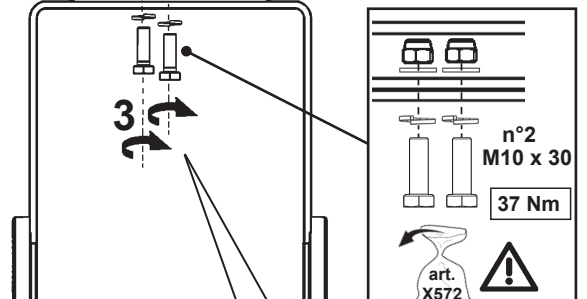
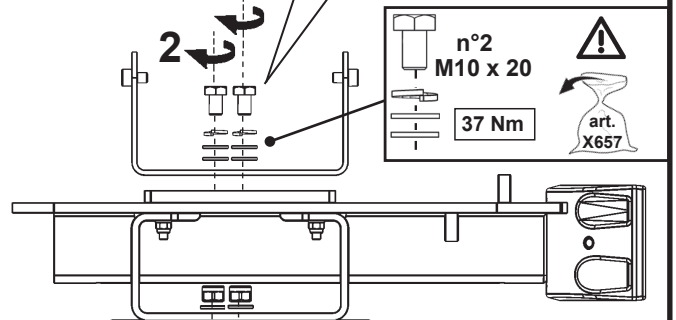
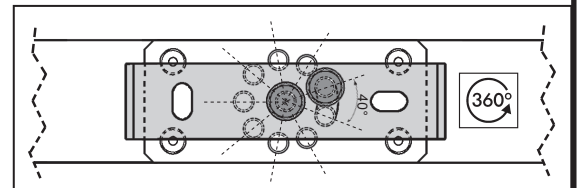
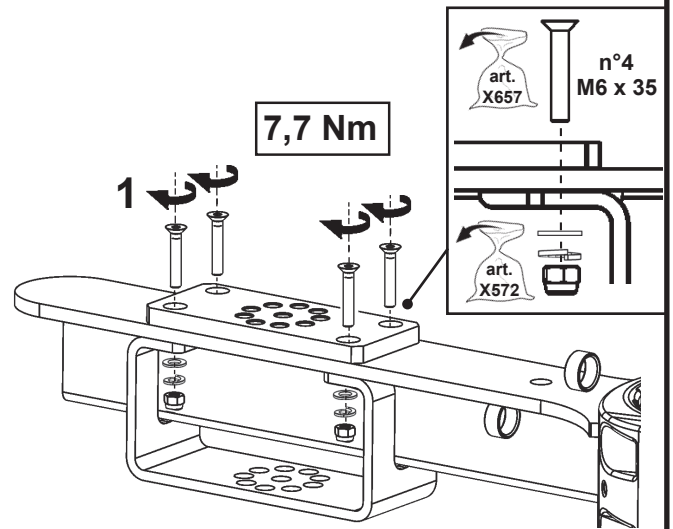

## CONFIGURATIONS INSTALLATIONS ALLOWED

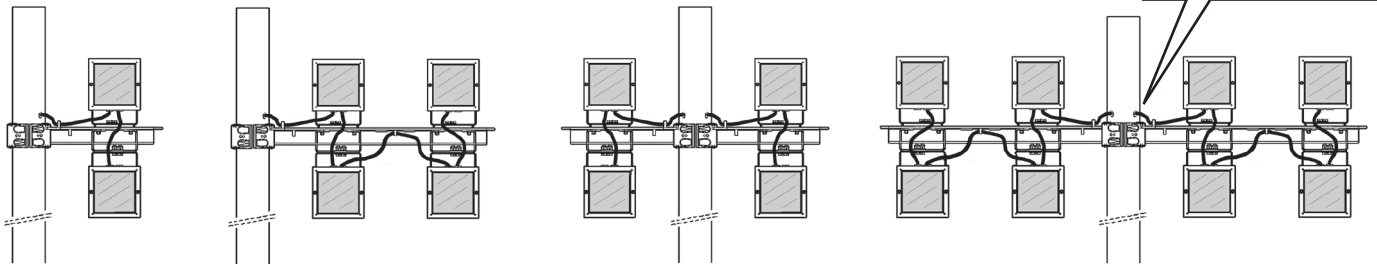
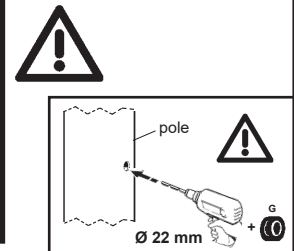
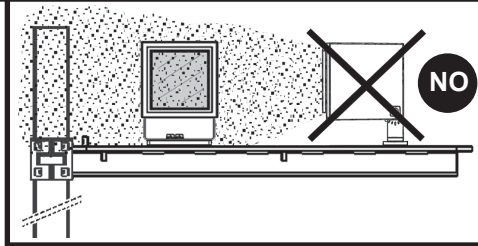

### iPRO

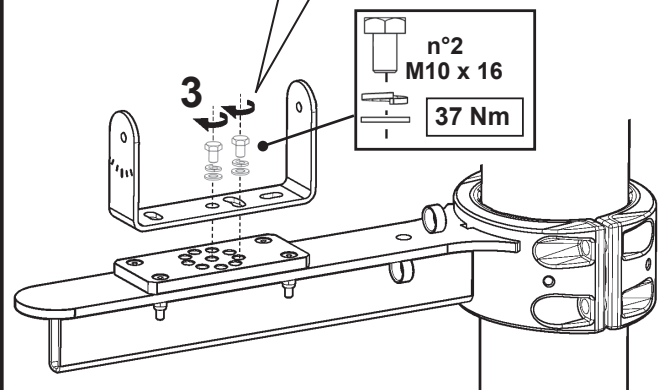
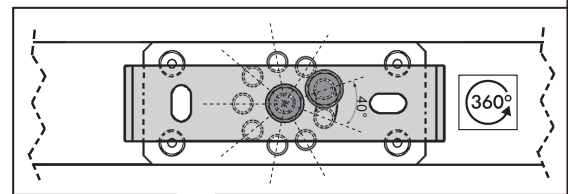
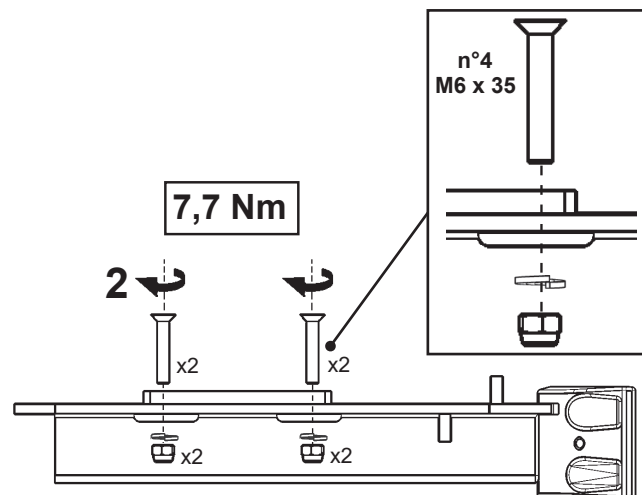
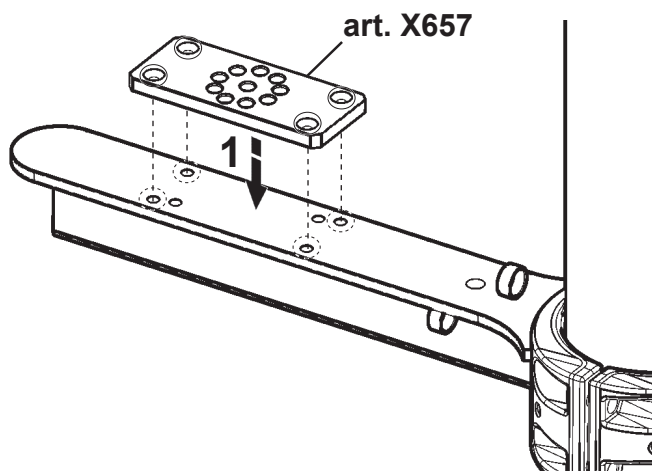

# iPRO

 +  (for "DOWN" application)  
art. X572

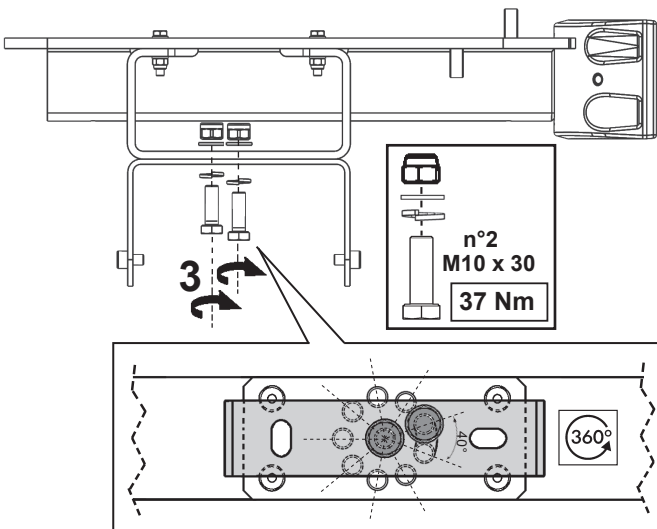
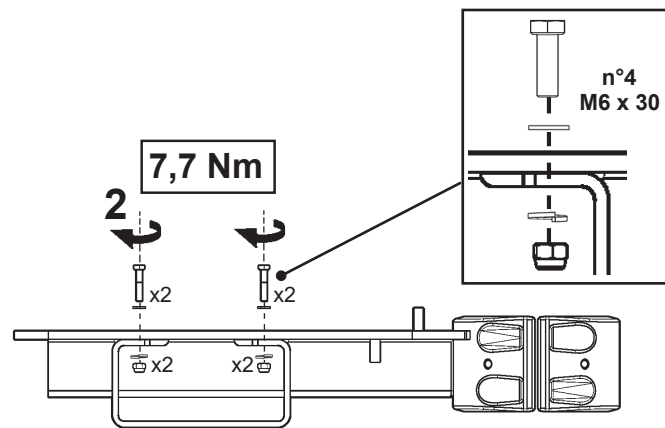
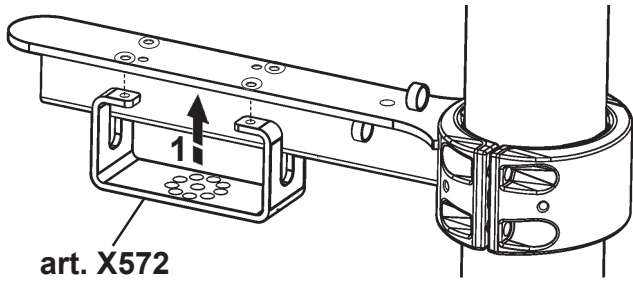

# iPRO

 +  +  (for "UP/DOWN" application)  
art. X657 art. X572

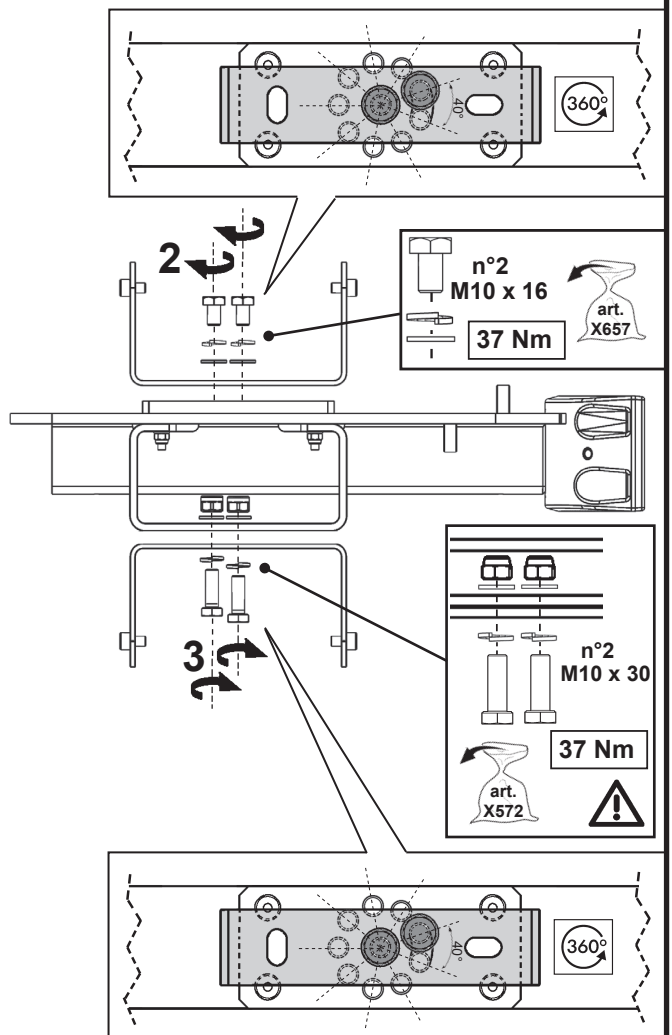
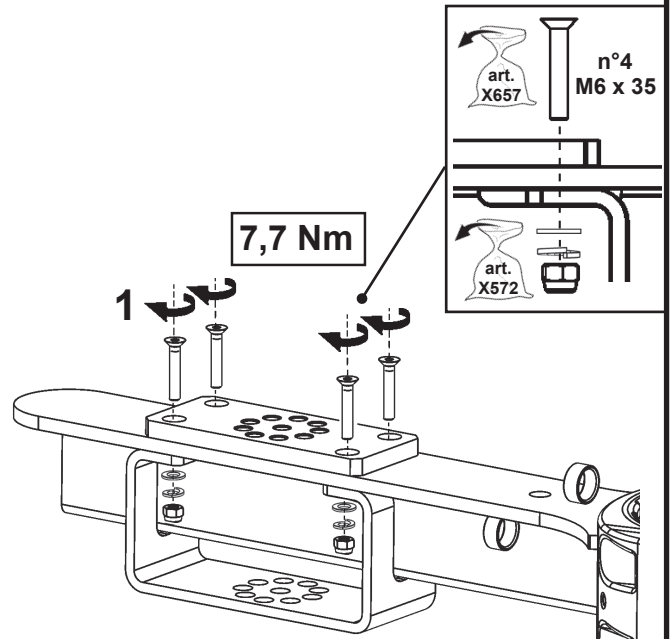

# LINGOTTO - PALCO IN-OUT E FRAMER:

## CONFIGURATIONS INSTALLATIONS ALLOWED

PALCO IN-OUT  
E FRAMER



LINGOTTO  
WITH BASE

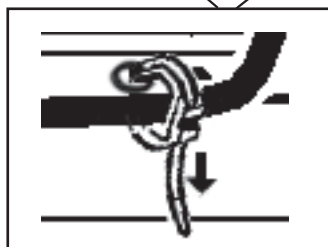
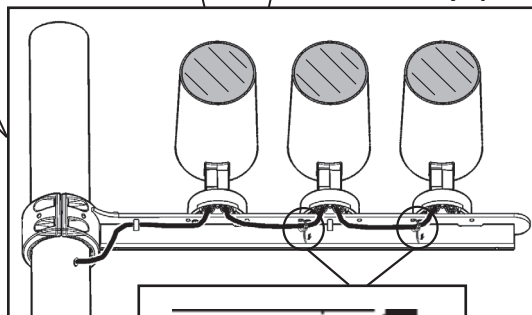
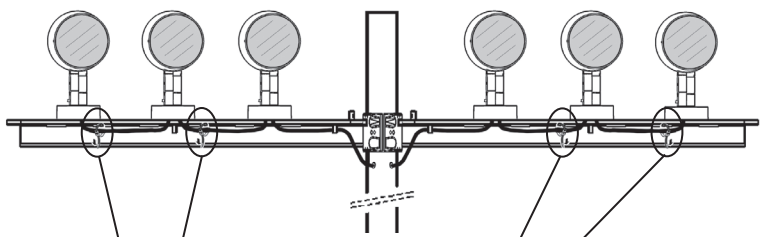
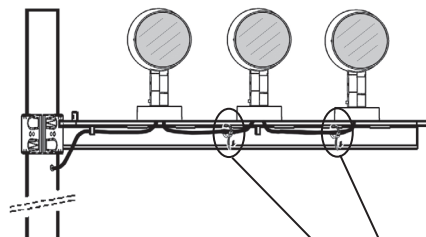
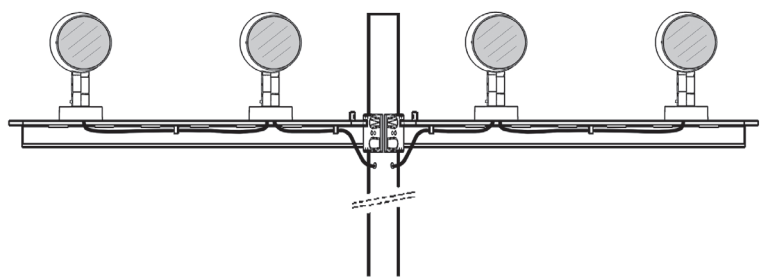
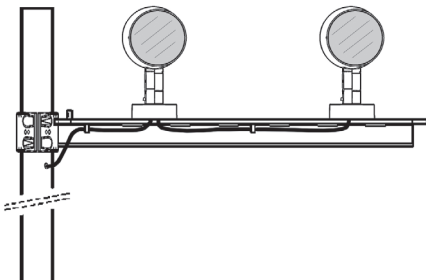
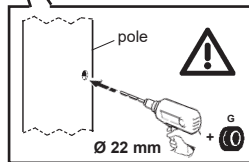
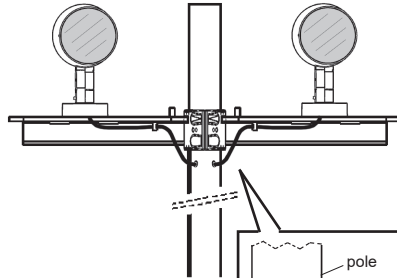
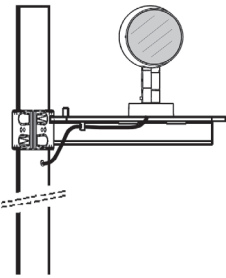
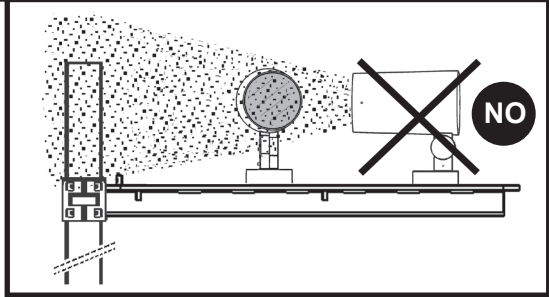
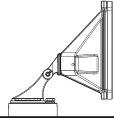



### PALCO IN-OUT E FRAMER



### LINGOTTO WITH BASE

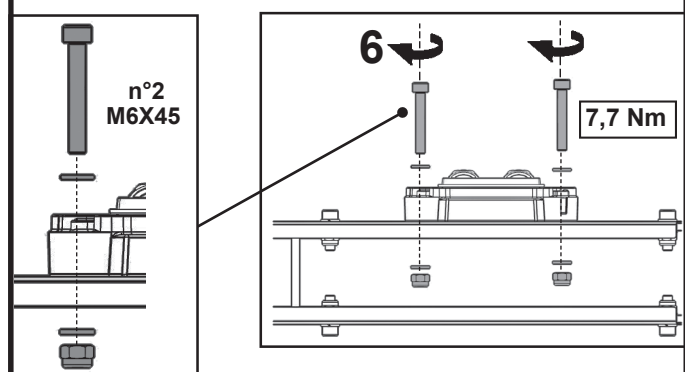
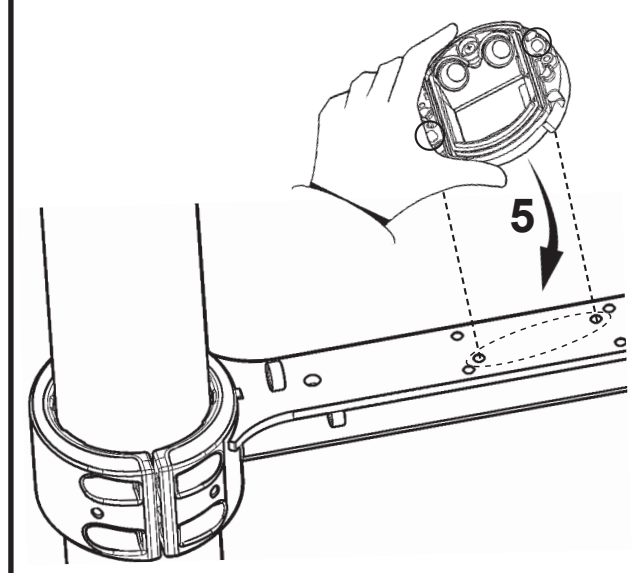
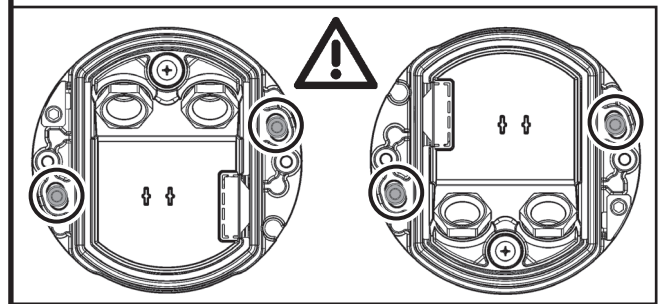
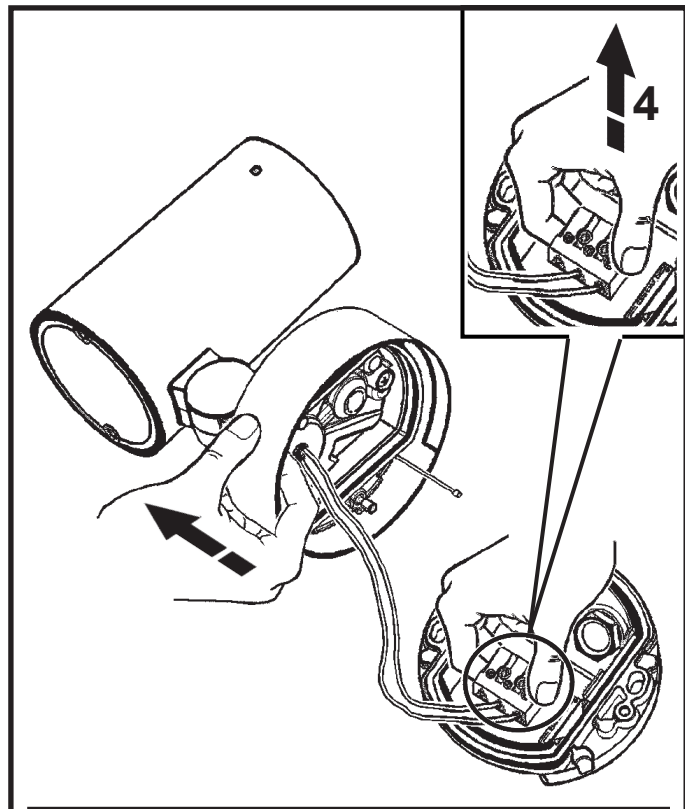
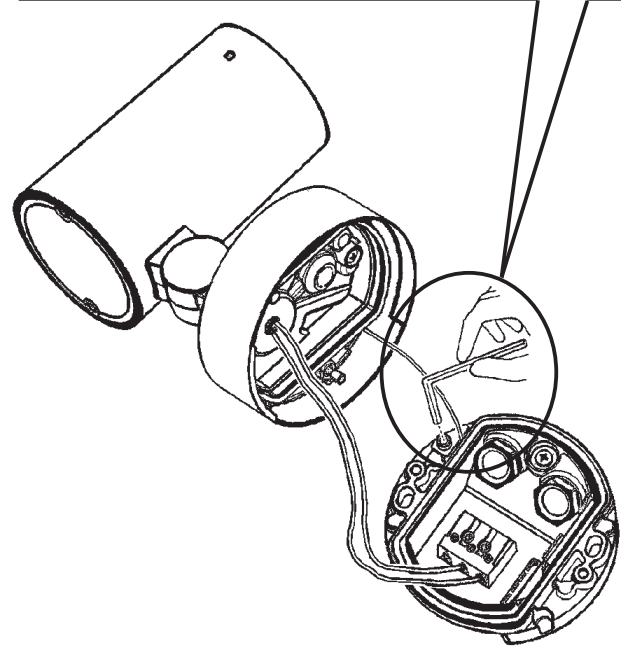
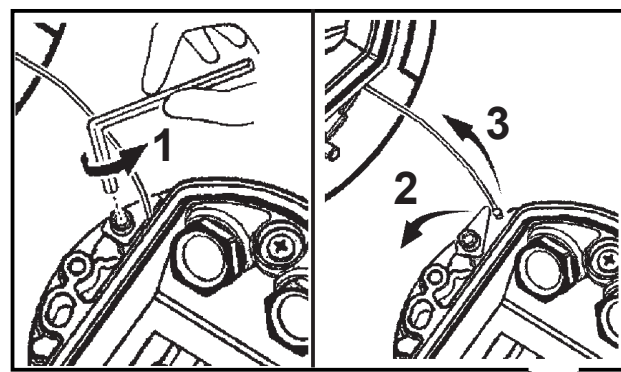
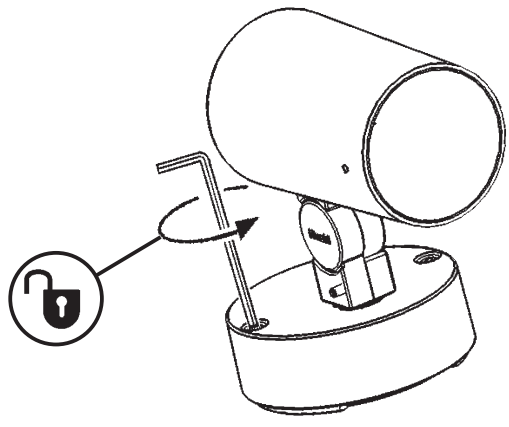
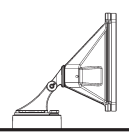

# PLATEA PRO:

## CONFIGURATIONS INSTALLATIONS ALLOWED

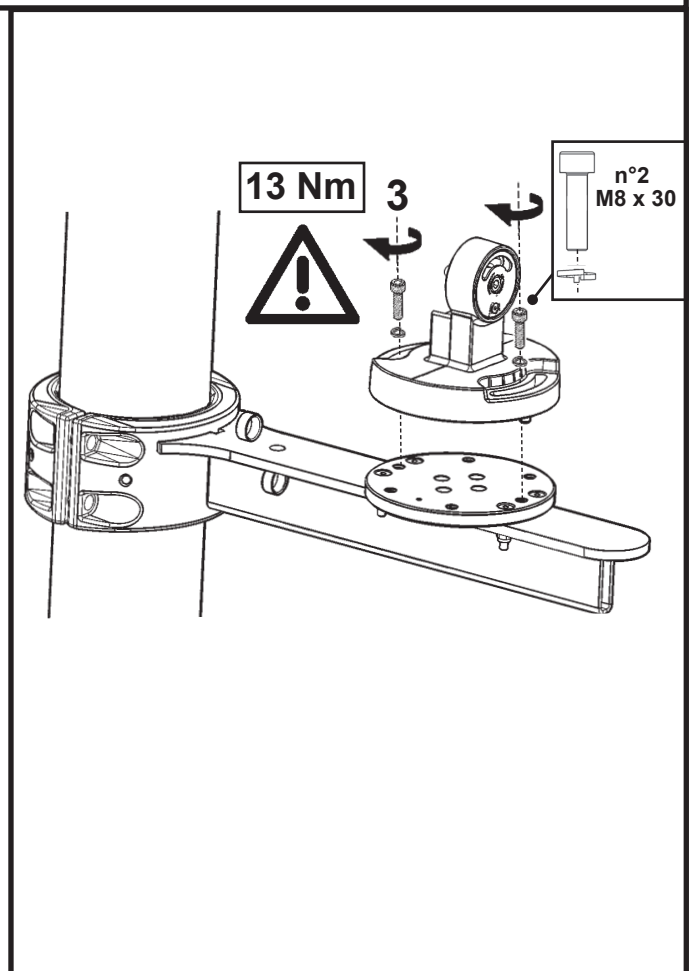
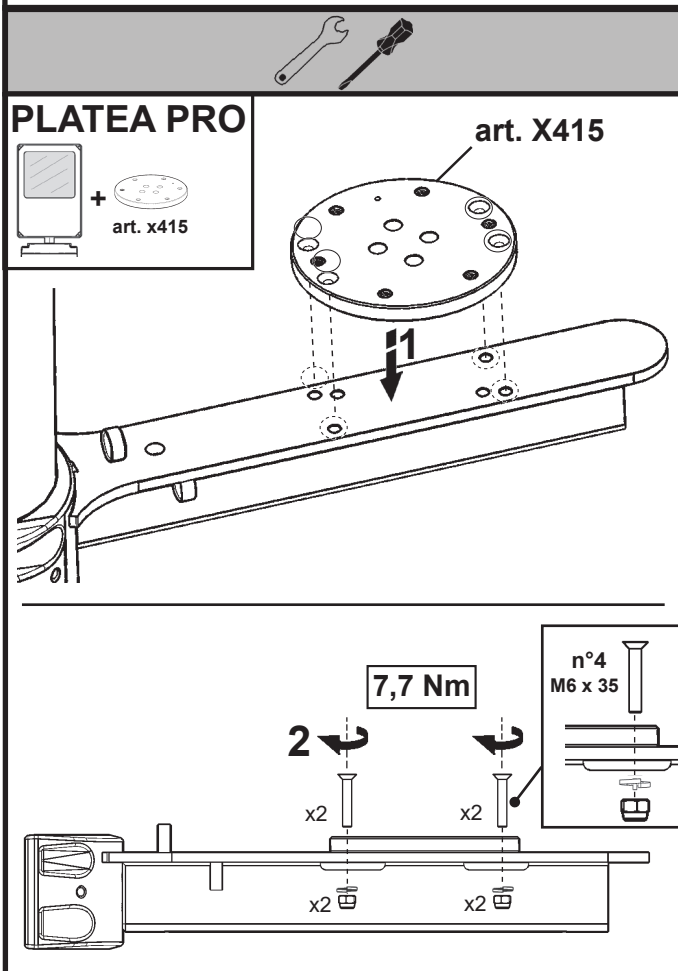
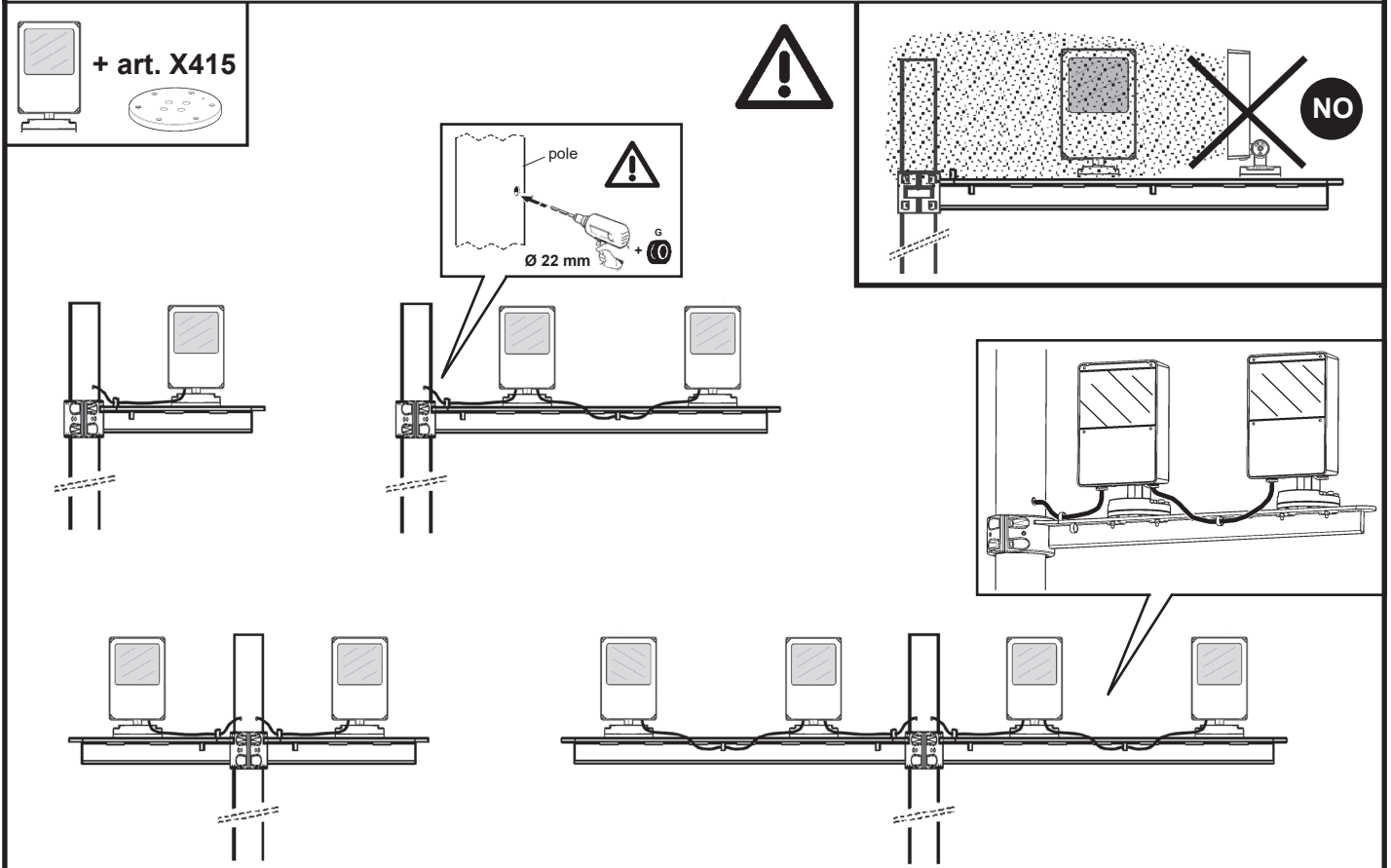



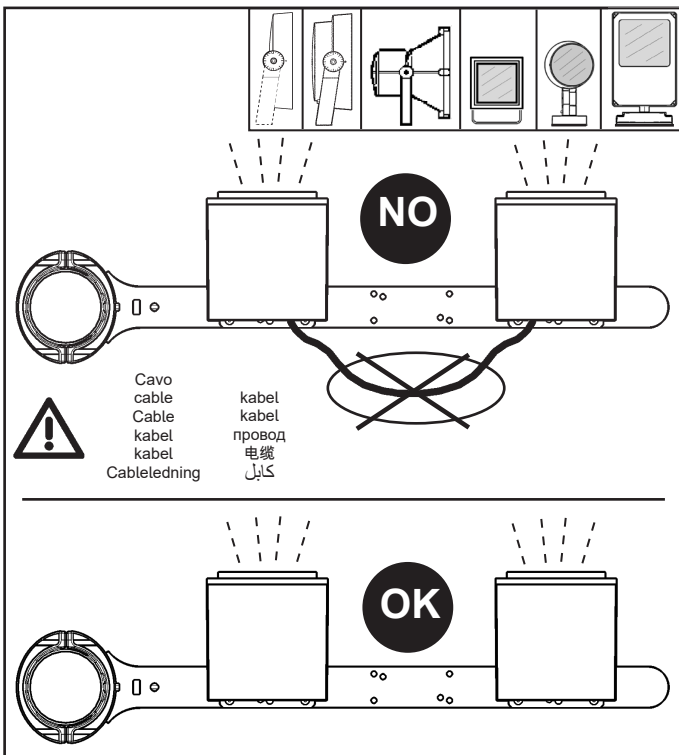
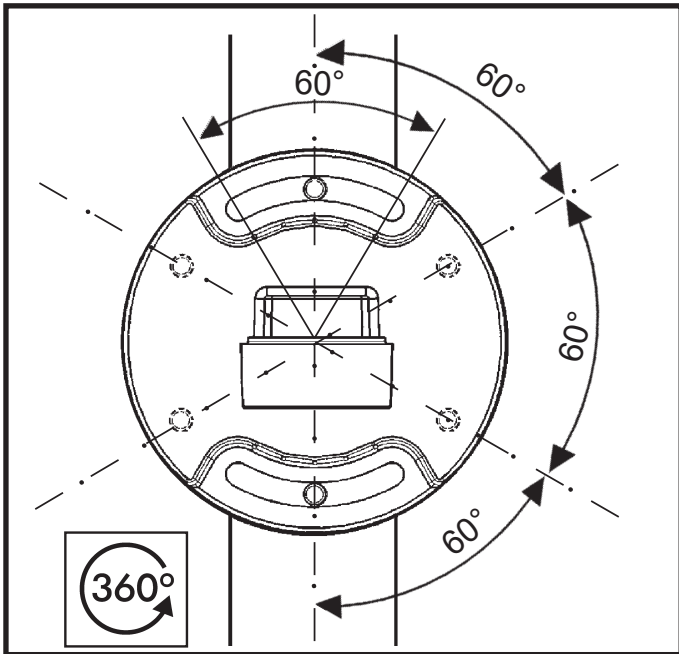

### ART. 6163 - 6164

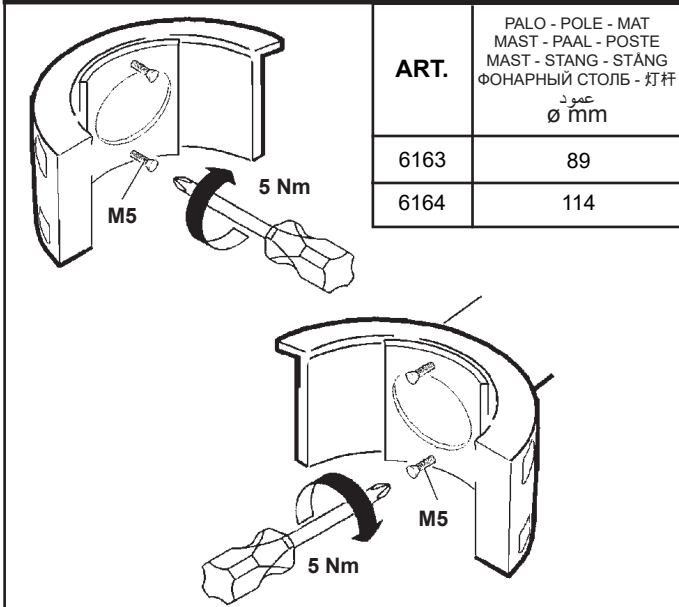

- IT** Per le posizioni di installazione, attenersi a quelle illustrate, eventualmente contattare la iGuzzini.
- EN** All installation positions must comply with those illustrated. In the event of any doubt, contact iGuzzini.
- FR** Pour les positions d'installation, se conformer aux positions illustrées ; contacter la société iGuzzini en cas de nécessité.
- DE** Für die Einbaupositionen die Abbildungen beachten. Eventuell iGuzzini kontaktieren.
- NL** Houd u voor de installatieposities aan degene die zijn weergegeven. Neem eventueel contact op met iGuzzini.
- ES** Respetar las posiciones de instalación ilustradas y, en caso de duda, contactar con iGuzzini.
- DA** For installationspositioner skal man holde sig til de viste, og eventuelt kontakte iGuzzini.
- NO** For installasjonsplasseringene henviser vi til illustrasjonene, eller ta eventuelt kontakt med iGuzzini.
- SV** Följ de angivna positionerna för installationen. Kontakta vid behov iGuzzini.
- RU** При выборе положения для монтажа следует обратиться к проиллюстрированным либо обратиться в компанию iGuzzini.
- ZH** 安装位置请参考图示，必要时也可联系iGuzzini.
- AR** في ما يتعلق بأوضاع التركيب، التزم بما هو موضح ومحدد، إذا دعت الضرورة اتصل ب iGuzzini

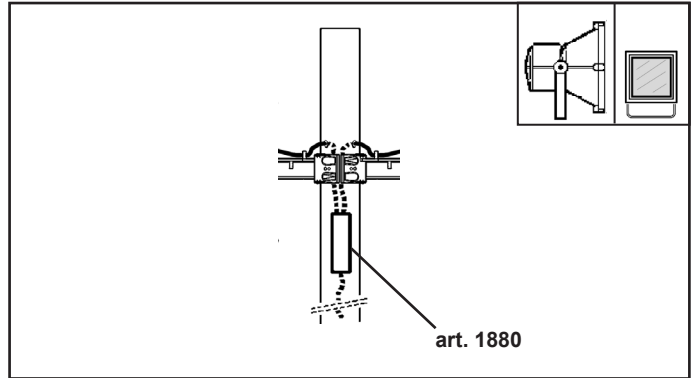

- IT** Per il cablaggio elettrico fare riferimento al foglio istruzioni del prodotto.
- EN** Please refer to the product instruction sheet for the electric wiring.
- FR** Informations zur elektrischen Verkabelung können Sie der Montageanleitung des Produkts entnehmen.
- DE** Die Membran nur an den für den Kabeldurchgang verwendeten Löchern durchstoßen.
- NL** PVoer de elektrische bedrading raadpleegt u het instructieblaadje in het product.
- ES** Para el cableado eléctrico hágase referencia a la hoja de instrucciones del producto.
- DA** Membranen må kun gennembrydes ved de huller, der skal anvendes til kabelføring.
- NO** Indhent opplysninger om ledningsføringen i produktets vejledning.
- SV** Angående kabeldragningen, se produktens instruktionsblad.
- RU** Порядок монтажа электропроводки смотрите в инструкциях к продукту.
- ZH** 针对布线，请参阅产品说明表。
- AR** بالنسبة للأسلاك الكهربائية، راجع ورقة تعليمات المنتج.