

iGuzzini

BLADE "R"

accessories



<https://qrco.de/bctUCI>



art. PC43

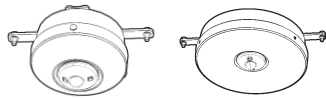

art. PB06 - PB07

IT ATTENZIONE:

LA SICUREZZA DELL'APPARECCHIO E' GARANTITA SOLO CON L'USO APPROPRIATO DELLE SEGUENTI ISTRUZIONI; PERTANTO E' NECESSARIO CONSERVARLE.

EN WARNING:

THE SAFETY OF THIS FIXTURE IS GUARANTEED ONLY IF YOU COMPLY WITH THESE INSTRUCTIONS; REMEMBER TO CONSERVE IN A SAFE PLACE.

FR ATTENTION:

LASÉCURITÉ DEL'APPAREIL N'EST GARANTIE QU'EN CAS D'UTILISATION CORRECTE DES INSTRUCTIONS SUIVANTES; IL FAUT PAR CONSEQUENT LES CONSERVER.

DE ACHTUNG:

DIE SICHERHEIT DES GERÄTES WIRD NUR DURCH SACHGEMÄSSE BEFOLGUNG NACHSTEHENDER ANWEISUNGEN GEWÄHRLEISTET; IHRE AUFBEWAHRUNG IST DESHALB SEHR WICHTIG.

NL OPGELET:

DE VEILIGHEID VAN DI ATOESTEL IS SLECHTS DAN GEGARANDEERD ALS INDIEN DE VOLGENDE INSTRUCTIES STRIKT WORDEN TOEGEPAST; DAAROM MOET MEN ZE OOK BEWAREN.

ES ATENCION:

LA SEGURIDAD DEL APARATO SE GARANTIZA SOLO CUMPLIENDO CUIDADOSAMENTE LAS SIGUIENTES INSTRUCCIONES; POR ELLO, ES NECESARIO CONSERVARLAS.

DA BEMÆRK:

SIKKERHEDEN VED BRUG AF ARMATURET KAN KUN GARANTERES, HVIS DISSE ANVISNINGER FØLGES; SØRG DERFOR FOR AT GEMME DEM.

NO ADVARSEL:

SIKKERHETEN TIL DETTE APPARATET GARANTERES KUN HVIS DU OVERHOLDER DISSE INSTRUKSJONENE; HUSK Å OPPBEVARE DEM PÅ ET TRYGT STED.

SV OBSERVERA!

UTRUSTNINGENS SÄKERHET KAN ENDAST GARANTERAS OM DESSA ANVISNINGAR RESPEKTERAS I DETALJ. SPARA DÄRFÖR DESSA ANVISNINGAR FÖR FRAMTIDA KONSULTATION.

RU ВНИМАНИЕ:

МЫ ГАРАНТИРУЕМ БЕЗОПАСНУЮ ЭКСПЛУАТАЦИЮ ИЗДЕЛИЯ ТОЛЬКО ПРИ СОБЛЮДЕНИИ СЛЕДУЮЩИХ ИНСТРУКЦИЙ; С ЭТОЙ ЦЕЛЬЮ НЕОБХОДИМО СОХРАНИТЬ ДАННУЮ БРОШЮРУ.

ZH 警告

为确保该装置安全，请遵守操作指示；并于安全场所放置。

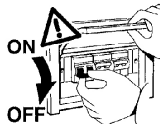

IT N.B.: DURANTE L'INSTALLAZIONE DEL SISTEMA RISPETTARE SCRUPOLOSAMENTE LE NORME IMPIANTISTICHE NAZIONALI VIGENTI.

EN N.B.: WHEN INSTALLING THE SYSTEM, MAKE SURE ALL CURRENT NATIONAL REGULATIONS RELATING TO INSTALLATION ARE OBSERVED.

FR N.B.: LORS DE L'INSTALLATION DU SYSTÈME VEUILLEZ RESPECTER RIGOREUSEMENT LES NORMES EN VIGUEUR EN LA MATIÈRE DANS LE PAYS.

DE N.B.: BEACHTEN SIE BEI DER INSTALLATION DES SYSTEMS UNBEDINGT DIE IM LAND GELTENDEN ANLAGETECHNISCHEN VORSCHRIFTEN.

NL N.B.: BIJ HET INSTALLEREN VAN HET SYSTEEM MOET U DE GELDENDE NATIONALE INSTALLATIENORMEN STRIKT NALEVEN.

ES NOTA: DURANTE LA INSTALACIÓN DEL SISTEMA RESPETAR ESCRUPULOSAMENTE LAS NORMAS NACIONALES DE INSTALACIÓN EN VIGOR.

DA N.B.: UNDER INSTALLATION AF SYSTEMET SKAL MAN NØJE OVERHOLDE DE GÆLDENDE REGLER FOR DISSE ANLÆG.

NO N.B.: UNDER INSTALLASJON AV SYSTEMET MÅ DE NASJONALE ANLEGGSFORSKRIFTENE OVERHOLDES NØYE.

SV OBS! UNDER INSTALLATIONEN AV SYSTEMET SKA GÄLLANDE NATIONELLA INSTALLATIONSFÖRESKRIFTER RESPEKTERAS I DETALJ.

RU ПРИМЕЧАНИЕ: В ПРОЦЕССЕ МОНТАЖА СИСТЕМЫ СТРОГО СОБЛЮДАЙТЕ НАЦИОНАЛЬНЫЕ ДЕЙСТВУЮЩИЕ НОРМАТИВЫ ПО ЭЛЕКТРОПРОВОДКЕ.

ZH 重要：安装系统时请始终参照标准系统

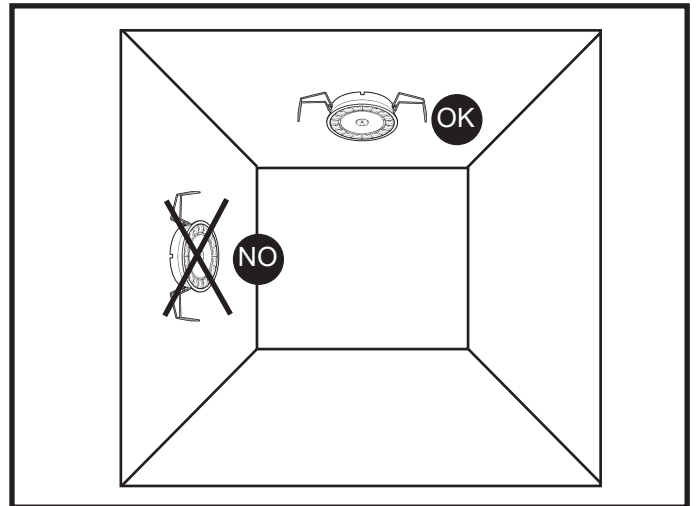

IT Per le posizioni di installazione, attenersi a quelle illustrate, eventualmente contattare la iGuzzini.

EN All installation positions must comply with those illustrated. In the event of any doubt, contact iGuzzini.

FR Pour les positions d'installation, se conformer aux positions illustrées ; contacter la société iGuzzini en cas de nécessité

DE Für die Einbaupositionen die Abbildungen beachten. Eventuell iGuzzini kontaktieren.

NL Houd u voor de installatieposities aan degene die zijn weergegeven. Neem eventueel contact op met iGuzzini

ES Respetar las posiciones de instalación ilustradas y, en caso de duda, contactar con iGuzzini

DA For installationspositioner skal man holde sig til de viste, og eventuelt kontakte iGuzzini

NO For installasjonsplassingene henviser vi til illustrasjonene, eller ta eventuelt kontakt med iGuzzini

SV Följ de angivna positionerna för installationen. Kontakta vid behov iGuzzini

RU При выборе положения для монтажа следует обратиться к проиллюстрированным либо обратиться в компанию iGuzzini

ZH 安装位置请参考图示，必要时也可联系iGuzzini



art. PB06

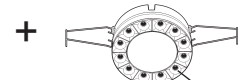

12x

<https://www.iguzzini.com/pb06/>



art. PB07

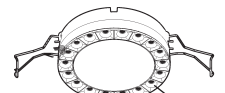

18x

<https://www.iguzzini.com/pb07/>



art. PC43

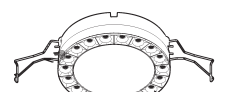

18x

<https://www.iguzzini.com/pc43/>

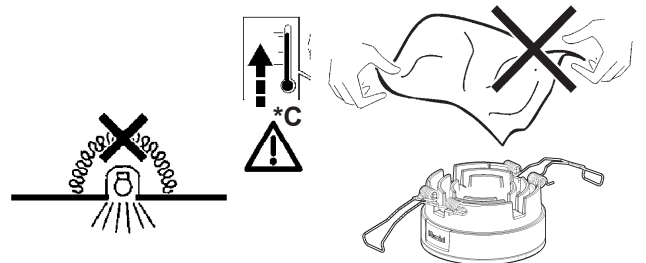

IT N.B.: Apparecchi non idonei ad essere coperti di materiale termicamente isolante

EN N.B.: Fixtures not suitable to be covered in thermally-insulating material.

FR N.B.: Appareils ne pouvant pas être couverts de matériau d'isolation thermique

DE N.B.: Geräte nicht geeignet, um mit wärmeisolierendem Material abgedeckt zu werden

NL N.B.: Deze apparaten zijn niet geschikt om te worden bedekt met thermisch isolerend materiaal

ES NOTA: Aparatos no aptos para ser cubiertos de material térmicamente aislante

DA N.B.: Armaturerne må ikke dækkes af varmeisolerende materiale.

NO N.B.: Apparatene passer ikke til å dækkes av termoisolerende materialer.

SV OBS! Utrustningen får inte täckas över med värmeisolerande material

RU Внимание: Приборы непригодны для покрытия термоизоляционным материалом.

ZH 灯具不适宜用隔热材料加以覆盖。

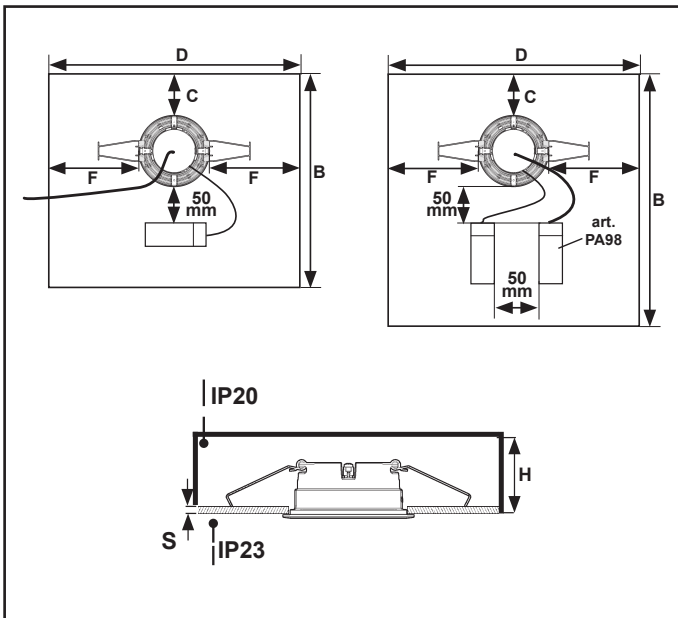

ART.	+ ACCESSORIES	C mm	F mm	D mm	B mm	H mm
12x	PB06	50	80	285	418	200
18x	PB07 PC43	50	100	370	470	

ART. PC43	V	mA
	DALI 2 bus	9

ART. PB06 - PB07

Sensor Electrical Specifications

Input Voltage	Vin 12/24 Vdc(for models without powersupply)
Input Current	35mA @12VDC 25ma@24VDC

IT La conformità alla norma è garantita soltanto utilizzando gruppi driver iGuzzini (art.: PA98). Nel caso di utilizzo di driver diversi, per tutte le informazioni tecniche aggiuntive, contattare la iGuzzini

EN Conformity with the standard is guaranteed only if iGuzzini driver assemblies (item code PA98) are used. When using other drivers, contact iGuzzini for any additional technical information

FR La conformité à la norme n'est assurée qu'en cas d'utilisation de blocs drivers iGuzzini (réf. : PA98). Si vous utilisez des drivers différents, pour toute information technique supplémentaire, veuillez contacter iGuzzini

DE Die Übereinstimmung mit der Vorschrift ist nur mit dem Einsatz von iGuzzini-Drivergruppen (Art.: PA98) gewährleistet. Werden andere Treiber verwendet, ist für sämtliche zusätzlichen technischen Informationen iGuzzini zu Rate zu ziehen.

NL De conformiteit aan de norm wordt alleen gegarandeerd als u iGuzzini driver groepen gebruikt (art.: PA98). En caso de utilización de drivers diferentes, para conocer la información técnica adicional ponerse en contacto con iGuzzini

ES La conformidad a la norma se garantiza solamente con el uso de grupos driver iGuzzini (art. PA98). Voor het gebruik van andere drivers dient u contact op te nemen met iGuzzini voor alle verdere technische informatie

DA Opfyldelse af reglerne garanteres kun ved brug af driverenheder fra iGuzzini (art.: PA98). Hvis du anvender forskellige drivere, bedes du kontakte iGuzzini for alle de øvrige tekniske informationer

NO Samsvar med forskriften garanteres bare ved bruk av drivergrupper fra iGuzzini (art.: PA98). Ved bruk av forskjellige drivere, ta kontakt med iGuzzini for all ekstra teknisk informasjon

SV Överensstämmelse med standard garanteras endast genom att använda drivenheter av typ iGuzzini (art.: PA98). Vid användning av andra drivenheter ber vi att ni kontaktar iGuzzini för vidare teknisk information

RU Соответствие нормативу гарантируется только при использовании групп драйверов iGuzzini (арт.: PA98). Для получения необходимой технической информации при использовании других драйверов свяжитесь с компанией iGuzzini.

ZH 只有使用了IGUZZINI的驱动器系列 (PA98产品), 产品的合格性才能被保证 如果使用其他驱动器, 请联系iGuzzini公司了解所有其他技术信息。

IT Cablare alla rete elettrica l'alimentatore solo dopo aver effettuato il collegamento ai prodotti

EN Wire the ballast to the power supply network only once it has been connected to the products

FR N'effectuer le câblage du ballast au réseau électrique qu'après avoir effectué le raccordement aux produits

DE Schließen Sie das Vorschaltgerät erst nach der Verdrahtung an den Produkten am Stromnetz an.

NL Cablear el alimentador a la red eléctrica sólo después de realizar la conexión de los productos.

ES Verbind het voorschakelapparaat alleen aan op het elektriciteitsnet nadat u alle producten heeft aangesloten.

DA Tilslut først strømforsyningsenheden til strømforsyningsnettet, efter at have foretaget tilslutningen til produkterne.

NO Kable transformatoren til el-nettet bare etter at produktene er tilkoblet

SV Anslut strömförsörjningsanordningen till elnätet först efter att anslutningen till produkterna har utförts.

RU Подсоединить к электросети блок питания только после подсоединения к приборам.

ZH 仅在镇流器连接到产品的时候才将其连接至电源网络

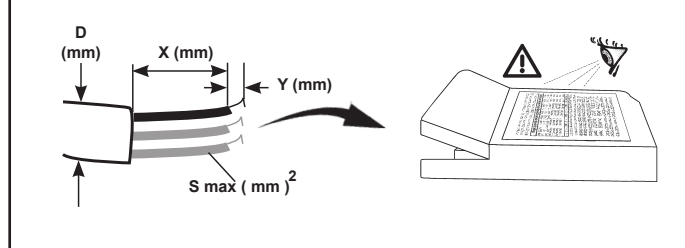

ART. PA98	S mm ²	Y mm	X mm	D mm
	0,5 - 2,5	5 - 6	8	3 - 8

I Per il collegamento elettrico fare riferimento alla marcatura dell'alimentatore.

EN Refer to the marking on the power unit for the electrical connection.

FR Pour le raccordement électrique se reporter au marquage du ballast.

DE Den Anschluss an das Stromnetz gemäß Kennzeichnung auf dem Vorschaltgerät ausführen.

NL Voor de elektrische aansluiting wordt verwezen naar de marking op de stroomvoorziening.

ES Para la conexión eléctrica hacer referencia a las informaciones marcadas en el alimentador.

DA For elektrisk tilslutning, se strømforsynings mærkning.

NO For elektrisk tilkobling, se merking på strømforsyningsenheten.

SV För elanslutningen se till märkningen på nåtdelen.

RU Для электрического подключения смотреть маркировку на блоке питания.

ZH 连接电线时请参考供电装置上的标记。

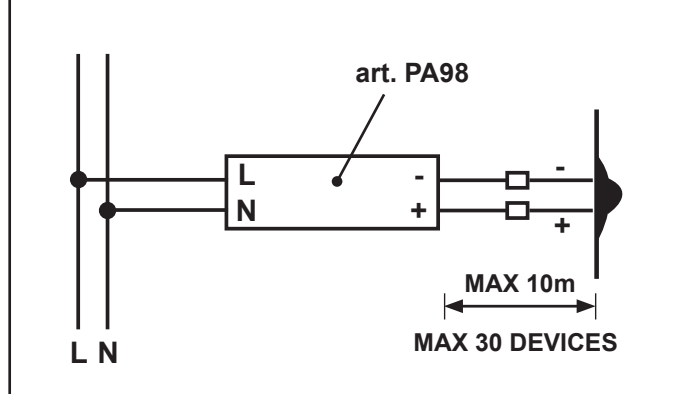

+ ART. PA98

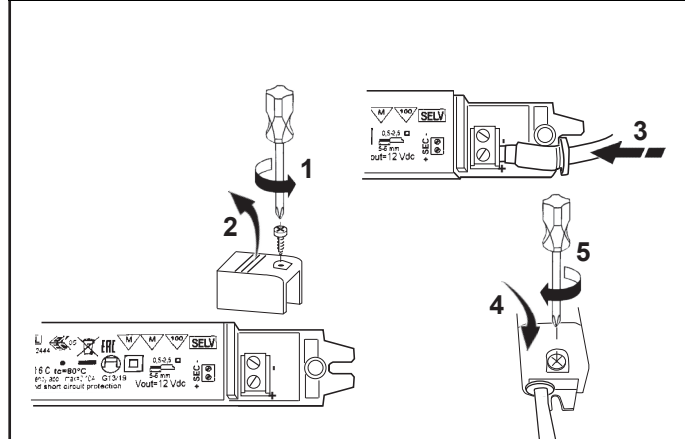

ART. PC43

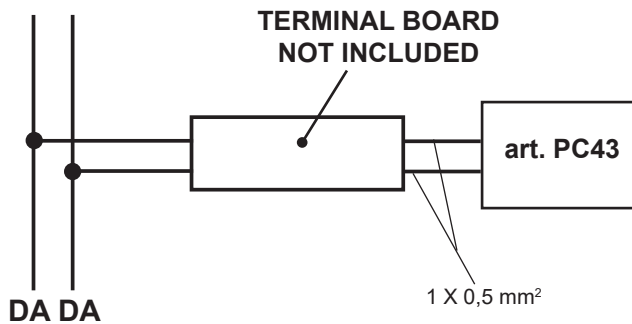

IT Morsetti non inclusa. L'installazione può richiedere l'intervento di personale qualificato (Fase A).

Caratteristiche tecniche della morsetti: - n° 2 morsetti del tipo a vite (sezione max. 2,5 mm²) - tensione di alimentazione 250V - 6A. - spellatura cavi di 8 mm. - dispositivo idoneo per la classe seconda. - IP23

EN Terminal board not included. The aid of qualified personnel may be required for installation (Phase A).

Technical features of the terminal board: - 2 terminals with a screw base (max. cross-section 2.5 mm²) - 250 V - 6 A supply voltage. - 8 mm cable stripping length - Device suitable for class two. - IP23

FR Bornier non inclus. L'installation pourrait exiger l'intervention de personnel qualifié (Phase A).

Caractéristiques techniques du bornier :
- 2 bornes à vis (section maxi 2,5 mm²) - tension d'alimentation 250V - 6A.
- dénudage des câbles de 8 mm. - dispositif approprié classe deux. - IP23

DE Klemmenleiste nicht enthalten. Die Installation muss gegebenenfalls von Fachkräften durchgeführt werden (Phase A).

Technische Merkmale der Klemmenleiste:
- 2 Schraubklemmen (Querschnitt max. 2,5 mm²) - Versorgungsspannung 250V - 6A
- Kabelabisolierung 8 mm. - Für die Klasse II geeignetes Gerät. - IP23

NL Klemmenstrook niet inbegrepen. De installatie kan de hulp van gekwalificeerde installateurs vereisen (Fase A).

Technische eigenschappen van de klemmenstrook:
- 2 klemmen van het schroeftype (max. diameter 2,5 mm²) - voedingsspanning 250V - 6A
- strippen kabels 8 mm. - apparaat geschikt voor de tweede klasse. - IP23

ES Clema de conexiones no incluida. La instalación puede necesitar la intervención de personal calificado (Fase A).

Características técnicas de la clema de conexiones:
- n. 2 terminales de tornillo (sección máx. 2,5 mm²) - tensión de alimentación 250V - 6A
- peladura cables de 8 mm. - dispositivo idóneo para la clase segunda. - IP23

DA Klemkasse følger ikke med. Installation kan kræve hjælp fra en elektriker (Fase A).

Klemkassens tekniske karakteristika:
- 2 klemmer af skruetypen (maks. snit 2,5 mm²) - forsyningspænding 250V - 6A
- skrælning af ledninger 8 mm. - egnet anordning til klasse to - IP23

NO Klemmbrett ikke inkludert. Installasjonen kan kreve inngrep av kvalifisert personale (Fase A).

Klemmbrettets tekniske egenskaper:
- n° 2 klemmskruer av typen med skruer (maksimalt tværsnitt 2,5 mm²) - matespenning på 250V ~ 6A. - kabelfjerning på 8 mm. - innretning passende for annen klasse. - IP23

SV Kopplingsplint ingår inte. Installationen kan kräva ingrepp från en utbildad fackman (fas A).

Kopplingsplintens tekniska egenskaper:
- 2 st. skruvklämmor (max. tvärsnitt 2,5 mm²). - Matningsspänning 250 V - 6 A.
- Kabelavskalning 8 mm. - Godkänd anordning enligt klass 2. - IP23

RU Без клеммной колодки. Для монтажа может потребоваться вызвать квалифицированного электрика (Фаза А).

Технические характеристики клеммной коробки:
- 2 клеммные винтовые коробки (макс. сечение 2,5 мм²) - напряжение питания 250В - 6А. - непокрытые провода 8 мм. - соответствующее устройство для второго класса - IP23

ZH 注意：不包括终端板。需要专业的技师进行安装。

接线排的技术特征：
- 2路接线排 (max.横截面2.5 mm²) - 承载电压250 V - 6°。 - 电线端头剥线8mm. - IP23

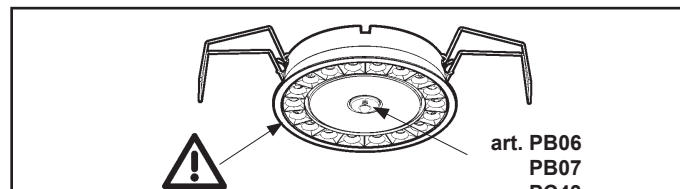
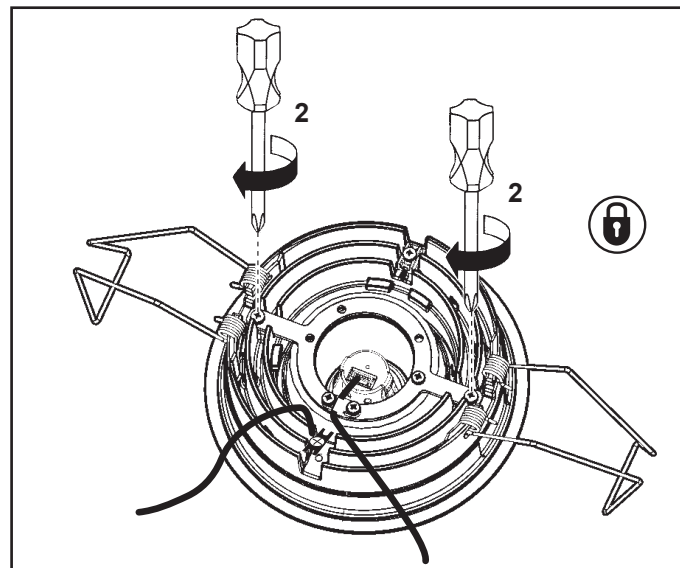
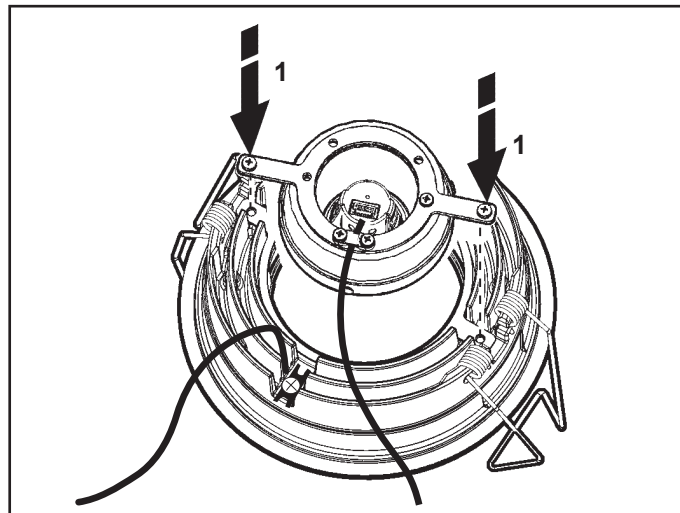

IT Per l'installazione degli incassi consultare il foglio istruzioni relativo.

EN For the installation of recessed fittings, please refer to the corresponding instruction sheet.

FR Pour l'installation des encastrés veuillez consulter la notice correspondante.

DE Zur Installation de Einbauleuchten halten Sie sich an die Angaben in der beigefügten Gebrauchsanweisung.

NL Voor de installatie van de verzonken inbouw, zie het bijbehorende instructieblad.

ES Para la instalación de las luminarias empotrables véase la relativa hoja de instrucciones.

DA Se den pågældende vejledning til installation af indbygningselementer.

NO For installasjon av fordypningsarmaturer, vennligst se tilhørende instruksjonsark.

SV För att installera inbyggnadsutrymna, se respektive instruktionsbladet.

RU Порядок монтажа встраиваемых приборов смотрите в соответствующих инструкциях.

ZH 安装嵌入装置时，请参见对应说明表。

MAINTENANCE

Minimal Version

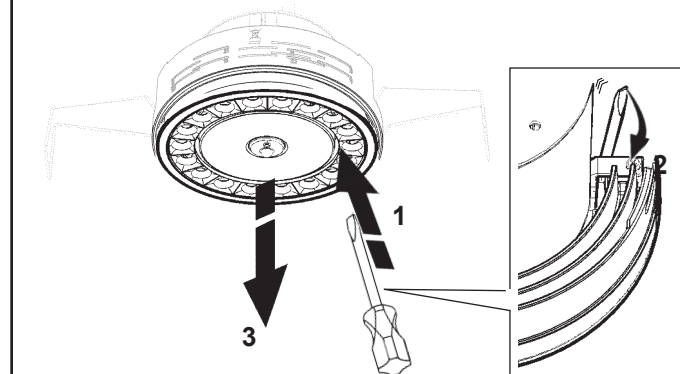

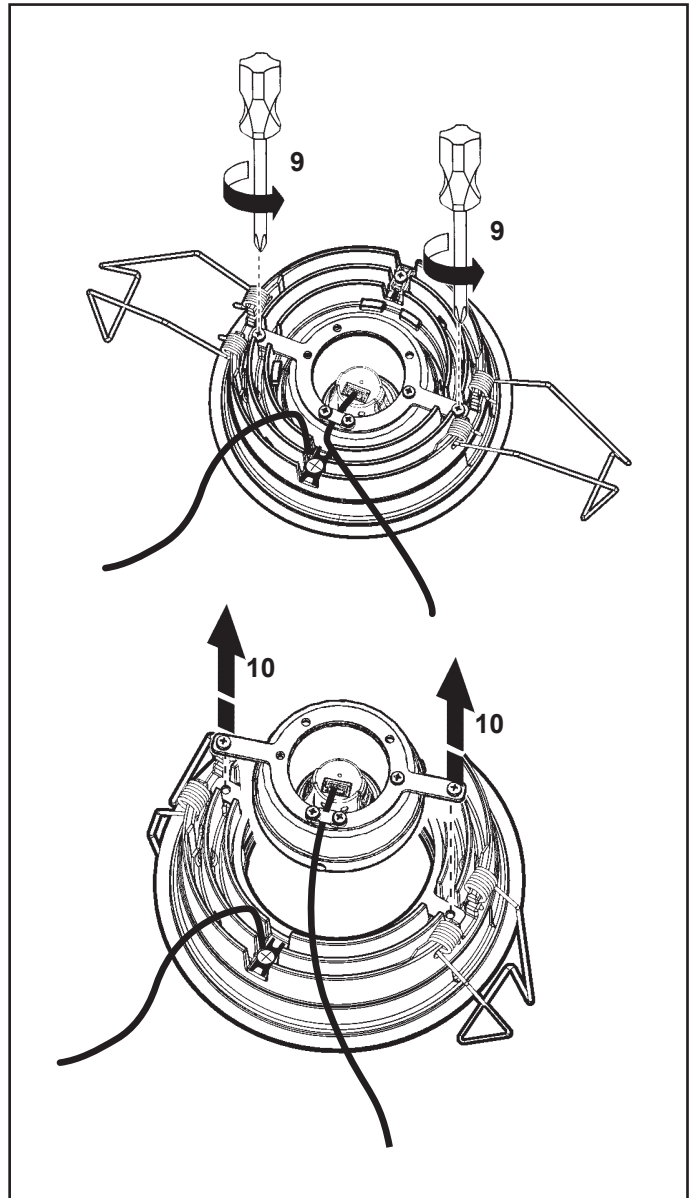
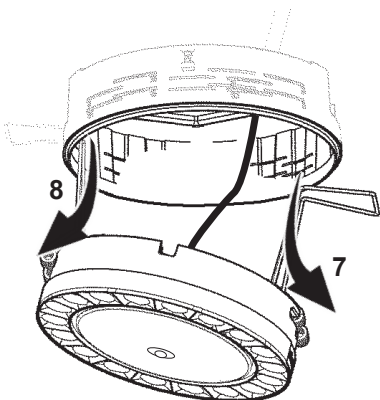
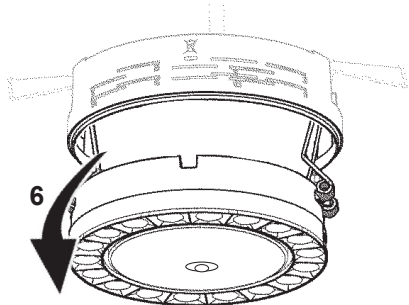
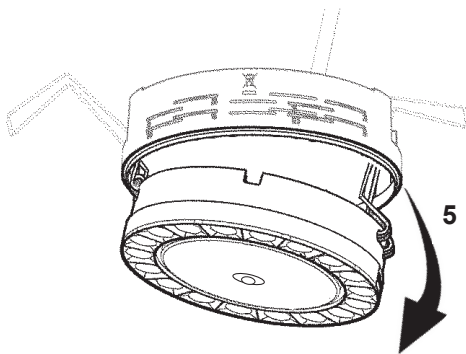
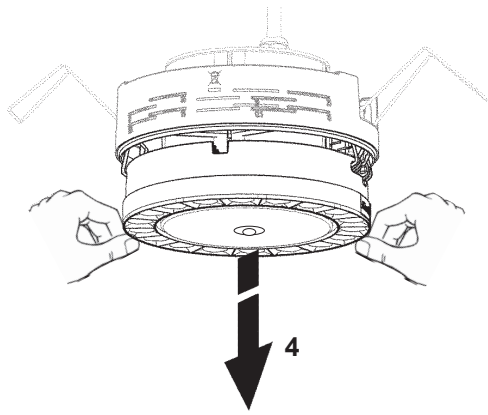



MULTISENSOR BLUETOOTH









App
"iGuzzini Smart Light 2"





<https://qrco.de/bdf6nh>







App
"iGuzzini Smart Light 2"





<https://qrco.de/bdDY75>

 Video tutorial

 O.T.A. UPDATE
(Over the Air)

Integrated Beacon for Smart Services
Protocols: iBeacon, Eddystone, AltBeacon



<https://www.iguzzini.com/smart-services/>

IT Scansionare il codice QR o visitare www.iguzzini.com per ulteriore documentazione tecnica.

EN Scan the QR Code or visit www.iguzzini.com for more technical documentation.

FR Numériser le code QR ou consulter www.iguzzini.com pour davantage de documentation technique.

DE QR-Code scannen oder www.iguzzini.com für weitere technische Unterlagen aufrufen.

NL Escanear el código QR o visitar la página www.iguzzini.com para obtener más documentación técnica.

ES Scan de QR-code of bezoek www.iguzzini.com voor meer technische documentatie.

DA Scan QR-koden eller gå til www.iguzzini.com for yderligere teknisk dokumentation.

NO Skann QR-koden eller besøk www.iguzzini.com for mer teknisk dokumentasjon.

SV Skanna QR-koden eller gå till www.iguzzini.com för ytterligare teknisk dokumentation.

RU Сканируйте QR-код или обратитесь к www.iguzzini.com за дополнительной технической документацией.

ZH 扫描二维码或浏览网站 www.iguzzini.com 获取更多的技术文档。

Bluetooth Low Energy	
Frequency	2,4 GHz
Distance	45m (it varies depending on the installation enviroment)
TX Power	max 8 dBm
Beacon	Integrated
Illuminance Specification	
Range	0 - 2000 lux
Presence detection Specifications	
Mounting height	2.4 - 3 m

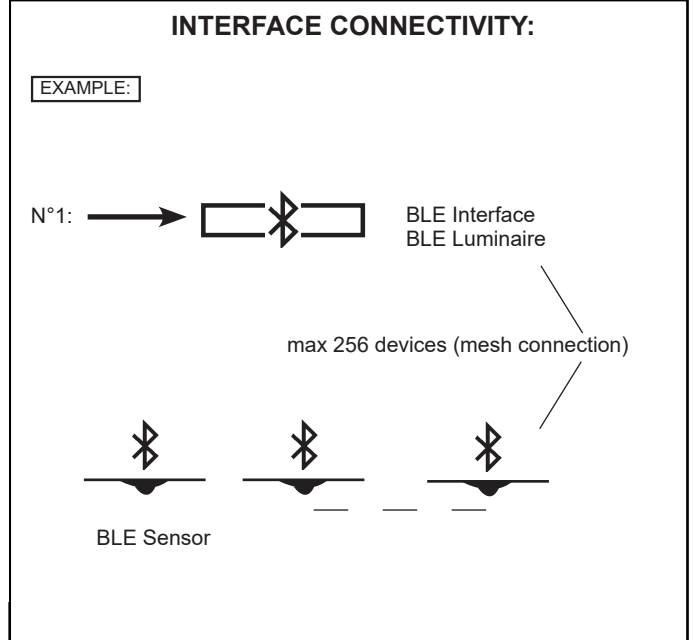

MESH OPERATION

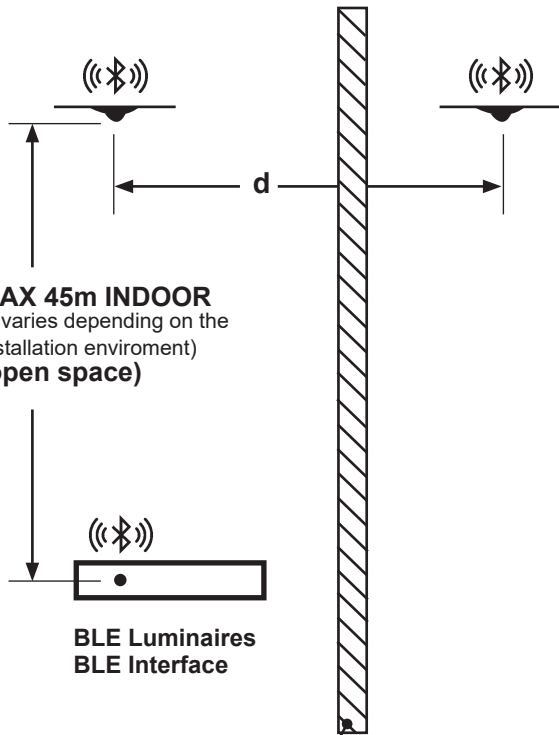

MATERIAL d REDUCTION

Concrete	---	---	---	---
Metal	---	---	---	---
Brick	---	---	---	---
Wood	---	---	---	---
Soil	---	---	---	---
Glass	---	---	---	---

IT La distanza massima dipende anche dalla disposizione nello spazio e dalla presenza di altri segnali wireless. Si raccomanda di verificare l'affidabilità della comunicazione nella posizione di installazione effettiva mediante un semplice mock-up.

EN The maximum distance is influenced also by the space layout and the presence of other wireless signals. It's recommended to test the reliability of the communication at the actual installation site with a simple mock-up.

FR La distance maximale dépend aussi de la disposition de l'espace et de la présence d'autres signaux sans fil. Il est recommandé de s'assurer de la fiabilité de la communication dans la position réelle d'installation avec un simple Cellule Témoin.

DE Die maximale Entfernung hängt auch von der Raumaufteilung und dem Vorhandensein anderer Wireless-Signale ab. Wir empfehlen, die Zuverlässigkeit der Übertragung am tatsächlichen Installationsort mithilfe eines einfachen Mock-up zu testen.

NL De maximumafstand hangt ook af van de ruimte en of andere draadloze signalen aanwezig zijn. Het wordt aanbevolen om de betrouwbaarheid van d communicatie op de daadwerkelijke installatieplek aan de hand van een eenvoudig mock-up.

ES La distancia máxima también depende de la distribución del espacio y de la presencia de otras señales inalámbricas. Se recomienda comprobar la fiabilidad de la comunicación en el punto de instalación real utilizando un simple mock-up.

DA Den maksimale afstand afhænger også af omgivelsernes indretning og af andre tilstedeværende trådløse signaler. Det er vigtigt at kontrollere forbindelsens pålidelighed på det reelle installationssted vha. en enkelt mock-up.

NO Maksimumavstanden påvirkes også av plasslayouten og forekomsten av andre trådløse signaler. Vi anbefaler at du tester påliteligheten til kommunikasjonen på det aktuelle installasjonsstedet med en enkel mock-up.

SV Det maximala avståndet beror också på utrymmets layout och på om det förekommer andra trådlösa signaler. Vi rekommenderar att man testar kommunikationens tillförlitlighet på den faktiska installationsplatsen med hjälp av en enkel mock-up.

RU Максимальное расстояние зависит также от расположения помещения и наличия других беспроводных сигналов. Рекомендуется проверять надежность связи в месте установки при помощи простой Моккап.

ZH 最大距离还受到空间布局和其他无线信号的影响。因此我们建议在实际安装现场先用简单的模型测试通信的可靠性。

App settings:

MOTION SENSOR, DAYLIGHT SENSOR

MANUAL

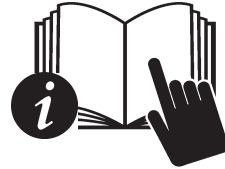

<https://qrco.de/bdDtjG>

PIR Sensor Characteristics

Presence detection coverage

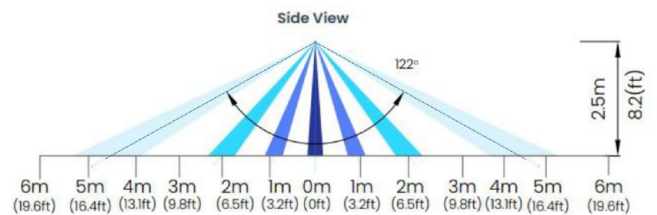

Daylight Sensor Installation Guide

The daylight sensor may be deployed in either open loop or closed loop mode.

The default mode is open loop where the lights vary to compensate for the daylight used in use-cases where the area is exposed to daylight.

The light responds to light sensor in open loop mode as follows:

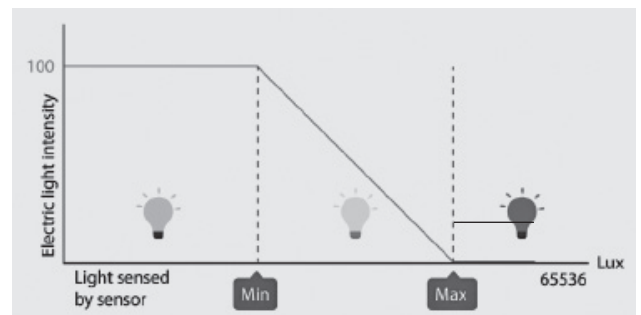

The lights may also be configured in closed loop (maintain ambient light) mode in use-cases where a constant ambient light is to be maintained in an area or surface.

The installation details for each scenario is detailed below. In either case the following should be taken care:

DAYLIGHT DETECTION AREA

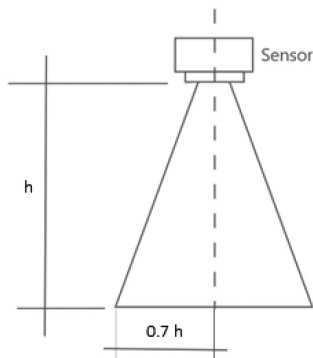

- The sensor must have unobstructed view of the area to be monitored.
- The sensor placed at a height h from the floor, will have sensitivity radially around $0.7h$
- It is advisable to use a separate lux meter to measure light levels at potential locations before choosing the finalizing the sensor placement position.

Sensor Installation Open Loop

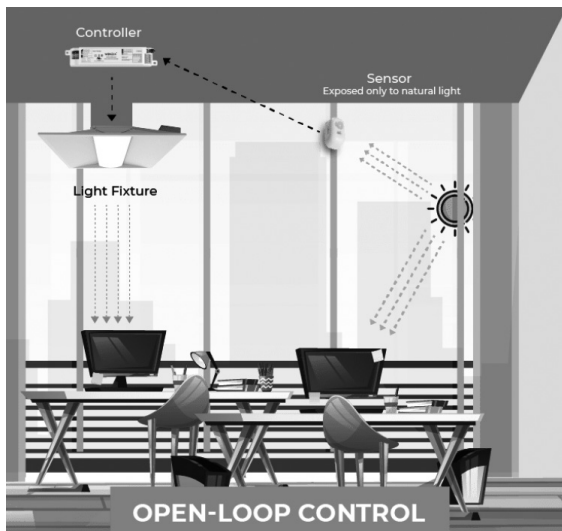

- Position the daylight sensor such that it can measure only the incoming daylight by orienting towards a window or skylight and not the illuminated area that is to be controlled. For best results, the sensor should receive as little electric light as possible.
- By default, the lights will respond with an inverse dimming curve corresponding to the operating range of the daylight sensor (lights will turn off at 100% ambient light and turn on at maximum brightness at 0% ambient light where the percentage of ambient light is calculated based on configured min and max operating range of ambient light sensor)

Closed Loop

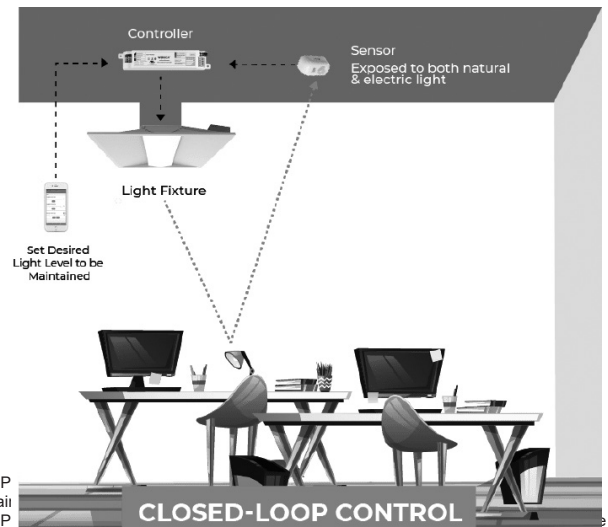

- Position the sensor.
- Set the desired light level to be maintained.
- All the lights to be configured to the ambient level to be maintained at the percentage shown in sensor data log of the sensor at the desired ambient level.

Sensor Calibration

- Collect the daylight sensor readings for 24 hours after commissioning the sensor with the support of a gateway.
- From the sensor readings collected for the past 24 hours, note down the minimum and maximum values
- Go to the Settings page of the sensor and choose the Ambient Light Configuration option
- In the Set New Min Ambient Light field, enter the minimum sensor reading measured. Alternatively, this can be configured at the time when sunlight is lowest in the environment (late evening or early morning).
- In the Set New Max Ambient Light field, enter the maximum sensor reading measured. Alternatively, this can be configured at the time when sunlight is maximum in the environment (at noon).
- The set min and max values define the operating range of the daylight sensor.

IT Il fabbricante/importatore, iGuzzini Illuminazione, dichiara che i prodotti BLE sono conformi alla direttiva 2014/53/UE. Il testo completo della dichiarazione di conformità UE è disponibile al seguente indirizzo Internet: <http://www.iguzzini.com>.

EN The manufacturer/importer, iGuzzini Illuminazione, hereby declares that its BLE products comply with EU regulation 2014/53/UE. The complete EU Declaration of Conformity is available at the following internet address: <http://www.iguzzini.com>.

FR Le fabricant/l'importateur, iGuzzini Illuminazione, déclare que les produits BLE sont conformes à la directive 2014/53/UE. Le texte intégral de la déclaration de conformité UE est disponible à l'adresse Internet <http://www.iguzzini.com>.

DE Der Hersteller/Importeur iGuzzini Illuminazione erklärt, dass die Produkte BLE der Richtlinie 2014/53/EU entsprechen. Der vollständige Wortlaut der EU-Konformitätserklärung kann unter <http://www.iguzzini.com> eingesehen werden.

NL De fabrikant/importeur iGuzzini Illuminazione verklaart dat de producten BLE overeenstemmen met de richtlijn 2014/53/EU. De volledige tekst van de EU-verklaring van overeenstemming is verkrijgbaar op het volgende internetadres: <http://www.iguzzini.com>

ES El fabricante/importador, iGuzzini Illuminazione, declara que los productos BLE son conformes con la directiva 2014/53/UE. El texto completo de la declaración de conformidad UE se puede consultar en la siguiente dirección de Internet: <http://www.iguzzini.com>.

DA Fabrikanten/importøren, iGuzzini Illuminazione (iGuzzini Belysning) erklærer, at BLE-produkterne stemmer overens med direktiv 2014/53/EU. EU-overensstemmelseserklæringens fulde tekst står til rådighed på den følgende Internetadresse: <http://www.iguzzini.com>

NO Produsenten/importøren, iGuzzini Illuminazione, erklærer at produktene BLE er i samsvar med direktivet 2014/53/EU. Den fullstendige teksten til samsvarserklæringen er tilgjengelig på følgende internetadresse: <http://www.iguzzini.com>

SV Tillverkaren/importören, iGuzzini Illuminazione, försäkrar att nedanstående BLE-produkter är överensstämmande med direktiv 2014/53/EU. Den fullständiga texten i EU-försäkran om överensstämmelse finns tillgänglig på följande Internetadress : <http://www.iguzzini.com>

RU Изготовитель/импортер iGuzzini Illuminazione заявляет, что изделия BLE отвечают требованиям директивы 2014/53/UE. С полным текстом Декларации соответствия ЕС можно ознакомиться по следующему адресу в Интернете: <http://www.iguzzini.com>

ZH 制造商/进口商 iGuzzini Illuminazione 照明公司声明产品 BLE 符合指令 2014/53/UE 的要求。欧盟符合性声明的完整内容可到以下网址查阅 : <http://www.iguzzini.com>