

**X899**

2.510.312.01 IS18923/02

**iGuzzini**

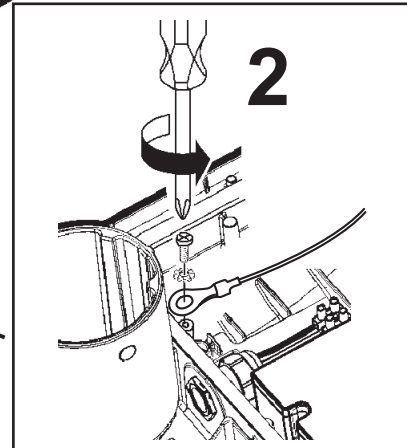
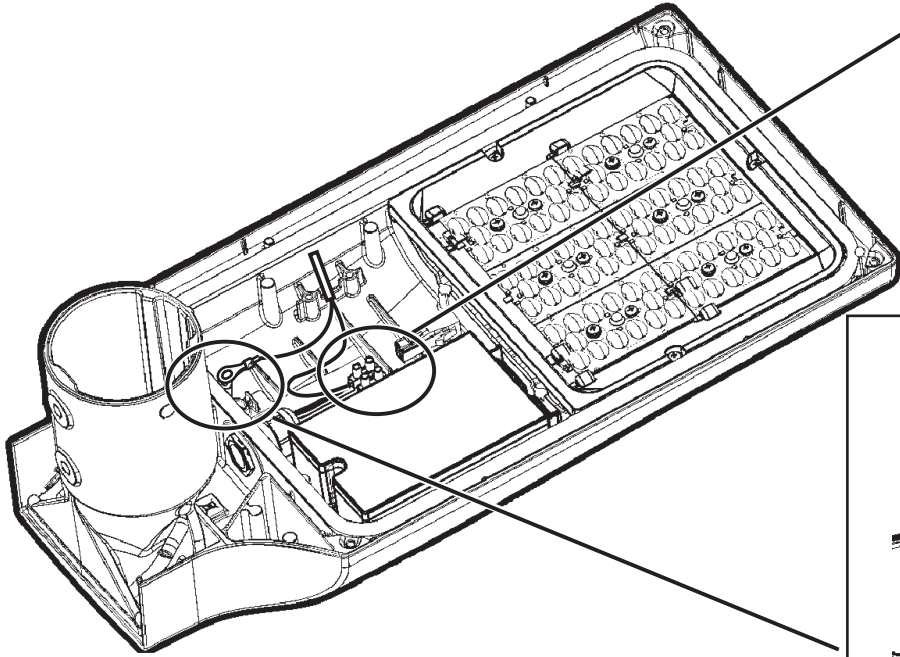
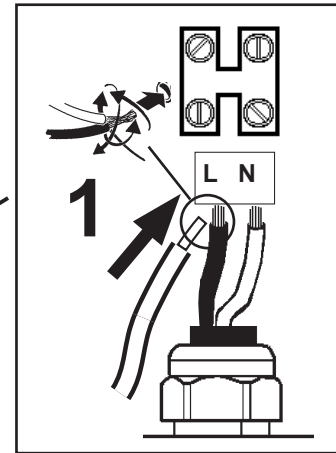
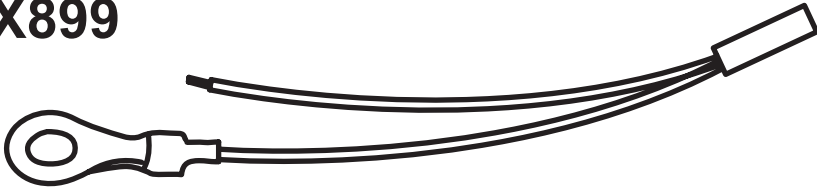

**X899**

2.510.312.01 IS18923/02

**iGuzzini**

