

PALCO SURFACE (remote driver)

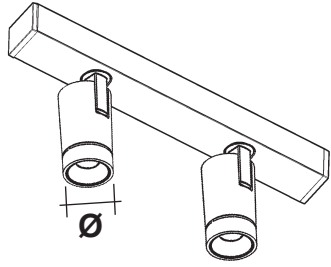

Ø	PRODUCT	ART
19 mm		QC34 - QC35 - QX23
2x19 mm		QC36 - QC37 - QX24
3x19 mm		QC38 - QC39 - QX25
37 mm		QC40 - QC41 - QC42 QC43 - QX26 - QX27
2x37 mm		QC44 - QC45 - QX28
3x37mm		QC46 - QC47 - QX29
51 mm		QC48 - QC49 - QC50 QC51 - QX30 - QX31
2x51 mm		QC52 - QC53 - QX32
3x51mm		QC54 - QC55 - QX33

IT ATTENZIONE:

LA SICUREZZA DELL'APPARECCHIO E' GARANTITA SOLO CON L'USO APPROPRIATO DELLE SEGUENTI ISTRUZIONI; PERTANTO E' NECESSARIO CONSERVARLE.

EN WARNING:

THE SAFETY OF THIS FIXTURE IS GUARANTEED ONLY IF YOU COMPLY WITH THESE INSTRUCTIONS; REMEMBER TO CONSERVE IN A SAFE PLACE.

FR ATTENTION:

LA SECURITE DE L'APPAREIL N'EST GARANTIE QU'EN CAS D'UTILISATION CORRECTE DES INSTRUCTIONS SUIVANTES; IL FAUT PAR CONSEQUENT LES CONSERVER.

DE ACHTUNG:

DIE SICHERHEIT DES GERÄTES WIRD NUR DURCH SACHGEMÄSSE BEFOLGUNG NACHSTEHENDER ANWEISUNGEN GEWÄHRLEISTET; IHRE AUFBEWAHRUNG IST DESHALB SEHR WICHTIG.

NL OPGELET:

DE VEILIGHEID VAN DI ATOESTEL IS SLECHTS DAN GEGARANDEERD ALS INDIEN DE VOLGENDE INSTRUCTIES STRIKT WORDEN TOEGEPAST. DAAROM MOET MEN ZE OOK BEWAREN.

ES ATENCION:

LA SEGURIDAD DEL APARATO SE GARANTIZA SOLO CUMPLIENDO CUIDADOSAMENTE LAS SIGUIENTES INSTRUCCIONES; POR ELLO, ES NECESARIO CONSERVARLAS.

DA BEMÆRK:

SIKKERHEDEN VED BRUG AF ARMATURET KAN KUN GARANTERES, HVIS DISSE ANVISNINGER FØLGES; SØRG DERFOR FOR AT GEMME DEM.

NO ADVARSEL:

SIKKERHETEN TIL DETTE APPARATET GARANTERES KUN HVIS DU OVERHOLDER DISSE INSTRUKSJONENE; HUSK Å OPPBEVARE DEM PÅ ET TRYGT STED.

SV OBSERVERA!

UTRUSTNINGENS SÄKERHET KAN ENDAST GARANTERAS OM DESSA ANVISNINGAR RESPEKTERAS I DETALJ. SPARA DÄRFÖR DESSA ANVISNINGAR FÖR FRAMTIDA KONSULTATION.

RU ВНИМАНИЕ:

МЫ ГАРАНТИРУЕМ БЕЗОПАСНУЮ ЭКСПЛУАТАЦИЮ ИЗДЕЛИЯ ТОЛЬКО ПРИ СОБЛЮДЕНИИ СЛЕДУЮЩИХ ИНСТРУКЦИЙ; С ЭТОЙ ЦЕЛЬЮ НЕОБХОДИМО СОХРАНИТЬ ДАННУЮ БРОШЮРУ.

ZH 警告

为确保该装置安全，请遵守操作指示；并于安全场所放置。

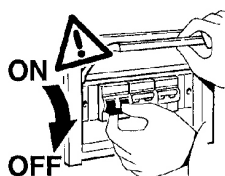

IT N.B.: DURANTE L'INSTALLAZIONE DEL SISTEMA RISPETTARE SCRUPolosAMENTE LE NORME IMPIANTISTICHE VIGENTI.

EN N.B.: WHEN INSTALLING THE SYSTEM, STRICTLY COMPLY WITH ALL REGULATIONS ON INSTALLATION IN FORCE.

FR N.B.: LORS DE L'INSTALLATION DU SYSTÈME VEUILLEZ RESPECTER RIGOREUSEMENT LES NORMES EN VIGUEUR EN LA MATIÈRE.

DE NB.: BEACHTEN SIE BEI DER INSTALLATION DES SYSTEMS GEWISSENHAFT DIE GÜLTIGEN BESTIMMUNGEN BEZÜGLICH DER ANLAGENTECHNIK.

NL N.B.: BIJ HET INSTALLEREN VAN HET SYSTEEM MOET U DE GELDEN DE INSTALLATIENORMEN STRIKT NALEVEN.

ES N.B.: DURANTE LA INSTALACIÓN DEL SISTEMA RESPETAR E SCRUPolosAMENTE LAS NORMAS DE INSTALACIÓN VIGENTES.

DA N.B.: UNDER INSTALLATION AF SYSTEMET SKAL MAN NØJE OVERHOLDE DE GÆLDENDE REGLER FOR DISSE ANLÆG.

NO N.B.: VED INSTALLASJON AV SYSTEMET SKAL ALLE FORSKRIFTER OM INSTALLASJON SOM GJELDER FØLGES STRENGT.

SV OBS! UNDER INSTALLATIONEN AV SYSTEMET SKA INSTALLATIONSFÖRESKRIFTERNA RESPEKTERAS I DETALJ.

RU ПРИМЕЧАНИЕ: В ПРОЦЕССЕ МОНТАЖА СИСТЕМЫ СТРОГО СОБЛЮДАЙТЕ НАЦИОНАЛЬНЫЕ ДЕЙСТВУЮЩИЕ НОРМАТИВЫ ПО ЭЛЕКТРОПРОВОДКЕ.

ZH 注意：在安装系统时请遵守设备的安装规定。

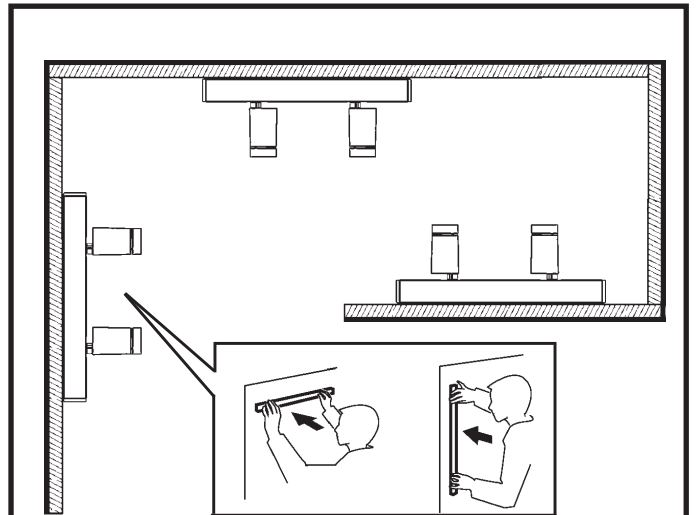
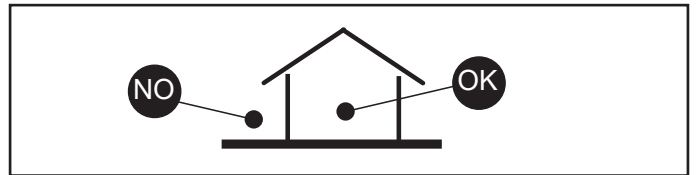

IT Per le posizioni di installazione, attenersi a quelle illustrate, eventualmente contattare la iGuzzini.

EN All installation positions must comply with those illustrated. In the event of any doubt, contact iGuzzini.

FR Pour les positions d'installation, se conformer aux positions illustrées ; contacter la société iGuzzini en cas de nécessité.

DE Für die Einbaupositionen die Abbildungen beachten. Eventuell iGuzzini kontaktieren.

NL Houd u voor de installatieposities aan degene die zijn weergegeven. Neem eventueel contact op met iGuzzini.

ES Respetar las posiciones de instalación ilustradas y, en caso de duda, contactar con iGuzzini.

DA For installationspositioner skal man holde sig til de viste, og eventuelt kontakte iGuzzini.

NO For installasjonsplasseringene henviser vi til illustrasjonene, eller ta eventuelt kontakt med iGuzzini.

SV Följ de angivna positionerna för installationen. Kontakta vid behov iGuzzini.

RU При выборе положения для монтажа следует обратиться к проиллюстрированным либо обратиться в компанию iGuzzini.

ZH 安装位置请参考图示，必要时也可联系iGuzzini。

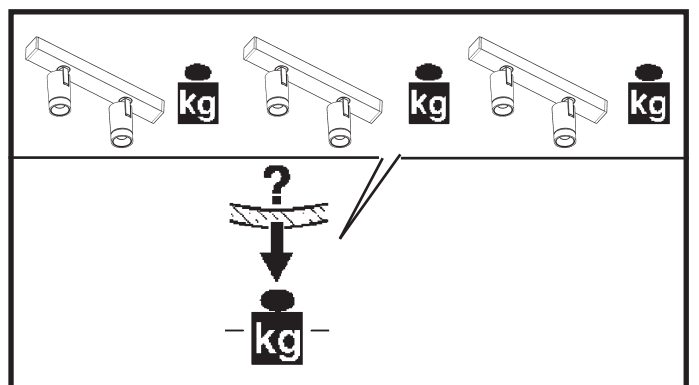

IT DA INSTALLARE SOLO AL DI FUORI DEL VOLUME DI ACCESSIBILITA'
 EN TO BE INSTALLED ONLY OUTSIDE THE ACCESSIBLE SPACE
 FR À INSTALLER UNIQUEMENT EN DEHORS DU VOLUME D'ACCESSIBILITÉ
 DE DAS GERÄT MUSS AUSSERHALB DER REICHWEITE DES ANWENDERS INSTALLIERT WERDEN.
 NL PARA INSTALAR SÓLO FUERA DEL VOLUMEN DE ACCESIBILIDAD
 ES ALLEEN TE INSTALLEREN BUITEN HET TOEGANKELIJKHEIDSGEBIED
 NO MÅ KUN INSTALLERES UDEN FOR ADGANGSOMFANGET
 DA MÅ KUN INSTALLERES UTENFOR TILGJENGELIGHETSOMRÅDET
 SV SKA ENDAST INSTALLERAS UTANFÖR ÅTKOMSTVOLYMEN
 RU ПРОИЗВОДИТЬ МОНТАЖ ТОЛЬКО ЗА ПРЕДЕЛАМИ ДОСТУПНОГО ПРОСТРАНСТВА
 ZH 只可安装于可用空间外侧

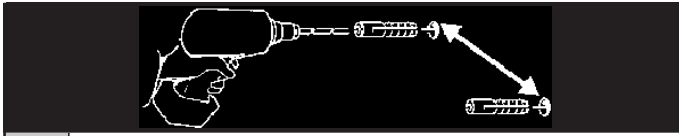

1x

ALIMENTAZIONE
 POWER SUPPLY
 ALIMENTATION
 EINSPEISUNG
 STROOMVERZORGING
 ALIMENTACION
 STRØMFORSYNING
 STRØMFORSYNING
 ELFÖRSÖRJNING
 ЭЛЕКТРОПИТАНИЕ
 电源

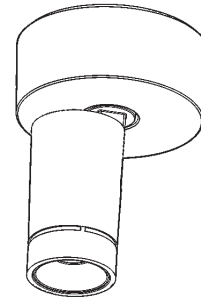
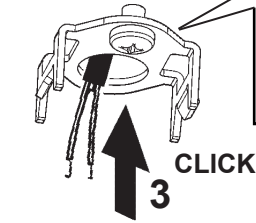
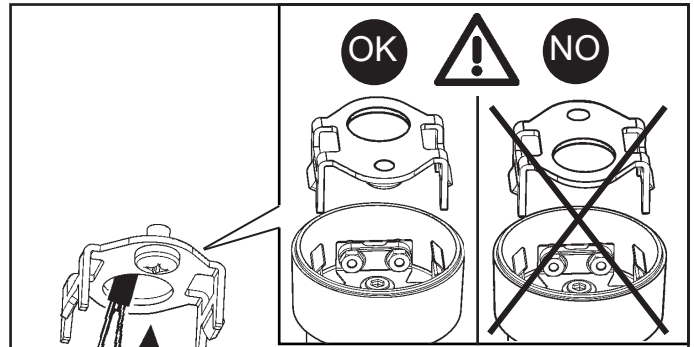
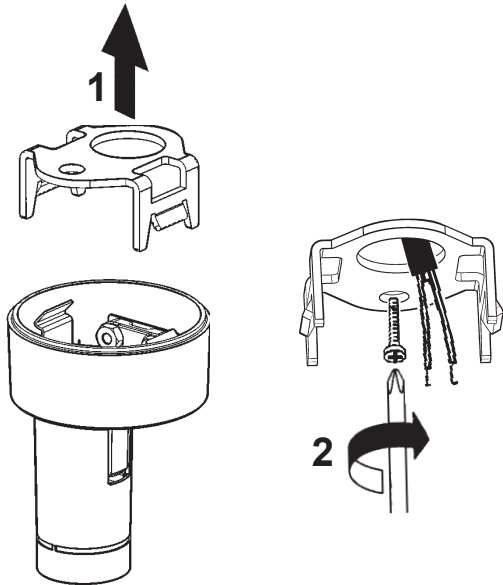
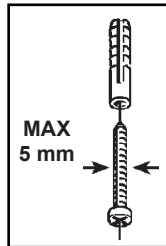
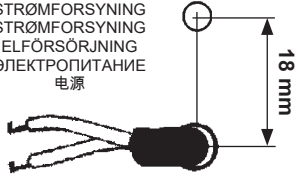

2x

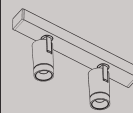

3x

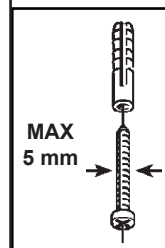
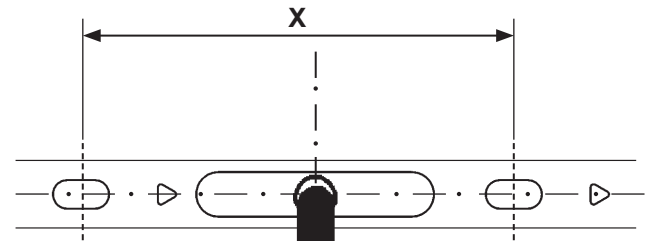
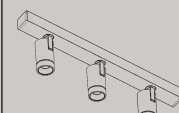

ALIMENTAZIONE
 POWER SUPPLY
 ALIMENTATION
 EINSPEISUNG
 STROOMVERZORGING
 ALIMENTACION
 STRØMFORSYNING
 STRØMFORSYNING
 ELFÖRSÖRJNING
 ЭЛЕКТРОПИТАНИЕ
 电源



ART.	QC36 - QC37 QX24	QC38 - QC39 QX25	QC44 - QC45 QC52 - QC53 QX28 - QX32	QC46 - QC47 QC54 - QC55 QX29 - QX33
X (mm)	78	140	210	350

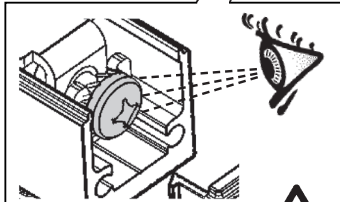
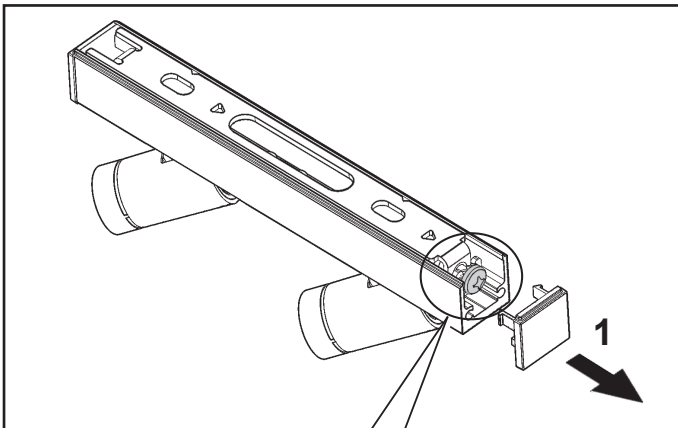

2 Allentare - Loosen
 Desserrez - Lockern Sie
 Draai los - Afloje
 Løsne - Løsnes
 Skruva loss - Ослабить - 松开

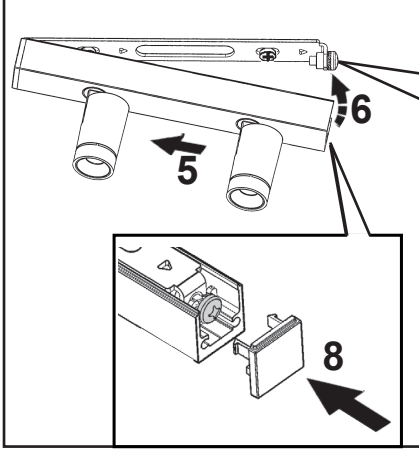
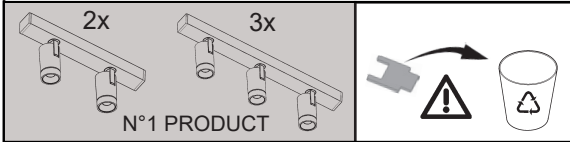
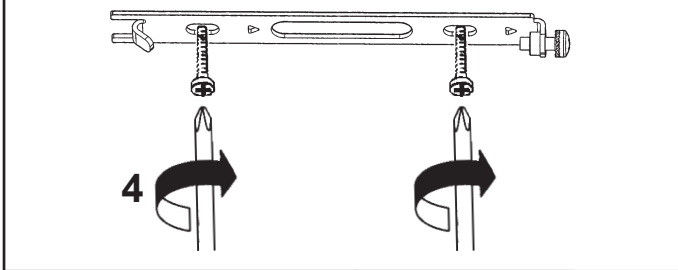
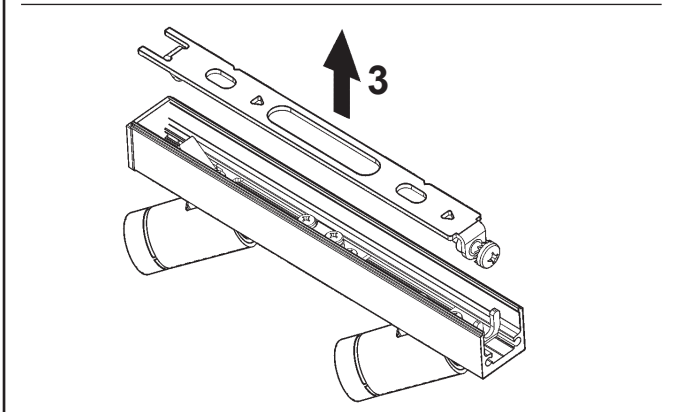

7 Avvitare fino in fondo - Completely tighten
 Visser à fond - Fest anziehen
 Helemaal aanschroeven - Enroscar hasta el fondo
 Skru i bund - Trekk helt til
 Skruva fast till botten
 Закрутить до упора
 把螺丝钉完全拧紧

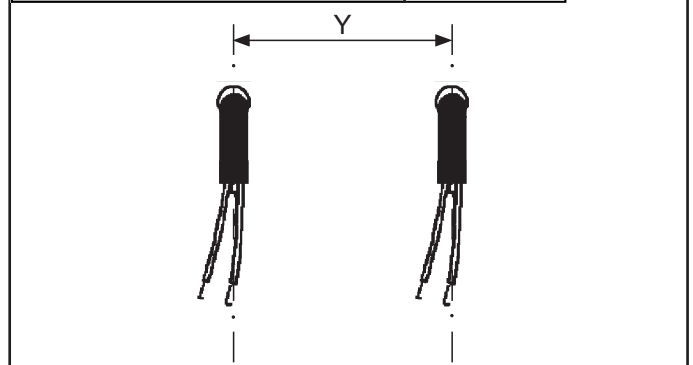
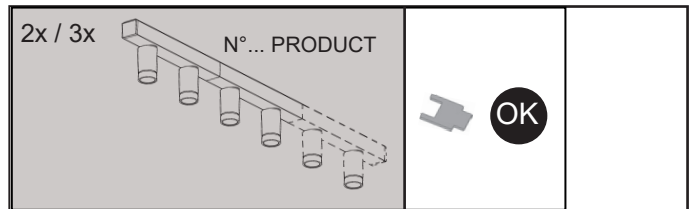
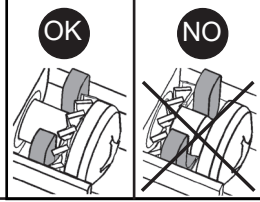

	Ø (mm)	(2x + 2x)	(3x + 3x)	(2x + 3x)
Y (mm)	19	144	216	180
	37 51	284	426	355

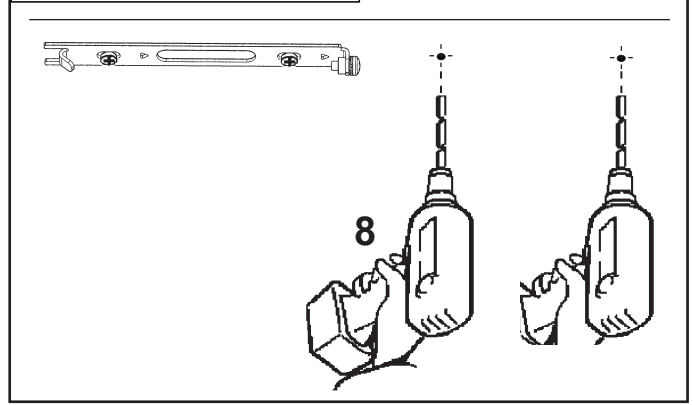
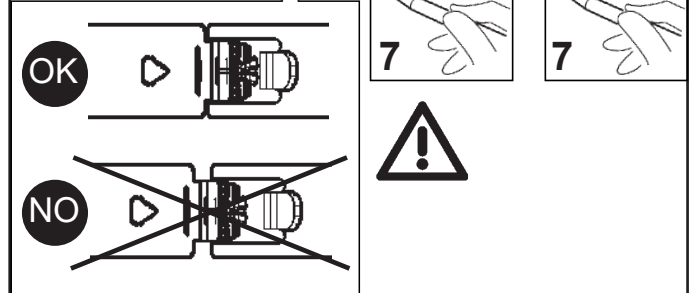
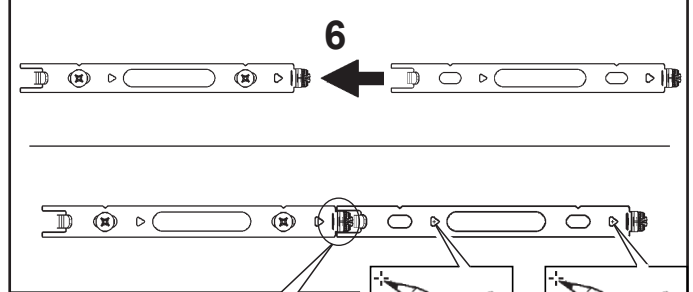
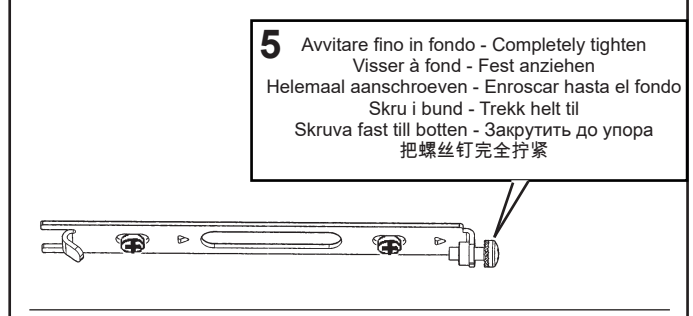

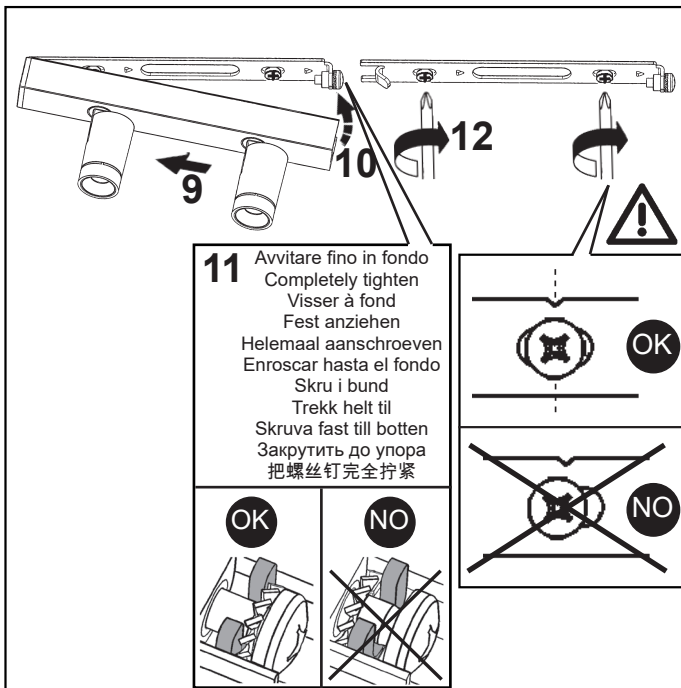

11 Avvitare fino in fondo
Completely tighten
Visser à fond
Fest anziehen
Helemaal aanschroeven
Enroscar hasta el fondo
Skrú i bund
Trek helt til
Skrúva fast till botten
Закрутить до упора
把螺丝钉完全拧紧

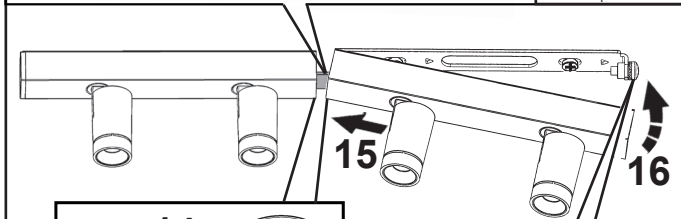
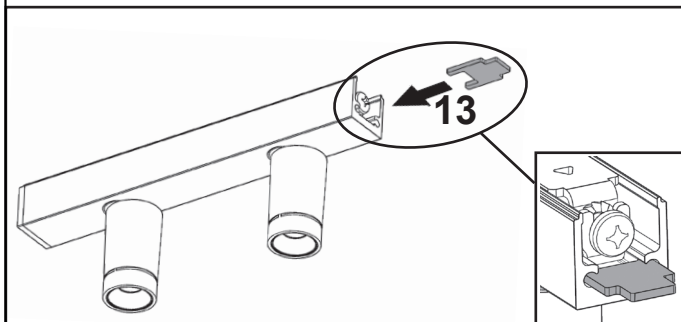
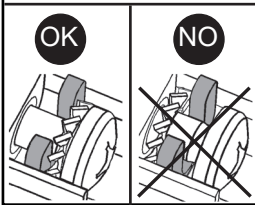

17 Avvitare fino in fondo
Completely tighten
Visser à fond
Fest anziehen
Helemaal aanschroeven
Enroscar hasta el fondo
Skrú i bund
Trek helt til
Skrúva fast till botten
Закрутить до упора
把螺丝钉完全拧紧

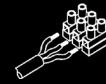
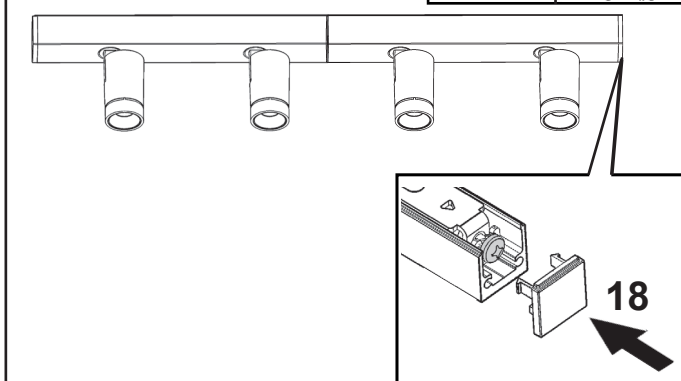
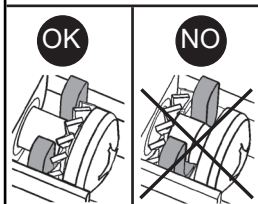

IT Le prestazioni e la sicurezza dell'apparecchio sono garantite soltanto per oscillazioni della corrente del $\pm 5\%$ rispetto al valore nominale.
La conformità alla norma è garantita soltanto utilizzando gruppi driver iGuzzini (art.: PD41 - KC55 - PA19 - BZM4 - MZ84 - X020 - MY83).
Nel caso di utilizzo di driver diversi, per tutte le informazioni tecniche aggiuntive, contattare la iGuzzini

EN The performance level and safety of the lighting fixture are only guaranteed for oscillations of $\pm 5\%$ in the current, in relation to the nominal value.
Conformity with the standard is guaranteed only if iGuzzini driver assemblies (item code PD41 - KC55 - PA19 - BZM4 - MZ84 - X020 - MY83) are used.
When using other drivers, contact iGuzzini for any additional technical information

FR Les performances et la sécurité de l'appareil ne sont assurées que pour des oscillations de courant de $\pm 5\%$ par rapport à la valeur nominale.
La conformité à la norme n'est assurée qu'en cas d'utilisation de blocs drivers iGuzzini (Art.: PD41 - KC55 - PA19 - BZM4 - MZ84 - X020 - MY83).
Si vous utilisez des drivers différents, pour toute information technique supplémentaire, veuillez contacter iGuzzini

DE Die Leistungen und die Sicherheit des Geräts sind nur für vom Vorschaltgerät abgehende Spannungsschwankungen von $\pm 5\%$ in Bezug auf den Nennwert gewährleistet.
Die Übereinstimmung mit der Vorschrift ist nur mit dem Einsatz von iGuzzini-Drivergruppen (Art.: PD41 - KC55 - PA19 - BZM4 - MZ84 - X020 - MY83) gewährleistet.
Werden andere Treiber verwendet, ist für sämtliche zusätzlichen technischen Informationen iGuzzini zu Rate zu ziehen.

NL De prestaties en de veiligheid van het apparaat zijn alleen gegarandeerd voor spanningsvariaties van $\pm 5\%$ ten opzichte van de nominale waarde.
De conformiteit aan de norm wordt alleen gegarandeerd als u iGuzzini driver groepen gebruikt (art.: PD41 - KC55 - PA19 - BZM4 - MZ84 - X020 - MY83).
En caso de utilización de drivers diferentes, para conocer la información técnica adicional ponerse en contacto con iGuzzini

ES Las prestaciones y la seguridad del aparato están garantizada solamente con oscilaciones de la corriente del $\pm 5\%$ respecto al valor nominal.
La conformidad a la norma se garantiza solamente con el uso de alimentadores iGuzzini (art. PD41 - KC55 - PA19 - BZM4 - MZ84 - X020 - MY83) o equivalentes de tipo SELV que cumplen las normas vigentes C.E.I.

DA Armaturets ydelse og sikkerhed kan kun garanteres ved strømsvingning på $\pm 5\%$ i forhold til den nominelle værdi.
Opfyldelse af reglerne garanteres kun ved brug af strømforsyningsenheder fra iGuzzini (art.: PD41 - KC55 - PA19 - BZM4 - MZ84 - X020 - MY83) eller tilsvarende af typen SELV, der opfylder kravene i C.E.I.-standarderne.

NO Ytelsesnivået og sikkerheten til lysarmaturen kan kun garanteres for svingninger på $\pm 5\%$ i strømmen, i forhold til nominell verdi.
Samsvar med forskriften garanteres bare ved bruk av transformatorer fra iGuzzini (art.: PD41 - KC55 - PA19 - BZM4 - MZ84 - X020 - MY83) eller tilsvarende av typen SELV som tilsvarer gjeldende forskrifter C.E.I.

SV Utrustningens prestanda och säkerhet garanteras endast vid en strömsvängning på $\pm 5\%$ i förhållande till nominellt värde.
Överensstämmelse med standard garanteras endast genom att använda nättaggregat av typ iGuzzini (art.: PD41 - KC55 - PA19 - BZM4 - MZ84 - X020 - MY83) eller motsvarande av typ SELV som överensstämmer med gällande C.E.I.-standard.

RU Эксплуатационные качества и безопасность прибора гарантируются только при колебаниях тока $\pm 5\%$ от номинального значения.
Соответствие нормативу гарантируется только при использовании драйверов iGuzzini (арт.: PD41 - KC55 - PA19 - BZM4 - MZ84 - X020 - MY83) или аналогичных типа SELV, отвечающих нормам ЕЭС.

ZH 只有在电流的额定值 $\pm 5\%$ 的情况下，才可以保证装置的使用性能及安全性
只有在使用IGUZZINI的供电单元（PD41-KC55-PA19-BZM4-MZ84-X020-MY83产品）或者与之相同的SELV种类的符合C.E.I.法规的供电单元情况下，产品的合格性才能被保证

IT L'unità di alimentazione esterna deve essere SELV.

EN The external power supply unit must be SELV.

FR L'unité d'alimentation externe doit être de type SELV.

DE Die externe Versorgungseinheit muss SELV mit.

NL De externe voedingseenheid moet een SELV-apparaat zijn.

ES La unidad de alimentación exterior ha de ser SELV.

DA Den eksterne forsyningsenhed skal være SELV.

NO Den eksterne strømforsyningsenheten skal være SELV.

SV Den externa matningsenheten ska vara av typen SELV.

RU Внешний блок питания должен быть типа SELV с выходным напряжением

ZH 外部电源设备应为安全超低电压SELV。

IT Cablare alla rete elettrica l'alimentatore solo dopo aver effettuato il collegamento ai prodotti

EN Wire the ballast to the power supply network only once it has been connected to the products

FR N'effectuer le câblage du ballast au réseau électrique qu'après avoir effectué le raccordement aux produits

DE Schließen Sie das Vorschaltgerät erst nach der Verdrahtung an den Produkten am Stromnetz an.

ES Cablear el alimentador a la red eléctrica sólo después de realizar la conexión de los productos.
NL Verbind het voorschakelapparaat alleen aan op het elektriciteitsnet nadat u alle producten heeft aangesloten.

DA Tilslut først strømforsyningsenheden til strømforsyningsnettet, efter at have foretaget tilslutningen til produkterne.

NO Kable transformatoren til el-nettet bare etter at produktene er tilkoblet

SV Anslut strømforsörjningsanordningen till elnätet först efter att anslutningen till produkterna har utförts.

RU Подсоединить к электросети блок питания только после подсоединения к приборам.

ZH 仅在镇流器连接到产品的时候才将其连接至电源网络

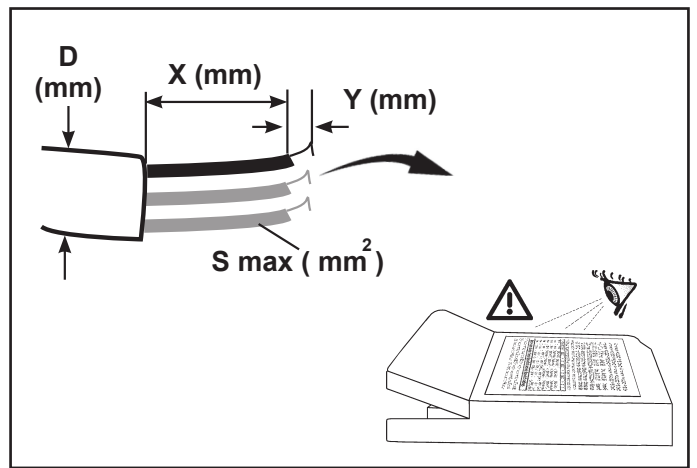
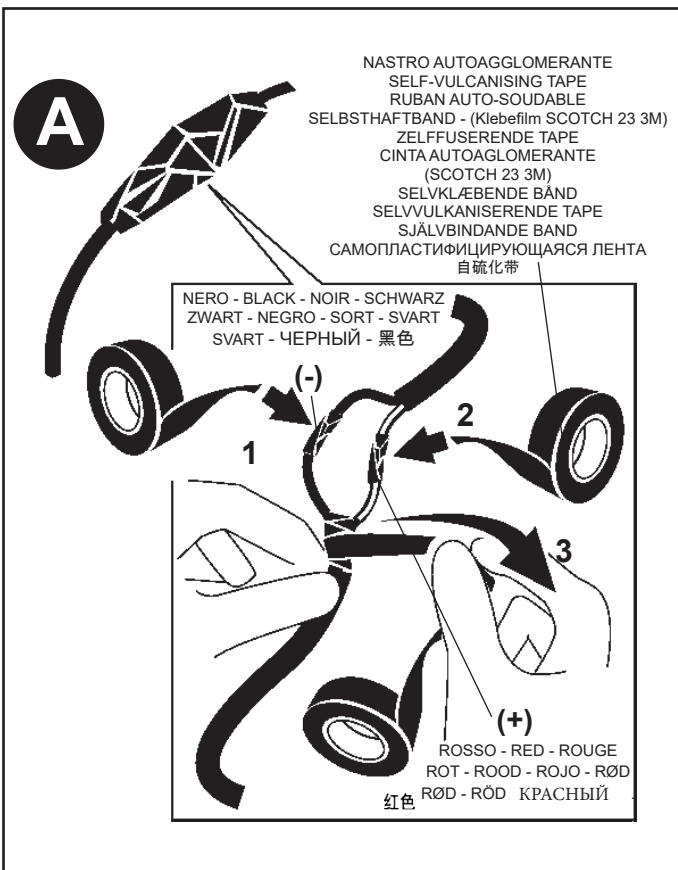
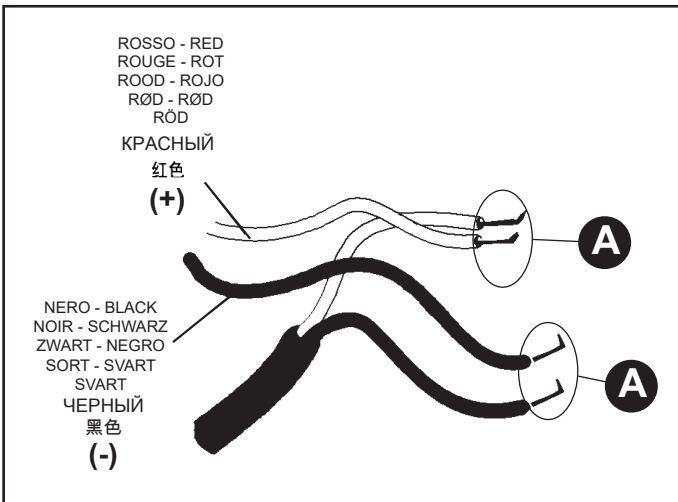
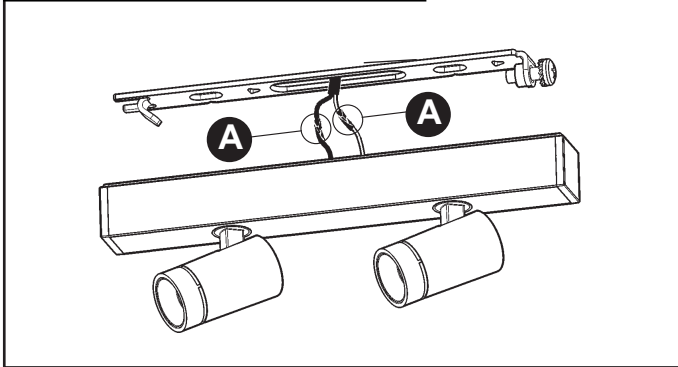

	S mm ²	Y mm	X mm	D mm
TCI - UNIVERSALE	0,5 - 1,5	8,5 - 9,5	30	3 - 8
PRO FLAT	0,75 - 1,5	8,5 - 9,5	30	3 - 10
DC JOLLY DALI - DC JOLLY US	0,75 - 1,5	8,5 - 9,5	30	3 - 8
TCI - DC MAXI JOLLY US	0,5 - 2,5	/	30	3 - 8
TCI - DC MAXI JOLLY US DALI				
TCI - MP 50 K3				

DALI VERSION Art. PA19 - BZM4

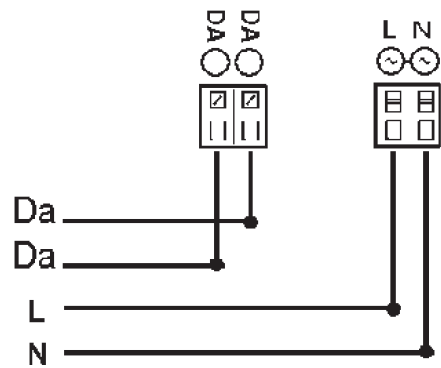

PUSH DIM Art. KC55 - MY83 -BZM4

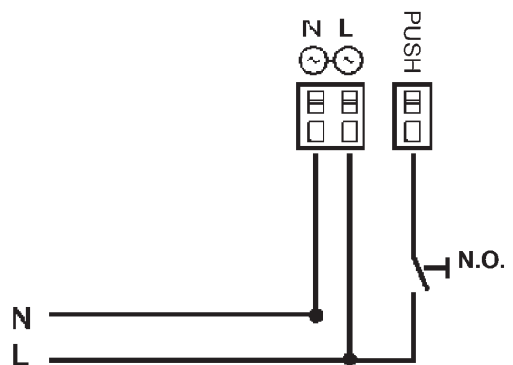

Art. KC55 - MY83 -BZM4

IT I dispositivi con cablaggio digitale possono essere dimmerati con dispositivi DALI o con pulsante normalmente aperto (N.O.) da collegare come da schema.

EN Devices with digital control gear may be dimmed using DALI devices or a normally-open button (N.O.) to be connected as shown in the diagram.

FR Les articles à câblage numérique peuvent fonctionner avec des variateurs à dispositifs DALI ou à bouton poussoir normalement ouvert (N.O.) à relier conformément au schéma.

DE Die Geräte mit digitaler Verkabelung können mit Hilfe von DALI-Vorrichtungen oder mit Hilfe eines gemäß Schaltplan anzuschließenden Schließers (N.O.) gedimmt werden.

NL De producten met digitale bekabeling kunnen worden gedimd met DALI systemen of met een N.O. (normally open) knop, die moet worden aangesloten volgens schema.

ES Los dispositivos con cableado digital pueden regularse con dispositivos DALI o con un interruptor de botón normalmente abierto (N.O.) que se conecta según ilustrado en el esquema.

DA Produkter med digital kabelføring kan dæmpes med DALI-anordninger eller med kontakten, som normalt er åben (N.O.) og som skal tilsluttes, som vist.

NO Produkter med digitalkabler kan dimmes med DALI-anordninger eller med en normalt åpen (NO) trykkbryter som kobles som vist i koblingskjema.

SV Produkter med digital kabeldragning kan föräms med dimmer. Detta kan göras med DALI-anordningarna eller med en normalt öppen kontakt (N.O.) som ska anslutas enligt schemat.

RU Интенсивность приборов с цифровой проводкой может регулироваться посредством устройств DALI или нормально разомкнутой кнопкой (Н.Р.), подсоединяемой согласно схеме.

ZH 带有数字控制装置的设备可以通过 DALI (数字化可寻址调光接口) 设备或者一个连接方式如图中所示的常开按钮 (N.O.) 进行亮度调节

IT Pilotare diversi prodotti DALI tramite pulsante (es: Touch-dim, Switch-dim, Push-dim, Direct-dim, etc.) potrebbe causare dei problemi di sincronizzazione tra gli stessi. È possibile ovviare a questo problema dotandosi di dispositivi aggiuntivi. Per maggiori informazioni vi invitiamo a contattarci direttamente.

EN Controlling different DALI products through buttons (e.g.: Touch-dim, Switch-dim, Push-dim, Direct-dim, etc.) may lead to product synchronisation problems. This problem can be overcome by using additional devices. For further information, please contact us directly.

FR Piloter plusieurs produits DALI par bouton (ex : Touch-dim, Switch-dim, Push-dim, Direct-dim, etc.) pourrait causer des problèmes de synchronisation entre eux. Ce problème peut être évité en s'équipant de dispositifs supplémentaires. Pour de plus amples renseignements, veuillez nous contacter directement.

DE Die Steuerung verschiedener DALI-Produkte mittels Taste (z.B.: Touch-dim, Switch-dim, Push-dim, Direct-dim etc.) kann eventuell zu Synchronisierungsproblemen zwischen diesen führen. Dieses Problem lässt sich durch den Einsatz von zusätzlichen Geräten beheben. Wenn Sie weitere Informationen wünschen, setzen Sie sich bitte direkt mit uns in Verbindung.

NL Het besturen van verschillende DALI producten m.b.v. dezelfde knop (bv.: Touch-dim, Switch-dim, Push-dim, Direct-dim, etc.) kan synchronisatieproblemen tussen de producten opleveren. Men kan dit probleem voorkomen door extra systemen aan te sluiten. Voor verdere informatie raden we u aan direct contact met ons op te nemen.

ES El mando de varios productos DALI por tecla (ej: Touch-dim, Switch-dim, Push-dim, Direct-dim, etc.) podría causar problemas de sincronización entre ellos. Es posible prevenir este problema utilizando dispositivos adicionales. Para más información, contacte directamente con nosotros.

DA Hvis DALI-produkterne styres ved hjælp af knapperne (fx. Touch-dim, Switch-dim, Push-dim, Direct-dim osv.), kan det skabe problemer med synkronisering af samme. Dette problem kan undgås, hvis man køber ekstra enheder. For yderligere oplysninger, kontakt os direkte.

NO Å styre ulike DALI-produkter ved hjelp av en trykknappbryter (f.eks. touch-dim, switch-dim, push-dim, direct-dim, osv.) vil kunne føre til problemer med synkroniseringen mellom dem. Dette problemet kan løses ved hjelp av noen tilleggsinnretninger. Ta gjerne kontakt med oss for mer informasjon om dette.

SV Styrning av olika DALI-produkter med knapp (t.ex.: Touch-dim, Switch-dim, Push-dim, Direct-dim o.s.v.) kan orsaka synkroniseringsproblem mellan dessa. Detta problem kan åtgärdas med tillägsanordningar. För mer information kan du kontakta oss direkt.

RU Управление различными продуктами DALI с помощью кнопки (напр.: Touch-dim, Switch-dim, Push-dim, Direct-dim и пр.) может вызвать проблемы синхронизации между ними. Эту проблему можно устранить путем задействования дополнительных устройств. За получением более подробной информации просим Вас связаться с нами непосредственно.

ZH 通过按钮控制不同的 DALI 产品 (例如: 触摸调光、切换调光、按压调光、直接调光等) 可能会导致产品的同步问题。该问题可通过使用其他额外的装置加以克服。如需了解更多信息, 请直接与我们联系。

IT Tra i conduttori di alimentazione e quelli di controllo è garantito un isolamento doppio.

EN Insulation is guaranteed between the power supply wires and the control wires double.

FR Entre les conducteurs d'alimentation et les conducteurs de commande, une isolation est garantie double.

DE Zwischen den Versorgungs- und Steuerungsleitern ist eine Isolierung Doppelisolierung gewährleistet.

NL Tussen de geleiders van de voeding en de controle wordt een isolatie gewaarborgd dubbel.

ES Entre los conductores de alimentación y los de control está garantizado el aislamiento doble.

DA Der er garanteret en isolering dobbelt imellem forsyningslederne og styrelederne.

NO Det garanteres en isolering dobbelt mellom strømliderne og kontrolliderne.

SV Det garanteras isolering dubbel mellan matningsledare och kontrollkablar.

RU Гарантируется развязка цепей питания и управления двойная.

ZH 电源线和控制线之间有绝缘保证双重。

CARICO DALI / DALI LOAD CHARGE DALI (COURANT MAXI ADMISSIBLE) DALI-LAST DALI VERMOGEN CARGA DALI DALI STRØMSTYRKE BELASTNING FOR "DALI" DALI-BELASTNING МАКС. ТОК СИСТЕМЫ DALI С РЕГУЛЯЦИЕЙ ИНТЕНСИВНОСТИ СВЕТА DALI 智能调光系统允许的最大电流量	INDIRIZZI DALI DALI ADDRESSES ADDRESSES DALI DALI-ADRESSEN DALI-ADRESSEN DIRECCIONES DALI DALI ADDRESSER ADDRESSER TIL "DALI" DALI-ADDRESSER ЛОГИЧЕСКИЕ АДРЕСА СИСТЕМЫ DALI DALI智能调光系统计算机指定控制参数
1 (2 mA)	1

Art. MY83 - BZM4

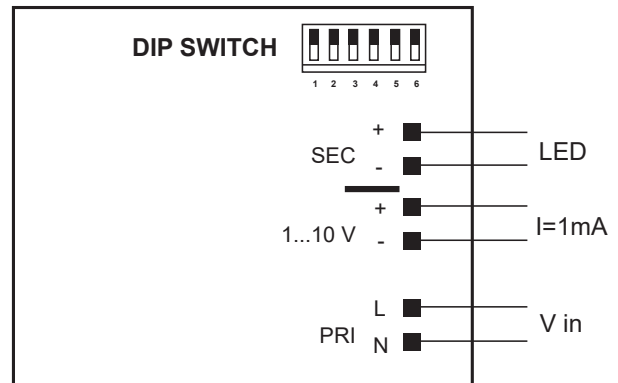

Art. KC55

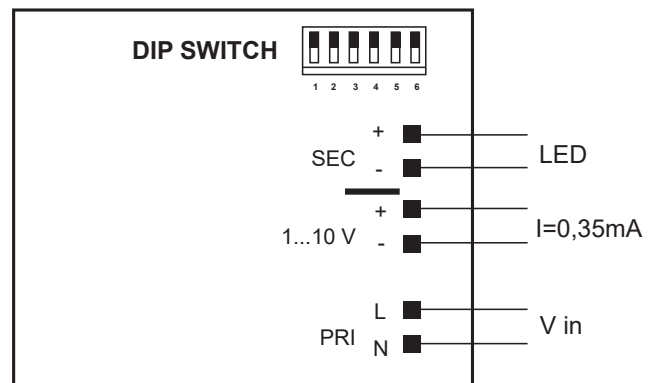

DRIVER SETTING

1

**CURRENT
XXX mA**

2

**DIP SWITCH
CURRENT
SETTING**

Art. QC34 - QC35 - QC36 - QC37 - QC38 - QC39 - QX23 - QX24 - QX25

Art. QC40 - QC41 - QC42 - QC43 - QC44 - QC45 - QC46 - QC47
QX26 - QX27 - QX28 - QX29

DIP SWITCH position
Art. X020

DIP SWITCH position	1	2	3	4
250mA	-	-	-	-
350mA	-	-	-	ON
400mA	-	-	ON	-
450mA	-	ON	-	-
500mA	-	-	ON	ON
550mA	-	ON	-	ON
650mA	-	ON	ON	-
700mA	-	ON	ON	ON
24V	ON	ON	ON	ON

DIP SWITCH position
Art. KC55

DIP SWITCH position	1	2	3	4	5	6
250mA	-	-	-	-	-	-
300mA	-	-	-	-	-	ON
350mA	-	-	-	-	ON	-
400mA	-	-	-	-	ON	ON
450mA	-	-	-	ON	-	-
500mA	-	-	-	ON	-	ON
550mA	-	-	-	ON	ON	-
600mA	-	-	-	ON	ON	ON
650mA	-	-	ON	-	ON	-
700mA	-	-	ON	-	ON	ON
750mA	-	-	ON	ON	-	-
800mA	-	-	ON	ON	-	ON
850mA	-	-	ON	ON	ON	-
900mA	-	-	ON	ON	ON	ON
12V	-	ON	ON	ON	ON	ON
24V	ON	-	ON	ON	ON	ON

Art. QC34 - QC35 - QC36 - QC37 - QC38 - QC39 - QX23 - QX24 - QX25

DIP SWITCH position
Art. MY83 - BZM4 - MZ84

DIP SWITCH position	1	2	3	4	5	6
350mA	-	-	-	-	-	-
500mA	-	-	-	-	-	ON
550mA	-	-	-	-	ON	-
650mA	-	-	ON	-	-	ON
700mA	-	-	-	-	ON	ON
750mA	-	-	-	ON	ON	-
850mA	-	ON	-	-	-	ON
900mA	-	-	-	ON	ON	ON
1000mA	-	ON	ON	-	-	ON
1050mA	-	-	ON	ON	ON	ON

Art. QC40 - QC41 - QC42 - QC43 - QC44 - QC45 - QC46 - QC47
QX26 - QX27 - QX28 - QX29

Art. QC40 - QC41 - QC42 - QC43 - QC44 - QC45 - QC46 - QC47
QX26 - QX27 - QX28 - QX29

DIP SWITCH position
Art. MY83 - BZM4 - MZ84

DIP SWITCH position	1	2	3	4	5	6
350mA	-	-	-	-	-	-
500mA	-	-	-	-	-	ON
550mA	-	-	-	-	ON	-
650mA	-	-	ON	-	-	ON
700mA	-	-	-	-	ON	ON
750mA	-	-	-	ON	ON	-
850mA	-	ON	-	-	-	ON
900mA	-	-	-	ON	ON	ON
1000mA	-	ON	ON	-	-	ON
1050mA	-	-	ON	ON	ON	ON

DIP SWITCH position
Art. PA19

DIP SWITCH position	1	2	3	4
250mA	-	-	-	-
300mA	-	-	-	ON
350mA	-	-	ON	-
400mA	-	-	ON	ON
450mA	-	ON	-	-
500mA	-	ON	-	ON
550mA	-	ON	ON	-
600mA	-	ON	ON	ON
650mA	ON	-	-	-
700mA	ON	-	-	ON

DIP SWITCH position
 Art. PD41

DIP SWITCH position	1	2	3	4
125mA	-	-	-	-
150mA	-	-	-	ON
175mA	-	-	ON	-
200mA	-	-	ON	ON
225mA	-	ON	-	-
250mA	-	ON	-	ON
275mA	-	ON	ON	-
300mA	-	ON	ON	ON
325mA	ON	-	-	-
350mA	ON	-	-	ON
375mA	ON	-	ON	-
400mA	ON	-	ON	ON
425mA	ON	ON	-	-
450mA	ON	ON	-	ON
475mA	ON	ON	ON	-
500mA	ON	ON	ON	ON

DIP SWITCH position
 Art. KC55

DIP SWITCH position	1	2	3	4	5	6
250mA	-	-	-	-	-	-
300mA	-	-	-	-	-	ON
350mA	-	-	-	-	ON	-
400mA	-	-	-	-	ON	ON
450mA	-	-	-	ON	-	-
500mA	-	-	-	ON	ON	ON
550mA	-	-	-	ON	ON	-
600mA	-	-	-	ON	ON	ON
650mA	-	-	ON	-	ON	-
700mA	-	-	ON	-	ON	ON
750mA	-	-	ON	ON	-	-
800mA	-	-	ON	ON	-	ON
850mA	-	-	ON	ON	ON	-
900mA	-	-	ON	ON	ON	ON
12V	-	ON	ON	ON	ON	ON
24V	ON	-	ON	ON	ON	ON

DIP SWITCH position
 Art. PA19

DIP SWITCH position	1	2	3	4
250mA	-	-	-	-
300mA	-	-	-	ON
350mA	-	-	ON	-
400mA	-	-	ON	ON
450mA	-	ON	-	-
500mA	-	ON	-	ON
550mA	-	ON	ON	-
600mA	-	ON	ON	ON
650mA	ON	-	-	-
700mA	ON	-	-	ON

ART	N° LED		
	D=19 mm	D=37 mm	D=51 mm
X020	MAX 9	/	/
MZ84	MAX 22	MAX 5	/
PD41	/	/	MAX 1
MY83	MAX 22	MAX 5	/
KC55	/	MAX 3	MAX 1
BZM4	MAX 22	MAX 5	/
PA19	/	MAX 3	MAX 1

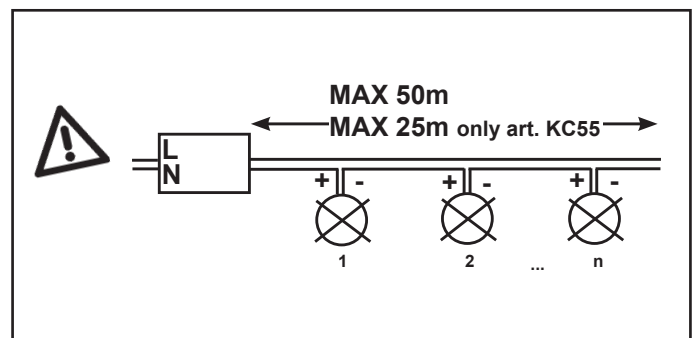

IT In caso di danneggiamento del cavo flessibile esterno, questo deve essere sostituito dal costruttore, o dal suo servizio di assistenza, o da personale qualificato equivalente, al fine di evitare pericoli.

EN Should the outer flexible cable be somehow damage, the latter should be replaced by the manufacturer, or by the corresponding service centre, or by an appropriate and qualified member of staff in order to avoid all risk of danger.

FR Si le câble flexible extérieur est abîmé, faites-le remplacer par le fabricant, par son service après-vente ou par un professionnel du secteur agréé afin d'éviter tout danger.

DE Sollte das äußere Kabel beschädigt sein, so muss es aus Sicherheitsgründen vom Hersteller, dessen Kundendienst oder von dazu autorisiertem Personal ausgewechselt werden.

NL Mocht de externe flexibele slang beschadigd worden, dan moet deze worden vervangen door de fabrikant of door een bevoegde installateur, zodat eventueel gevaar vermeden wordt.

ES En caso de daños el cable flexible externo debe substituirse por el fabricante, su servicio de asistencia o personal calificado equivalente para evitar peligros.

DA Hvis den yderste ledning beskadiges, skal den udskiftes af producenten eller et autoriseret teknisk servicecenter, eller af kvalificerede fagfolk, så man undgår farlige situationer.

NO Hvis ytre fleksible kabel skulle bli skadet, skal denne skiftes ut av produsenten eller tilsvarende servicesenter eller av en egnet og kvalifisert fagperson for å unngå farens risiko.

SV Om den yttre kabeln skadas ska den bytas ut av tillverkaren, av dess auktoriserade verkstad eller av likvärdig kvalificerad personal för att undvika alla typer av risker.

RU В случае повреждения внешнего гибкого кабеля во избежание риска поручите его замену производителю, уполномоченному сервису или квалифицированному электрику.

ZH 如果外部软缆损坏，须由生产商、对应服务中心或能胜任和资深的员工更换新的电缆，以避免任何可能的危险。

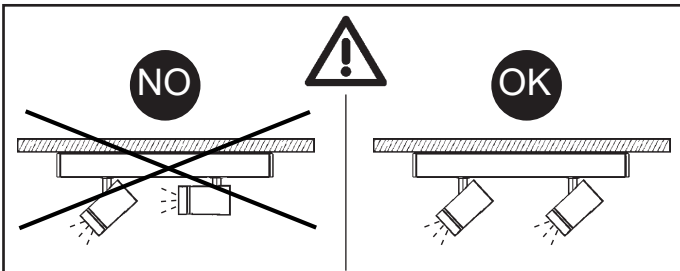

+ Art.

Ø	19 mm		37 mm		51 mm			
	MZ49	MZ52	MZ48	MZ51	MZ43	MZ45	MZ47	MZ50
19 mm	×	×	×	×	×	×	×	×
37 mm	✓	×	✓	×	✓	×	✓	×
51 mm	×	✓	×	✓	×	✓	×	✓

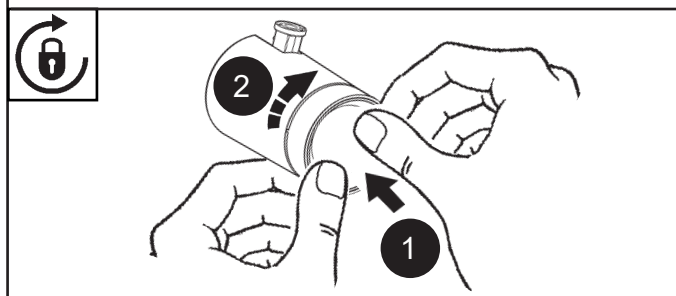
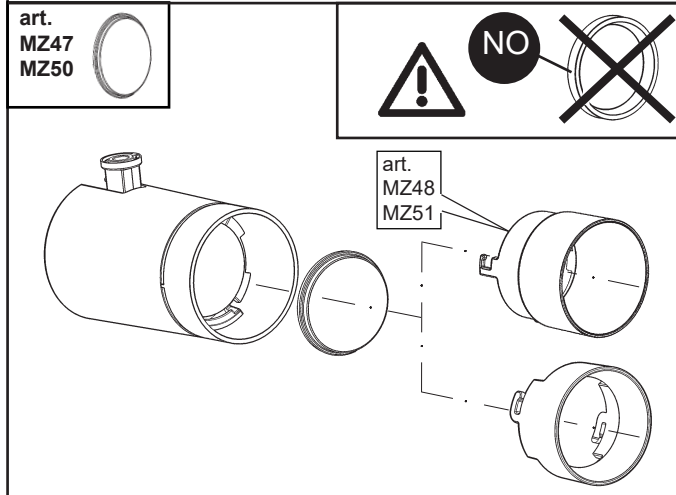
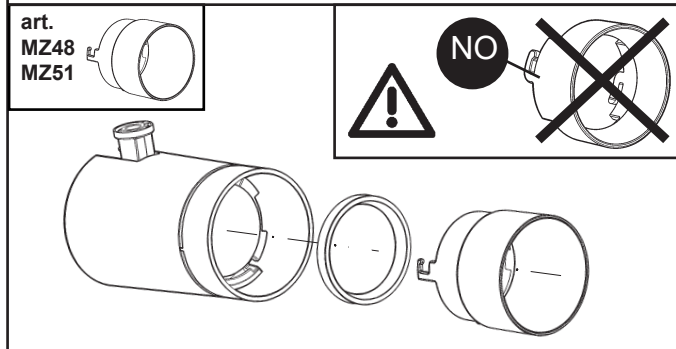
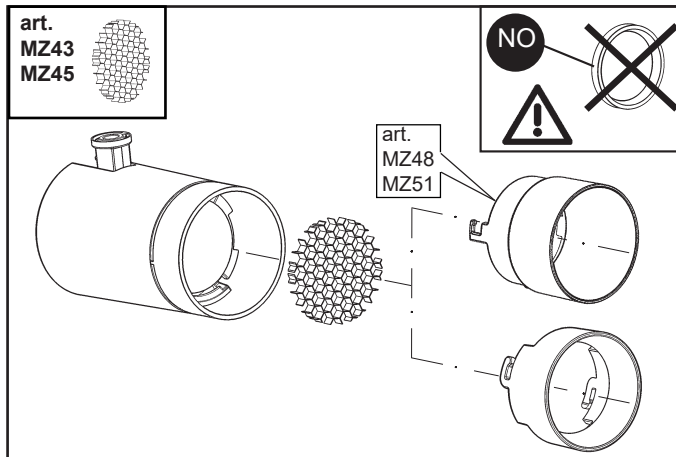
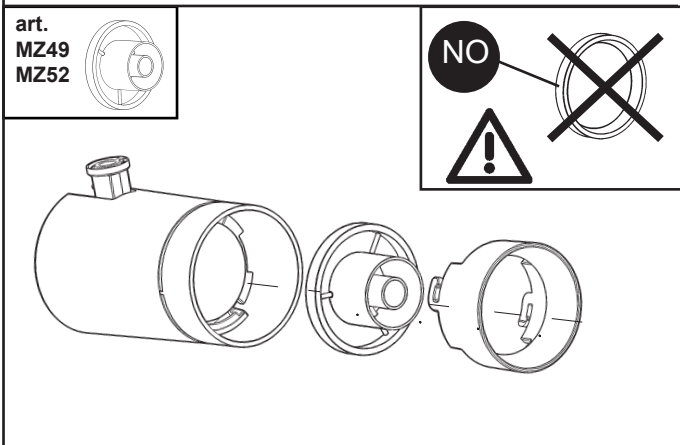
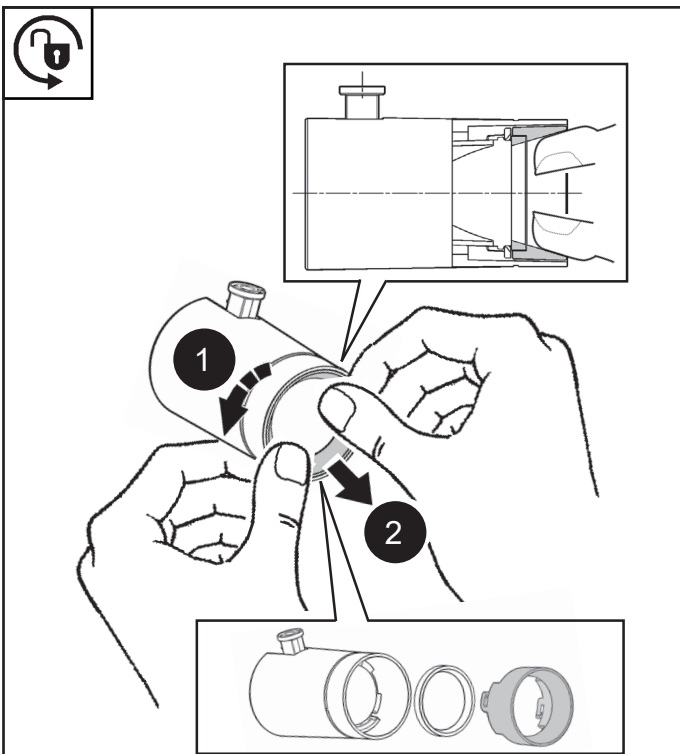

IT N.B.: Per la sostituzione del LED contattare l'azienda iGuzzini.

EN N.B.: For information on LED replacement please contact iGuzzini.

FR N.B.: Pour procéder au remplacement de la LED, adressez-vous à la société iGuzzini.

DE N.B.: Bezüglich des Austausches der LED kontaktieren Sie bitte die Firma iGuzzini.

NL N.B.: Voor het vervangen van de LED neemt u contact op met het bedrijf iGuzzini.

ES NOTA: Para sustituir el LED llame a la empresa iGuzzini.

DA N.B.: For udskiftning af lysdioden, skal man kontakte iGuzzini.

NO N.B.: For informasjon om skifte av LED, vennligst ta kontakt med iGuzzini.

SV OBS! För byte av lysdioden, kontakta företaget iGuzzini.

RU ПРИМЕЧАНИЕ: Для замены СИДов обращайтесь в компанию iGuzzini.

ZH 注意：如需LED更换的信息，请联系iGuzzini。

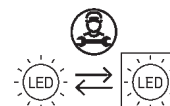

PALCO SURFACE (remote driver)

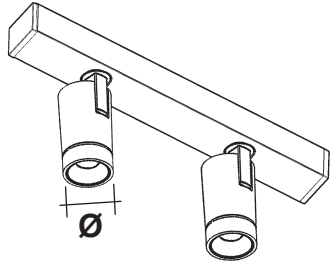

Ø	PRODUCT	الصنف ART
19 mm		QC34 - QC35 - QX23
2x19 mm		QC36 - QC37 - QX24
3x19 mm		QC38 - QC39 - QX25
37 mm		QC40 - QC41 - QC42 QC43 - QX26 - QX27
2x37 mm		QC44 - QC45 - QX28
3x37mm		QC46 - QC47 - QX29
51 mm		QC48 - QC49 - QC50 QC51 - QX30 - QX31
2x51 mm		QC52 - QC53 - QX32
3x51mm		QC54 - QC55 - QX33

تحذير :

AR لا يمكن ضمان سلامة هذا الجهاز إلا إذا التزمت بهذه التعليمات، يجب حفظها في مكان آمن.

IT ATTENZIONE:

LA SICUREZZA DELL'APPARECCHIO E' GARANTITA SOLO CON L'USO APPROPRIATO DELLE SEGUENTI ISTRUZIONI; PERTANTO E' NECESSARIO CONSERVARLE.

EN WARNING:

THE SAFETY OF THIS FIXTURE IS GUARANTEED ONLY IF YOU COMPLY WITH THESE INSTRUCTIONS; REMEMBER TO CONSERVE IN A SAFE PLACE.

ES ATENCION:

LA SEGURIDAD DEL APARATO SE GARANTIZA SOLO CUMPLIENDO CUIDADOSAMENTE LAS SIGUIENTES INSTRUCCIONES; POR ELLO, ES NECESARIO CONSERVARLAS.

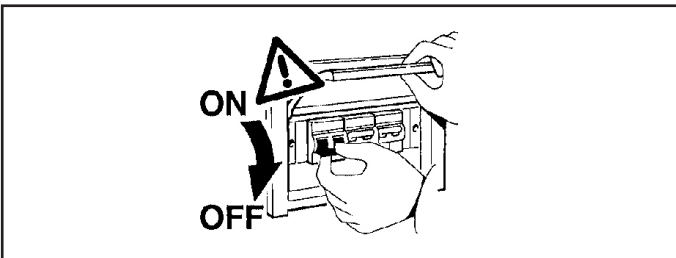

AR ملاحظة: ملاحظة: أثناء تركيب نظام. يجب التقيد بحرص بالنظم السائدة المتعلقة بالشبكة الكهربائية.

IT N.B.: DURANTE L'INSTALLAZIONE DEL SISTEMA RISPETTARE SCRUPOLOSAMENTE LE NORME IMPIANTISTICHE VIGENTI.

EN N.B.: WHEN INSTALLING THE SYSTEM STRICTLY COMPLY WITH ALL REGULATIONS ON INSTALLATION IN FORCE.

ES N.B.: DURANTE LA INSTALACIÓN DEL SISTEMA RESPETAR ESCRUPULOSAMENTE LAS NORMAS DE INSTALACIÓN VIGENTES.

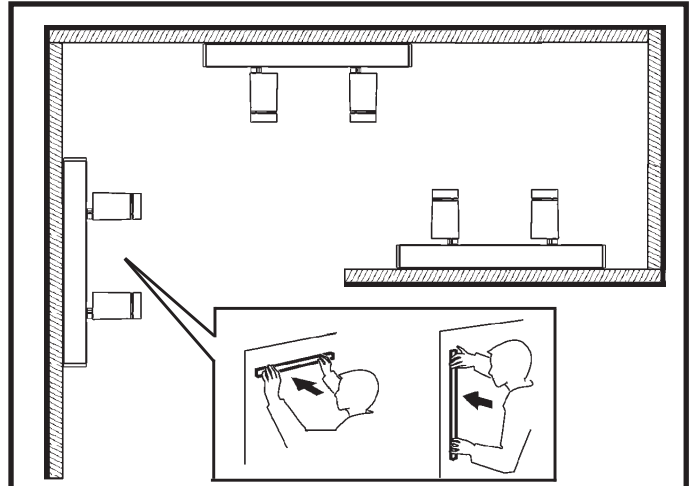

AR في ما يتعلق بأوضاع التركيب، التزم بما هو موضح ومحدد، إذا دعت الضرورة اتصل بـ iGuzzini

IT Per le posizioni di installazione, attenersi a quelle illustrate, eventualmente contattare la iGuzzini.

EN All installation positions must comply with those illustrated. In the event of any doubt, contact iGuzzini.

ES Respetar las posiciones de instalación ilustradas y, en caso de duda, contactar con iGuzzini

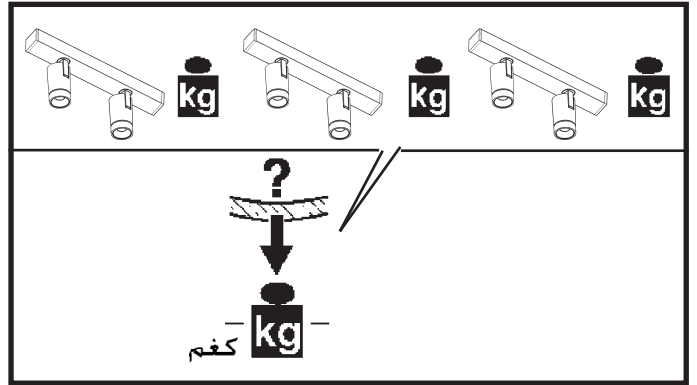

AR

يجب أن تُركب فقط خارج مكان الدخول.

IT DA INSTALLARE SOLO AL DI FUORI DEL VOLUME DI ACCESSIBILITA'

EN TO BE INSTALLED ONLY OUTSIDE THE ACCESSIBLE SPACE

ES ALLEEN TE INSTALLEREN BUITEN HET TOEGANKELIJKHEIDSGEBIED

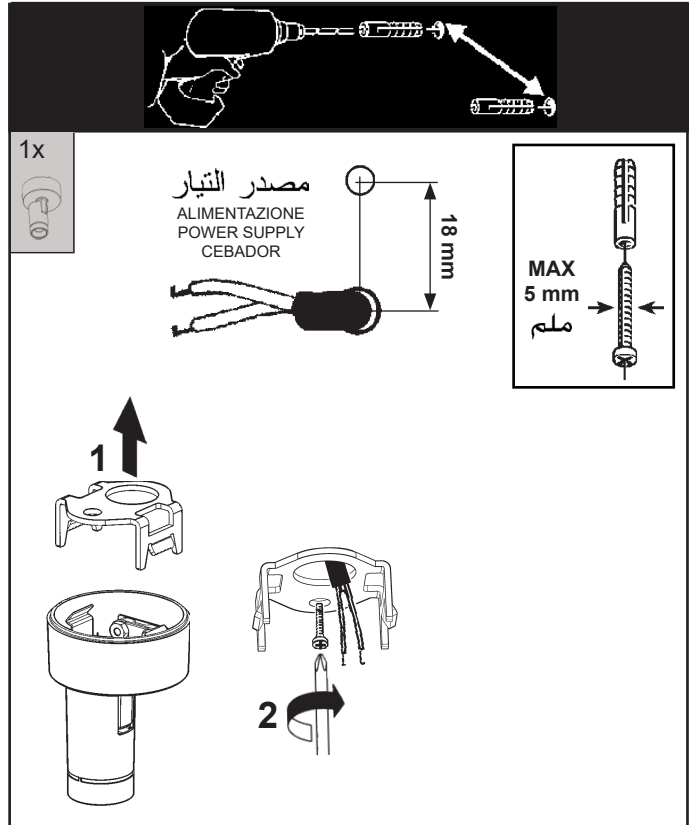

1x

مصدر التيار

ALIMENTAZIONE
POWER SUPPLY
CEBADOR

18 mm

MAX
5 mm
ملم

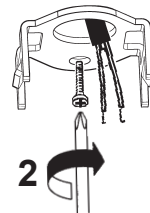
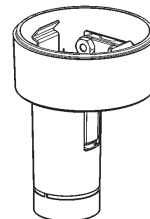

2

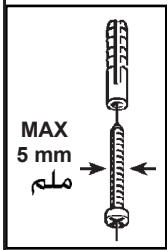
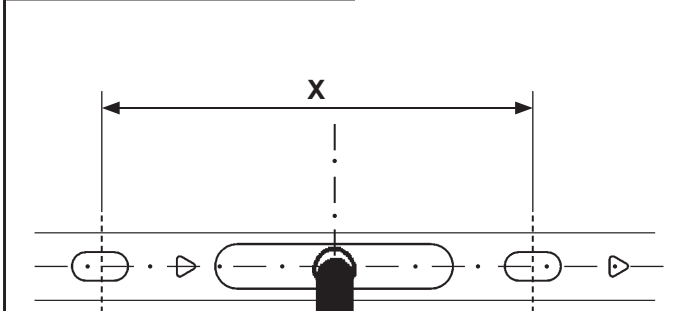
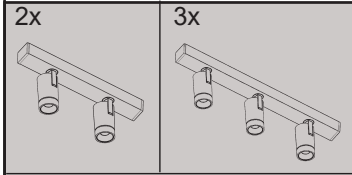
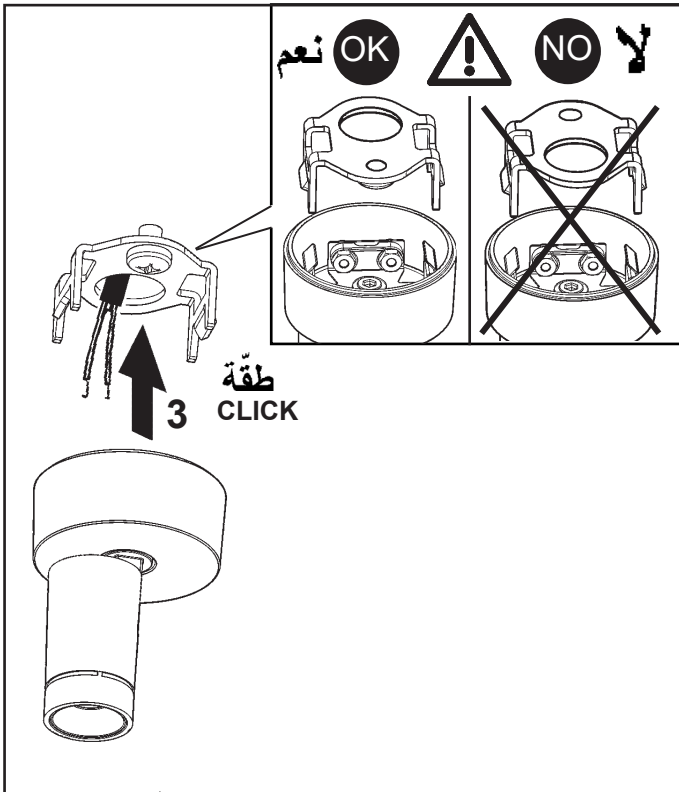

مصدر التيار
ALIMENTAZIONE
POWER SUPPLY
CEBADOR



الصف ART.	QC36 - QC37 QX24	QC38 - QC39 QX25	QC44 - QC45 QC52 - QC53 QX28 - QX32	QC46 - QC47 QC54 - QC55 QX29 - QX33
X (mm)	78	140	210	350

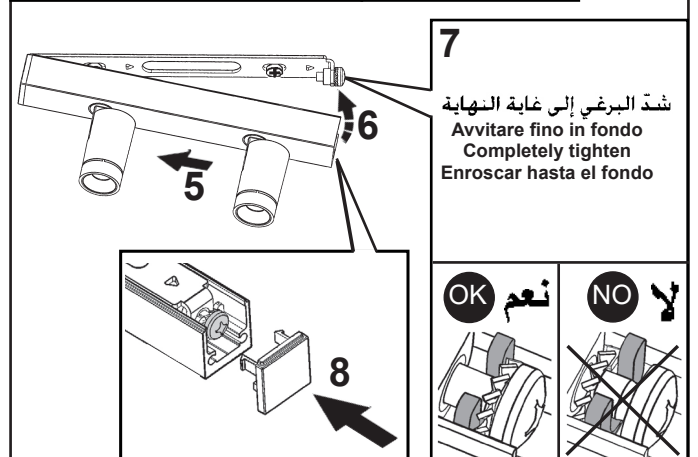
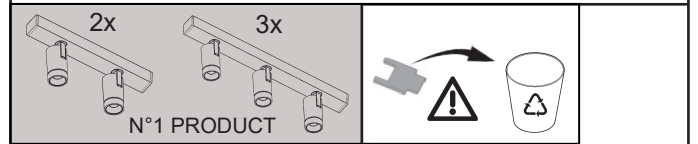
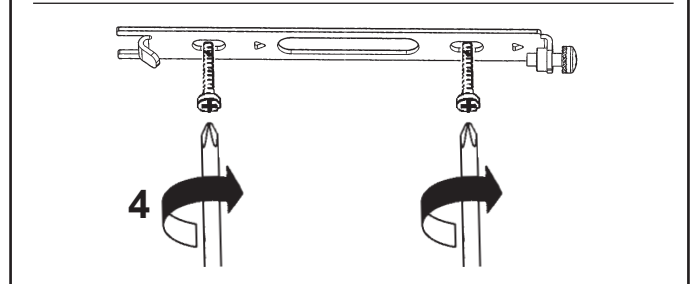
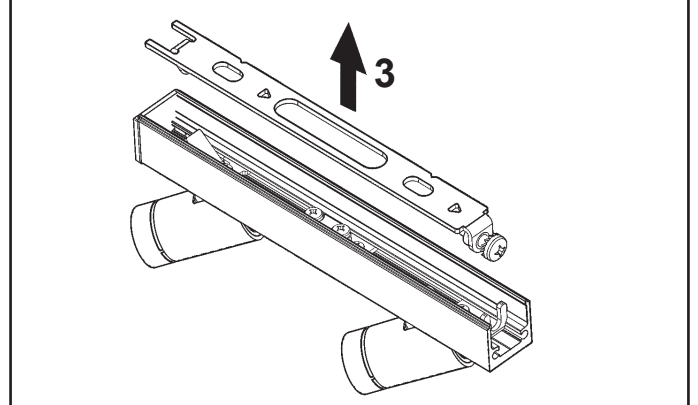
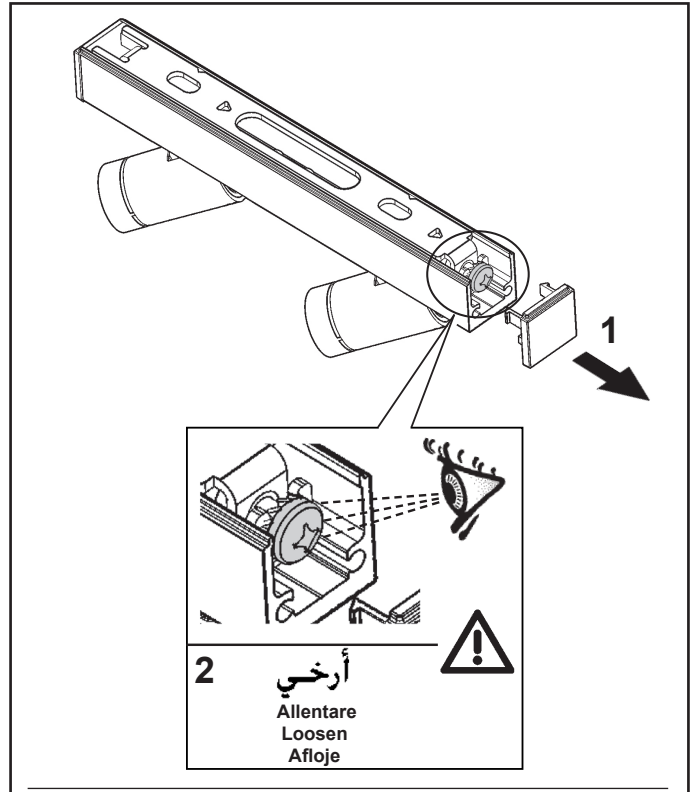

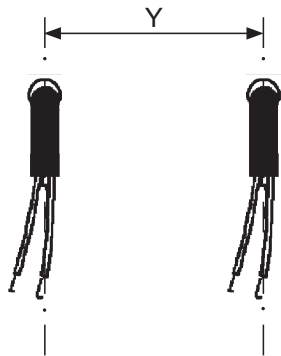
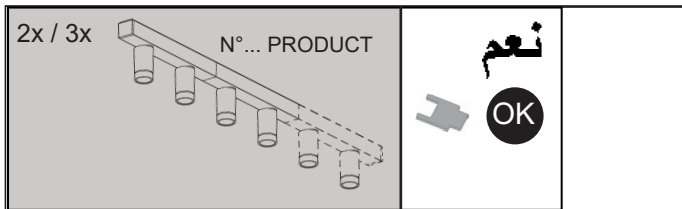

	Ø (mm)	(2x + 2x)	(3x + 3x)	(2x + 3x)
Y (mm)	19	144	216	180
	37 51	284	426	355

5
شدّ البرغي إلى غاية النهاية
Avvitare fino in fondo
Completely tighten
Enroscar hasta el fondo

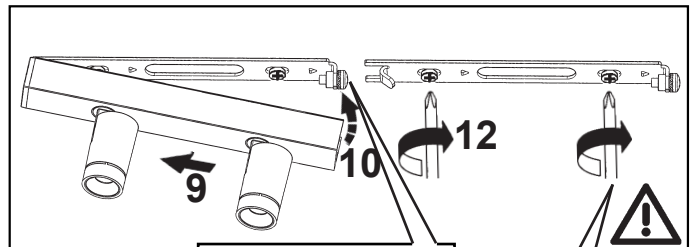
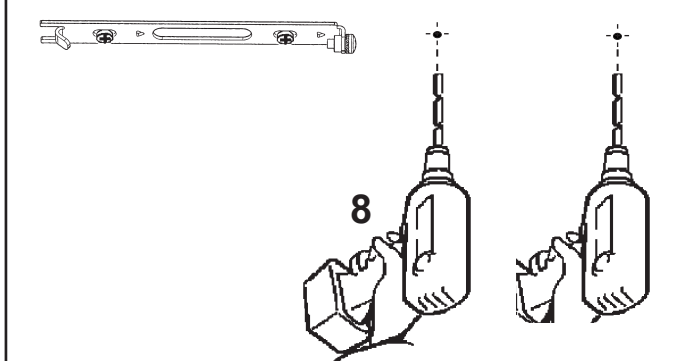
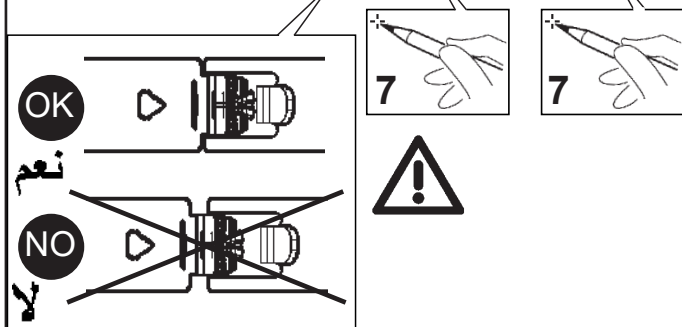
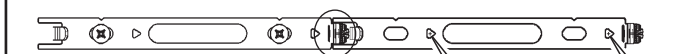
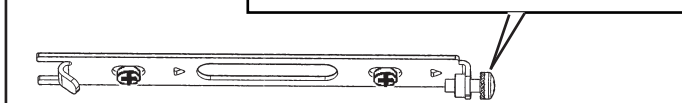

11
شدّ البرغي إلى غاية النهاية
Avvitare fino in fondo
Completely tighten
Enroscar hasta el fondo

نعم OK

لا NO

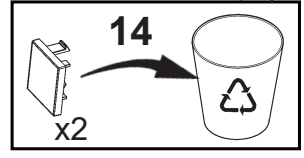
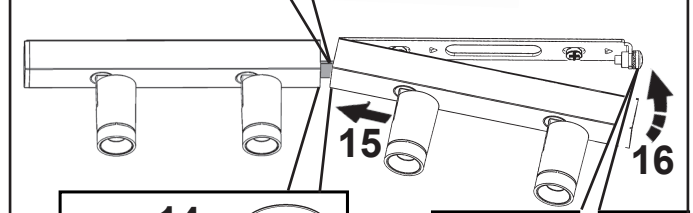
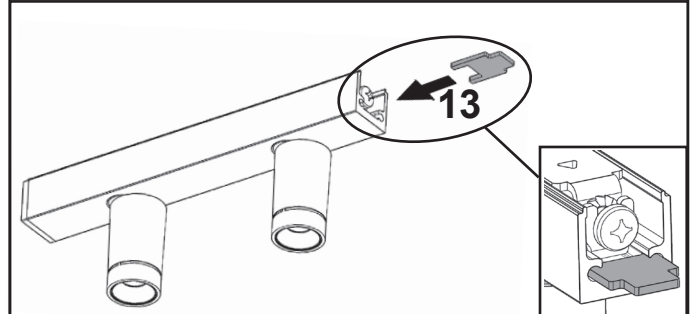

17
شدّ البرغي إلى غاية النهاية
Avvitare fino in fondo
Completely tighten
Enroscar hasta el fondo

نعم OK

لا NO

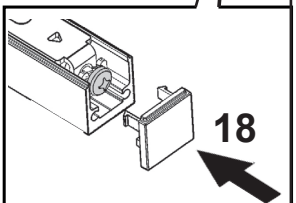
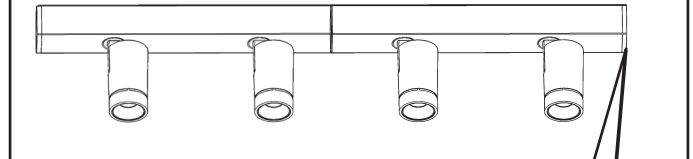

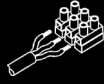

يتم ضمان عمل الجهاز بشكل جيد من خلال تأرجح فلتية التغذية الخارجة بنسبة $\pm 5\%$ مقارنة مع القيمة الاسمية.
المطابقة للمعيار مضمونة فقط عند استخدام محولات جودزيني "iGuzzini"
(وفقاً للمادة: PD41 - KC55 - PA19 - BZM4 - MZ84 - X020 - MY83)

- IT Le prestazioni e la sicurezza dell'apparecchio sono garantite soltanto per oscillazioni della corrente del $\pm 5\%$ rispetto al valore nominale.
La conformità alla norma è garantita soltanto utilizzando gruppi driver iGuzzini (art.: PD41 - KC55 - PA19 - BZM4 - MZ84 - X020 - MY83).
Nel caso di utilizzo di driver diversi, per tutte le informazioni tecniche aggiuntive, contattare la iGuzzini
- EN The performance level and safety of the lighting fixture are only guaranteed for oscillations of $\pm 5\%$ in the current, in relation to the nominal value.
Conformity with the standard is guaranteed only if iGuzzini driver assemblies (item code PD41 - KC55 - PA19 - BZM4 - MZ84 - X020 - MY83) are used.
When using other drivers, contact iGuzzini for any additional technical information
- ES Las prestaciones y la seguridad del aparato están garantizadas solamente con oscilaciones de la corriente del $\pm 5\%$ respecto al valor nominal.
La conformidad a la norma se garantiza solamente con el uso de alimentadores iGuzzini (art. PD41 - KC55 - PA19 - BZM4 - MZ84 - X020 - MY83) o equivalentes de tipo SELV que cumplen las normas vigentes C.E.I

- AR يجب أن تكون وحدة التغذية الخارجية SELV
- IT L'unità di alimentazione esterna deve essere SELV.
- EN The external power supply unit must be SELV
- ES La unidad de alimentación exterior ha de ser SELV

- AR أوصل المحول بالشبكة الكهربائية، باتباع التعليمات فقط بعد توصيل المنتجات.
- IT Cablare alla rete elettrica il trasformatore solo dopo aver effettuato il collegamento ai prodotti
- EN Wire the transformer to the electrical mains only after the connection to the products has been carried out
- ES Cablear el transformador a la red eléctrica sólo después de conectar los productos

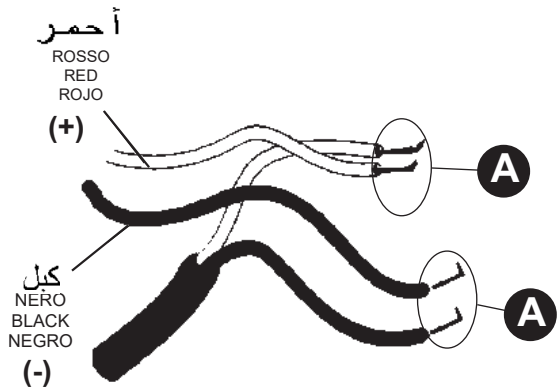
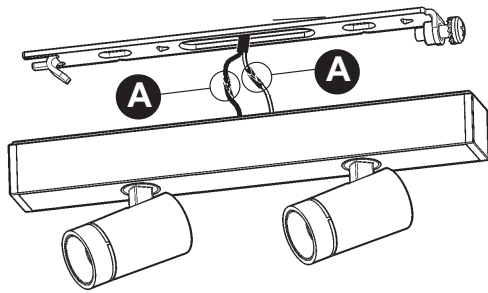
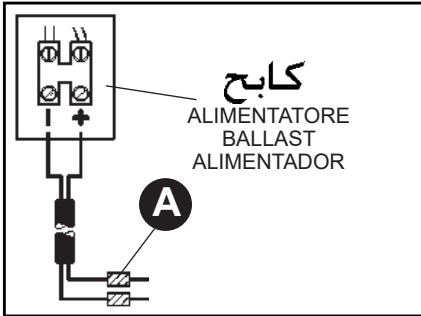

شريط يتكثّل بشكل ذاتي

NASTRO AUTOAGGLOMERANTE
SELF-VULCANISING TAPE
CINTA AUTOAGLOMERANTE
(SCOTCH 23 3M)

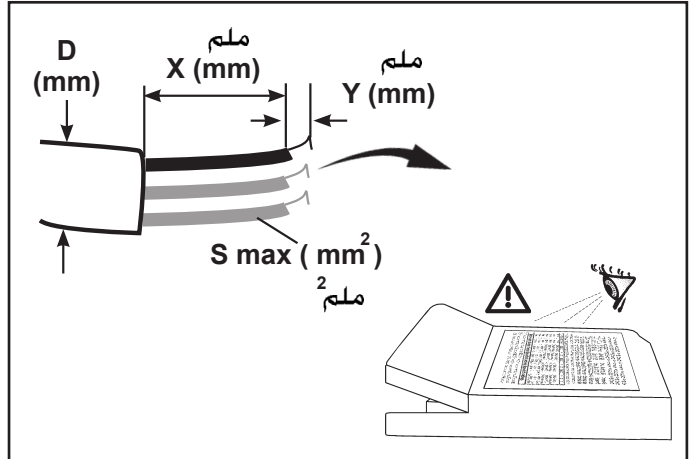

	S mm ²	Y mm	X mm	D mm
TCI - UNIVERSALE	0,5 - 1,5	8,5 - 9,5	30	3 - 8
PRO FLAT	0,75 - 1,5	8,5 - 9,5	30	3 - 10
DC JOLLY DALI - DC JOLLY US	0,75 - 1,5	8,5 - 9,5	30	3 - 8
TCI - DC MAXI JOLLY US	0,5 - 2,5	/	30	3 - 8
TCI - DC MAXI JOLLY US DALI				
TCI - MP 50 K3				

DALI VERSION
Art. PA19 - BZM4
الصف

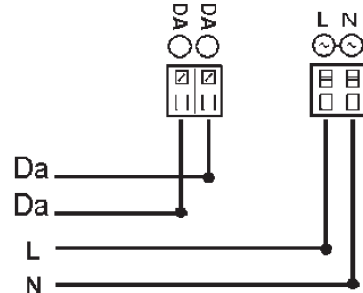

PUSH DIM
Art. KC55 - MY83 - BZM4

الصنف

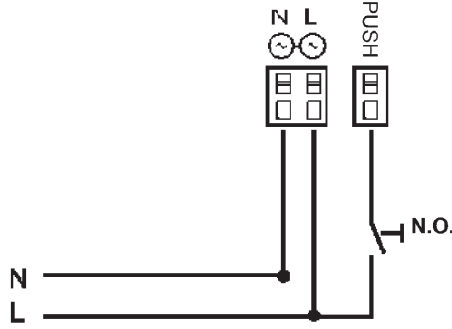

Art. KC55 - MY83 -BZM4

AR يمكن أن يتم تخفيض إضاءة الأجهزة ذات الكابلات الرقمية؛ وذلك عن طريق استخدام أجهزة الإمداد بالطاقة الكهربائية "دالي" (DALI)، أو عن طريق استخدام زر يكون مفتوحًا في وضعه الطبيعي (N.O.)؛ حيث يتم التوصيل كما هو مبين في المخطط.

IT I dispositivi con cablaggio digitale possono essere dimmerati con dispositivi DALI o con pulsante normalmente aperto (N.O.) da collegare come da schema.

EN Devices with digital control gear may be dimmed using DALI devices or a normally-open button (N.O.) to be connected as shown in the diagram.

ES Los dispositivos con cableado digital pueden regularse con dispositivos DALI o con un interruptor de botón normalmente abierto (N.O.) que se conecta según ilustrado en el esquema.

AR يمكن أن يتسبب التحكم في منتجات "دالي" المختلفة عن طريق الأزرار (مثل الأزرار: "تنش - ديم"، "سويتش - ديم"، "بوتن - ديم"، "دايركت - ديم"، إلخ)، في حدوث مشاكل تتعلق بعملية التزامن بين هذه الأزرار. وإن كان من الممكن تجنب مثل هذه المشاكل، وذلك عن طريق تزويد بعض الأجهزة الإضافية بدعمك للاتصال المباشر بالشبكة؛ وذلك للحصول على أكبر قدر من المطبوعات.

IT Pilotare diversi prodotti DALI tramite pulsante (es: Touch-dim, Switch-dim, Push-dim, Direct-dim, etc.) potrebbe causare dei problemi di sincronizzazione tra gli stessi. È possibile ovviare a questo problema dotandosi di dispositivi aggiuntivi. Per maggiori informazioni vi invitiamo a contattarci direttamente.

EN Controlling different DALI products through buttons (e.g.: Touch-dim, Switch-dim, Push-dim, Direct-dim, etc.) may lead to product synchronisation problems. This problem can be overcome by using additional devices. For further information, please contact us directly.

ES El mando de varios productos DALI por tecla (ej: Touch-dim, Switch-dim, Push-dim, Direct-dim, etc.) podría causar problemas de sincronización entre ellos. Es posible prevenir este problema utilizando dispositivos adicionales. Para más información, contacte directamente con nosotros.

AR يتم ضمان العزل بين موصلات التغذية بالطاقة وموصلات التحكم الأساسي

IT Tra i conduttori di alimentazione e quelli di controllo è garantito un isolamento doppio.

EN Insulation is guaranteed between the power supply wires and the control wires double.

ES Entre los conductores de alimentación y los de control está garantizado el aislamiento doble.

شحنة DALI / حمل DALI CARICO DALI / DALI LOAD CHARGE DALI CARGA DALI	عناوين DALI INDIRIZZI DALI DALI ADDRESSES DIRECCIONES DALI
1 (2 mA)	1

Art. MY83 - BZM4
الصنف

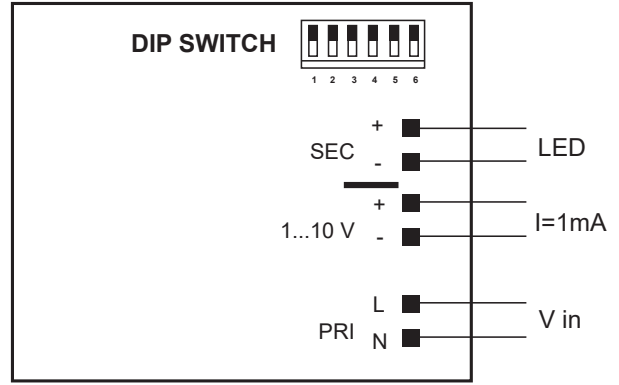

Art. KC55
الصنف

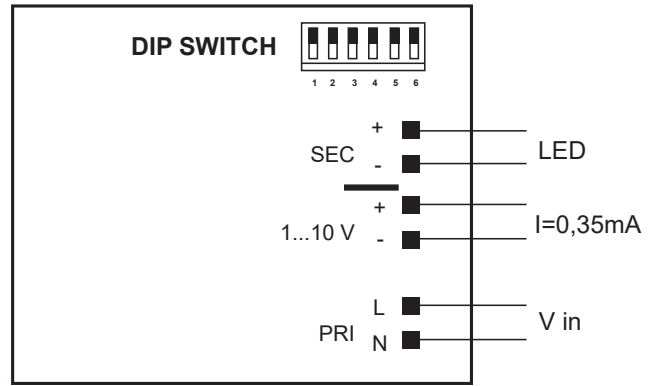

DRIVER SETTING

1

**! CURRENT
XXX mA**

2

**! DIP SWITCH
CURRENT
SETTING**

Art. QC34 - QC35 - QC36 - QC37 - QC38 - QC39 - QX23 - QX24 - QX25

DIP SWITCH position

Art. X020



DIP SWITCH position	1	2	3	4
250mA	-	-	-	-
350mA	-	-	-	ON
400mA	-	-	ON	-
450mA	-	ON	-	-
500mA	-	-	ON	ON
550mA	-	ON	-	ON
650mA	-	ON	ON	-
700mA	-	ON	ON	ON
24V	ON	ON	ON	ON

Art. QC34 - QC35 - QC36 - QC37 - QC38 - QC39 - QX23 - QX24 - QX25

DIP SWITCH position

Art. MY83 - BZM4 - MZ84

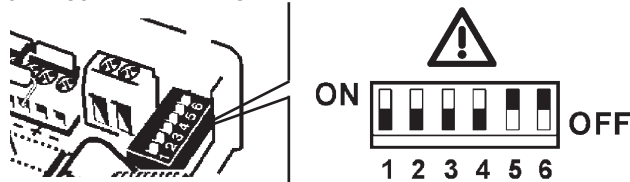

DIP SWITCH position	1	2	3	4	5	6
350mA	-	-	-	-	-	-
500mA	-	-	-	-	-	ON
550mA	-	-	-	-	ON	-
650mA	-	-	ON	-	-	ON
700mA	-	-	-	-	ON	ON
750mA	-	-	-	ON	ON	-
850mA	-	ON	-	-	-	ON
900mA	-	-	-	ON	ON	ON
1000mA	-	ON	ON	-	-	ON
1050mA	-	-	ON	ON	ON	ON

Art. QC40 - QC41 - QC42 - QC43 - QC44 - QC45 - QC46 - QC47
QX26 - QX27 - QX28 - QX29

DIP SWITCH position

Art. MY83 - BZM4 - MZ84

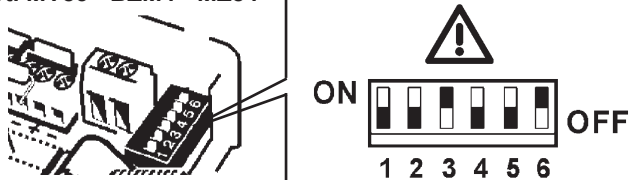

DIP SWITCH position	1	2	3	4	5	6
350mA	-	-	-	-	-	-
500mA	-	-	-	-	-	ON
550mA	-	-	-	-	ON	-
650mA	-	-	ON	-	-	ON
700mA	-	-	-	-	ON	ON
750mA	-	-	-	ON	ON	-
850mA	-	ON	-	-	-	ON
900mA	-	-	-	ON	ON	ON
1000mA	-	ON	ON	-	-	ON
1050mA	-	-	ON	ON	ON	ON

Art. QC40 - QC41 - QC42 - QC43 - QC44 - QC45 - QC46 - QC47
QX26 - QX27 - QX28 - QX29

DIP SWITCH position

Art. KC55

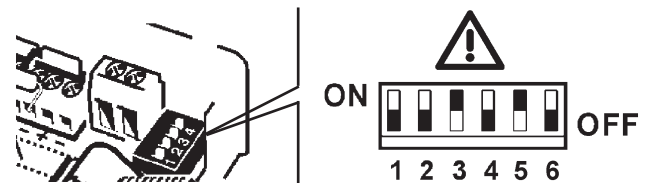

DIP SWITCH position	1	2	3	4	5	6
250mA	-	-	-	-	-	-
300mA	-	-	-	-	-	ON
350mA	-	-	-	-	ON	-
400mA	-	-	-	-	ON	ON
450mA	-	-	-	ON	-	-
500mA	-	-	-	ON	-	ON
550mA	-	-	-	ON	ON	-
600mA	-	-	-	ON	ON	ON
650mA	-	-	ON	-	ON	-
700mA	-	-	ON	-	ON	ON
750mA	-	-	ON	ON	-	-
800mA	-	-	ON	ON	-	ON
850mA	-	-	ON	ON	ON	-
900mA	-	-	ON	ON	ON	ON
12V	-	ON	ON	ON	ON	ON
24V	ON	-	ON	ON	ON	ON

Art. QC40 - QC41 - QC42 - QC43 - QC44 - QC45 - QC46 - QC47
QX26 - QX27 - QX28 - QX29

DIP SWITCH position

Art. PA19



DIP SWITCH position	1	2	3	4
250mA	-	-	-	-
300mA	-	-	-	ON
350mA	-	-	ON	-
400mA	-	-	ON	ON
450mA	-	ON	-	-
500mA	-	ON	-	ON
550mA	-	ON	ON	-
600mA	-	ON	ON	ON
650mA	ON	-	-	-
700mA	ON	-	-	ON

DIP SWITCH position
Art. PD41

DIP SWITCH position	1	2	3	4
125mA	-	-	-	-
150mA	-	-	-	ON
175mA	-	-	ON	-
200mA	-	-	ON	ON
225mA	-	ON	-	-
250mA	-	ON	-	ON
275mA	-	ON	ON	-
300mA	-	ON	ON	ON
325mA	ON	-	-	-
350mA	ON	-	-	ON
375mA	ON	-	ON	-
400mA	ON	-	ON	ON
425mA	ON	ON	-	-
450mA	ON	ON	-	ON
475mA	ON	ON	ON	-
500mA	ON	ON	ON	ON

DIP SWITCH position
Art. KC55

DIP SWITCH position	1	2	3	4	5	6
250mA	-	-	-	-	-	-
300mA	-	-	-	-	-	ON
350mA	-	-	-	-	ON	-
400mA	-	-	-	-	ON	ON
450mA	-	-	-	ON	-	-
500mA	-	-	-	ON	-	ON
550mA	-	-	-	ON	ON	-
600mA	-	-	-	ON	ON	ON
650mA	-	-	ON	-	ON	-
700mA	-	-	ON	-	ON	ON
750mA	-	-	ON	ON	-	-
800mA	-	-	ON	ON	-	ON
850mA	-	-	ON	ON	ON	-
900mA	-	-	ON	ON	ON	ON
12V	-	ON	ON	ON	ON	ON
24V	ON	-	ON	ON	ON	ON

DIP SWITCH position
Art. PA19

DIP SWITCH position	1	2	3	4
250mA	-	-	-	-
300mA	-	-	-	ON
350mA	-	-	ON	-
400mA	-	-	ON	ON
450mA	-	ON	-	-
500mA	-	ON	-	ON
550mA	-	ON	ON	-
600mA	-	ON	ON	ON
650mA	ON	-	-	-
700mA	ON	-	-	ON

N° LED	الصنف ART		
	QC34 - QC35 QC36 - QC37 QC38 - QC39 QX23 - QX24 QX25	QC40 - QC41 QC42 - QC43 QC44 - QC45 QC46 - QC47 QX26 - QX27 QX28 - QX29	QC48 - QC49 QC50 - QC51 QC52 - QC53 QC54 - QC55 QX30 - QX31 QX32 - QX33
X020	MAX 9	/	/
MZ84	MAX 22	MAX 5	/
PD41	/	/	MAX 1
MY83	MAX 22	MAX 5	/
KC55	/	MAX 3	MAX 1
BZM4	MAX 22	MAX 5	/
PA19	/	MAX 3	MAX 1

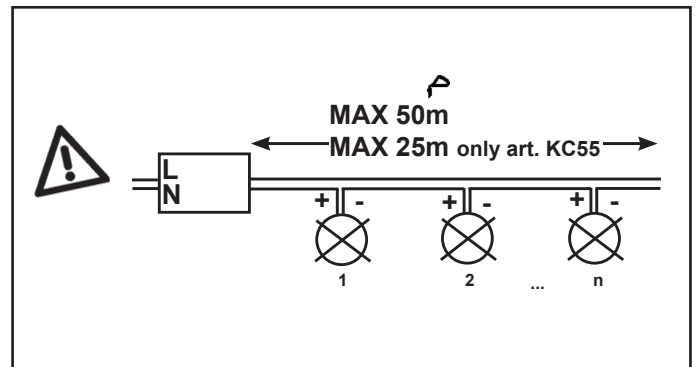

AR في حال تلف الكبل الخارجي المرص، يجب تغييره من قبل المصنع أو من قبل مركز الخدمة المعقول أو من قبل أحد أعضاء الطاقم المتدربين والمؤهلين وذلك لتحاكي إلحاق أي خطر.

IT In caso di danneggiamento del cavo flessibile esterno, questo deve essere sostituito dal costruttore, o dal suo servizio di assistenza, o da personale qualificato equivalente, al fine di evitare pericoli.

EN Should the outer flexible cable be somehow damage, the latter should be replaced by the manufacturer, or by the corresponding service centre, or by an appropriate and qualified member of staff in order to avoid all risk of danger.

ES En caso de daños el cable flexible externo debe substituirse por el fabricante, su servicio de asistencia o personal calificado equivalente para evitar peligros.

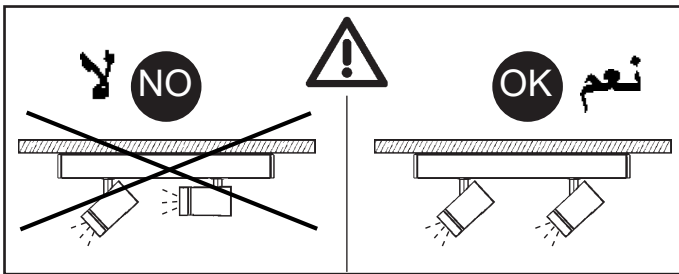

+ Art.

Ø	MZ49		MZ52		MZ48		MZ51		MZ43		MZ45		MZ47		MZ50	
	19 mm	37 mm	19 mm	37 mm	19 mm	37 mm	19 mm	37 mm	19 mm	37 mm	19 mm	37 mm	19 mm	37 mm	19 mm	37 mm
19 mm	×	×	×	×	×	×	×	×	×	×	×	×	×	×	×	×
37 mm	✓	×	✓	×	✓	×	✓	×	✓	×	✓	×	✓	×	✓	×
51 mm	×	✓	×	✓	×	✓	×	✓	×	✓	×	✓	×	✓	×	✓

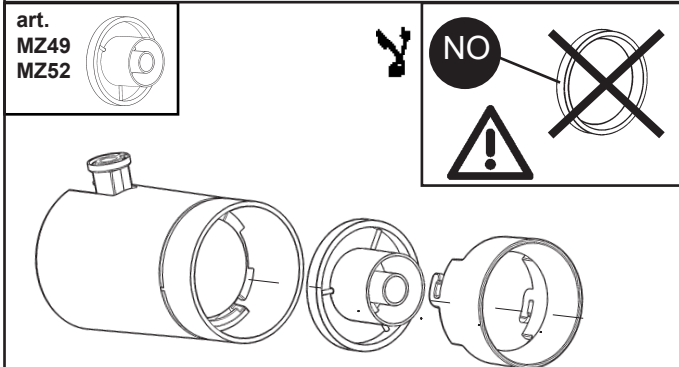
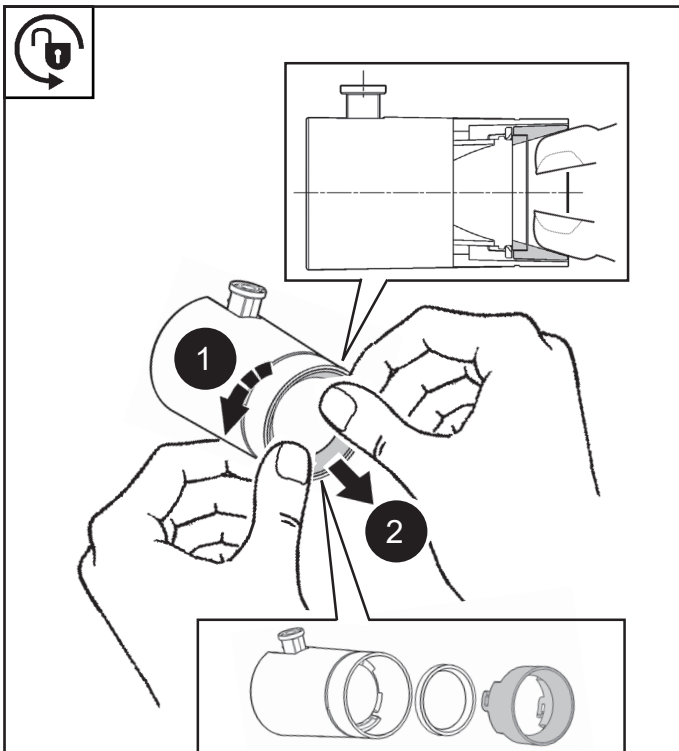

art. MZ49 MZ52

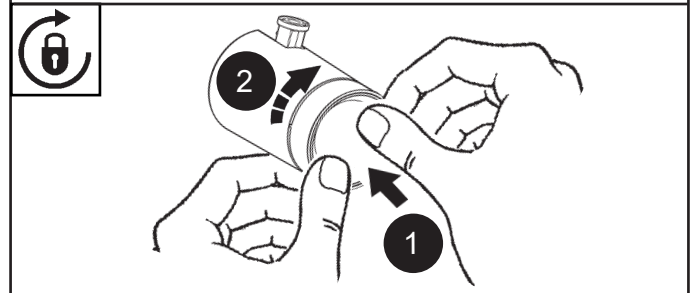
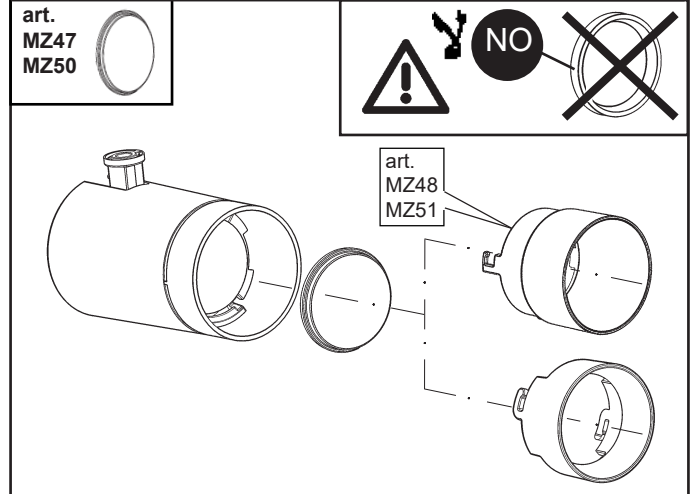
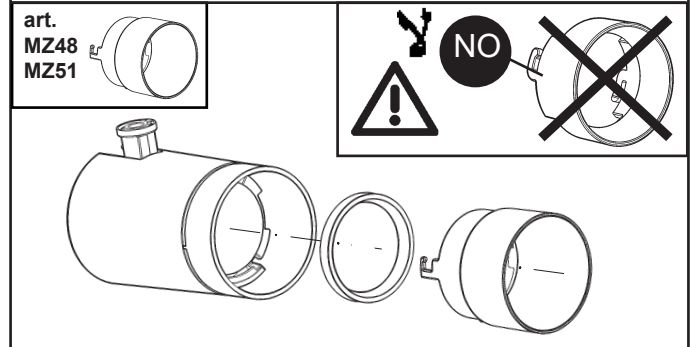
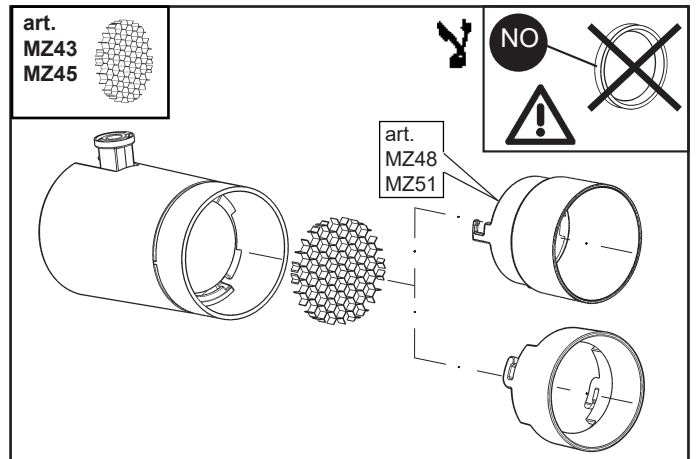

AR . iGuzzini **تنبيه: لاستبدال الضوء LED اتصل بشركة**
 IT N.B.: Per la sostituzione del LED contattare l'azienda iGuzzini.
 EN N.B.: For information on LED replacement please contact iGuzzini.
 ES NOTA: Para sustituir el LED llame a la empresa iGuzzini.

2.510.151.04 IS13430/04		Tensione led Led voltage Tension led Led spanning Led spanning Tensión led led spænding Spänning led Led spänning Led Напряжение 引领电压	Corrente Alimentazione Power Supply current Courant Alimentation Einspeisung Strom Stroomvoorzorging Stroom Corriente Alimentacion Strømforsyning strøm Strømforsyning spenning Elførsörjning strøm ЭЛЕКТРОПИТАНИЕ.ток 电源电流	corrente assorbita absorbed current courant absorbé Stromaufnahme stroomopname corriente absorbida absorberet strøm absorbert strøm tillförd ström поглощаемая мощность 电源电流	fattore di potenza power factor facteur de puissance Leistungsfaktor vermogensfaktor factor de potencia effektfaktor effektfaktor effektfaktor фактор мощности 功率因数	Uout massima del driver remoto Max remote driver Uout Uout maximum du driver déporté Max Uout Remote Driver Maximale Uout van remote driver Uout máxima del controlador remoto Maksimallt Uout for fjern driver Maks Uout ekstern driver Max Uout fjärrstyrd drivenhet Максимальное значение Uвых. дистанционного драйвера 远程驱动器的最大输出电压
ART.		(Vf)	(A)	(A)	λ	(V)
QC12 - QC13 - QC34 - QC35 - QX12 - QX23	2,9	0,7	0,65	0,05	> 0,95	120
QC14 - QC15 - QC36 - QC37 - QX13 - QX24	5,8					
QC16 - QC17 - QC38 - QC39 - QX14 - QX25	8,7					
QC18 - QC19 - QC20 - QC21 - QC40 - QC41 QC42 - QC43 - QX15 - QX16 - QX26 - QX27	12,15					
QC22 - QC23 - QC44 - QC45 - QX17 - QX28	24,3					
QC24 - QC25 - QC46 - QC47 - QX18 - QX29	36,45					
QC30 - QC31 - QC32 - QC33 - QC48 - QC49 QC50 - QC51 - QC52 - QC53 - QC54 - QC55	39,5	0,4				
QC26 - QC27 - QC28 - QC29 - QX19 - QX20 - QX21 - QX22 - QX30 - QX31 - QX32 - QX33	36	0,4	0,05	> 0,95		
QC56 - QC57 - QX38			0,09	> 0,9		
QC58 - QC59 - QX39			0,12	> 0,95		
QC60 - QC61 - QX40			0,07	> 0,95		
QC62 - QC63 - QX41			0,14	> 0,95		
QC64 - QC65 - QX42			0,22	> 0,95		
QC66 - QC67 - QX43						

IT Il modulo LED garantisce una distanza di sicurezza per una Uout max (vedi tabella)

EN The LED module guarantees a safety distance for a max Uout (see table)

FR Le module LED garantit une distance de sécurité pour une Uout max (voir tableau)

DE Das LED-Modul garantiert einen Sicherheitsabstand für einen max. Uout von (s. Tabelle)

NL De ledmodule waarborgt een veilige afstand voor max. Uout (zie tabel)

ES El módulo LED asegura una distancia de seguridad para una Uout máx. (ver la tabla)

DA Lysdiodemodulet garanterer en sikkerhedsafstand for en max Uout (se tabel)

NO LED-modulene garanterer en sikkerhetsavstand for en maks. Uout (se tabell)

SV LED-modulen säkerställer ett säkert avstånd för ett maximalt Uout-värde på (se tabellen)

RU Светодиодный модуль обеспечивает безопасное расстояние для максимального значения Uвых (см. табл.)

ZH LED模块可保证最大输出电压的安全距离 (见表格)

2.510.151.04 IS13430/04		Tensione led Led voltage Tension led Led spanning Led spanning Tensión led led spænding Spänning led Led spänning Led Напряжение 引领电压	Corrente Alimentazione Power Supply current Courant Alimentation Einspeisung Strom Stroomvoorzorging Stroom Corriente Alimentacion Strømforsyning strøm Strømforsyning spenning Elførsörjning strøm ЭЛЕКТРОПИТАНИЕ.ток 电源电流	corrente assorbita absorbed current courant absorbé Stromaufnahme stroomopname corriente absorbida absorberet strøm absorbert strøm tillförd ström поглощаемая мощность 电源电流	fattore di potenza power factor facteur de puissance Leistungsfaktor vermogensfaktor factor de potencia effektfaktor effektfaktor effektfaktor фактор мощности 功率因数	Uout massima del driver remoto Max remote driver Uout Uout maximum du driver déporté Max Uout Remote Driver Maximale Uout van remote driver Uout máxima del controlador remoto Maksimallt Uout for fjern driver Maks Uout ekstern driver Max Uout fjärrstyrd drivenhet Максимальное значение Uвых. дистанционного драйвера 远程驱动器的最大输出电压
ART.		(Vf)	(A)	(A)	λ	(V)
QC12 - QC13 - QC34 - QC35 - QX12 - QX23	2,9	0,7	0,65	0,05	> 0,95	120
QC14 - QC15 - QC36 - QC37 - QX13 - QX24	5,8					
QC16 - QC17 - QC38 - QC39 - QX14 - QX25	8,7					
QC18 - QC19 - QC20 - QC21 - QC40 - QC41 QC42 - QC43 - QX15 - QX16 - QX26 - QX27	12,15					
QC22 - QC23 - QC44 - QC45 - QX17 - QX28	24,3					
QC24 - QC25 - QC46 - QC47 - QX18 - QX29	36,45					
QC30 - QC31 - QC32 - QC33 - QC48 - QC49 QC50 - QC51 - QC52 - QC53 - QC54 - QC55	39,5	0,4				
QC26 - QC27 - QC28 - QC29 - QX19 - QX20 - QX21 - QX22 - QX30 - QX31 - QX32 - QX33	36	0,4	0,05	> 0,95		
QC56 - QC57 - QX38			0,09	> 0,9		
QC58 - QC59 - QX39			0,12	> 0,95		
QC60 - QC61 - QX40			0,07	> 0,95		
QC62 - QC63 - QX41			0,14	> 0,95		
QC64 - QC65 - QX42			0,22	> 0,95		
QC66 - QC67 - QX43						

IT Il modulo LED garantisce una distanza di sicurezza per una Uout max (vedi tabella)

EN The LED module guarantees a safety distance for a max Uout (see table)

FR Le module LED garantit une distance de sécurité pour une Uout max (voir tableau)

DE Das LED-Modul garantiert einen Sicherheitsabstand für einen max. Uout von (s. Tabelle)

NL De ledmodule waarborgt een veilige afstand voor max. Uout (zie tabel)

ES El módulo LED asegura una distancia de seguridad para una Uout máx. (ver la tabla)

DA Lysdiodemodulet garanterer en sikkerhedsafstand for en max Uout (se tabel)

NO LED-modulene garanterer en sikkerhetsavstand for en maks. Uout (se tabell)

SV LED-modulen säkerställer ett säkert avstånd för ett maximalt Uout-värde på (se tabellen)

RU Светодиодный модуль обеспечивает безопасное расстояние для максимального значения Uвых (см. табл.)

ZH LED模块可保证最大输出电压的安全距离 (见表格)

1.154.079.01 IS10181/02

IT N.B.: Per la sostituzione del LED contattare l'azienda iGuzzini.
EN N.B.: For information on LED replacement please contact iGuzzini.
FR N.B.: Pour procéder au remplacement de la LED, adressez-vous à la société iGuzzini.
DE N.B.: Bezüglich des Austausches der LED kontaktieren Sie bitte die Firma iGuzzini.
NL N.B.: Voor het vervangen van de LED neemt u contact op met het bedrijf iGuzzini.
ES NOTA: Para sustituir el LED llame a la empresa iGuzzini.
DA N.B.: For udskiftning af lysdioden, skal man kontakte iGuzzini.
NO N.B.: For informasjon om skifte av LED, vennligst ta kontakt med iGuzzini.
SV OBS! För byte av lysdioden, kontakta företaget iGuzzini.
RU ПРИМЕЧАНИЕ: Для замены СИДов обращайтесь в компанию iGuzzini.
ZH 注意: 如需LED更换的信息, 请联系iGuzzini

AR تنبيه: لاستبدال الضوء LED اتصل بشركة iGuzzini

IT Non fissare la sorgente luminosa durante il suo funzionamento
EN Do not stare at the operating lighting source
FR Ne pas fixer la source lumineuse lorsqu'elle est allumée
DE Die Lichtquelle nicht über längere Zeit mit dem Blick fixieren
NL Bevestig de lichtbron niet terwijl deze in werking is
ES No mire directamente a la fuente luminosa durante el funcionamiento
DA Fastgør ikke lyskilden under dens drift
NO Se ikke direkte på lyskilden når den er i funksjon
SV Fäst inte ljuskällan medan den är i funktion
RU Не смотрите на источник света во время его функционирования
ZH 请勿注视亮着的光源。



AR يجب عدم محاولة تثبيت المصدر الضوئي في أثناء تشغيله.

iGuzzini

IT L'apparecchio dovrebbe essere posizionato in modo che non sia prevista un'osservazione prolungata dell'apparecchio ad una distanza inferiore di 1 m
EN The luminaire should be positioned so that prolonged staring into the luminaire at a distance closer than 1 m is not expected.
FR Il faudrait placer l'appareil de manière à ce qu'aucune observation prolongée de l'appareil ne soit possible à moins de 1 m de distance
DE Das Gerät so positionieren, dass der Anwender nicht über längere Zeit aus weniger als 1 m Abstand angestrahlt wird.
NL Het apparaat moet zodanig geplaatst worden dat er geen langdurige observatie van het apparaat te voorzien is op een afstand van minder dan 1 m
ES El aparato debe emplazarse de manera tal que la observación prolongada se realice a una distancia de al menos 1 m
DA Apparatet skal placeres på et sted, så der ikke kræves en forlængerledning, der er længere end 1 meter
NO Apparatet bør plasseres slik at man ikke behøver å se på det i lengre tid på mindre avstand enn 1 m
SV Apparatet bör plasseres slik at man ikke behøver å se på det i lengre tid på mindre avstånd enn 1 m
RU Прибор следует установить так, чтобы не смотреть на него продолжительное время, если расстояние не достигает 1 м.
ZH 灯具应按照该种方式安置, 以确保其在 1 米以内的距离中可以长时间地不被发现
يجب وضع الجهاز في مكان, بحيث يؤخذ بعين الاعتبار عدم توفر إمكانية مراقبة الجهاز لفترة طويلة, من مسافة أقل من 1 متر.

1.154.079.01 IS10181/02

IT N.B.: Per la sostituzione del LED contattare l'azienda iGuzzini.
EN N.B.: For information on LED replacement please contact iGuzzini.
FR N.B.: Pour procéder au remplacement de la LED, adressez-vous à la société iGuzzini.
DE N.B.: Bezüglich des Austausches der LED kontaktieren Sie bitte die Firma iGuzzini.
NL N.B.: Voor het vervangen van de LED neemt u contact op met het bedrijf iGuzzini.
ES NOTA: Para sustituir el LED llame a la empresa iGuzzini.
DA N.B.: For udskiftning af lysdioden, skal man kontakte iGuzzini.
NO N.B.: For informasjon om skifte av LED, vennligst ta kontakt med iGuzzini.
SV OBS! För byte av lysdioden, kontakta företaget iGuzzini.
RU ПРИМЕЧАНИЕ: Для замены СИДов обращайтесь в компанию iGuzzini.
ZH 注意: 如需LED更换的信息, 请联系iGuzzini

AR تنبيه: لاستبدال الضوء LED اتصل بشركة iGuzzini

IT Non fissare la sorgente luminosa durante il suo funzionamento
EN Do not stare at the operating lighting source
FR Ne pas fixer la source lumineuse lorsqu'elle est allumée
DE Die Lichtquelle nicht über längere Zeit mit dem Blick fixieren
NL Bevestig de lichtbron niet terwijl deze in werking is
ES No mire directamente a la fuente luminosa durante el funcionamiento
DA Fastgør ikke lyskilden under dens drift
NO Se ikke direkte på lyskilden når den er i funksjon
SV Fäst inte ljuskällan medan den är i funktion
RU Не смотрите на источник света во время его функционирования
ZH 请勿注视亮着的光源。



AR يجب عدم محاولة تثبيت المصدر الضوئي في أثناء تشغيله.

iGuzzini

IT L'apparecchio dovrebbe essere posizionato in modo che non sia prevista un'osservazione prolungata dell'apparecchio ad una distanza inferiore di 1 m
EN The luminaire should be positioned so that prolonged staring into the luminaire at a distance closer than 1 m is not expected.
FR Il faudrait placer l'appareil de manière à ce qu'aucune observation prolongée de l'appareil ne soit possible à moins de 1 m de distance
DE Das Gerät so positionieren, dass der Anwender nicht über längere Zeit aus weniger als 1 m Abstand angestrahlt wird.
NL Het apparaat moet zodanig geplaatst worden dat er geen langdurige observatie van het apparaat te voorzien is op een afstand van minder dan 1 m
ES El aparato debe emplazarse de manera tal que la observación prolongada se realice a una distancia de al menos 1 m
DA Apparatet skal placeres på et sted, så der ikke kræves en forlængerledning, der er længere end 1 meter
NO Apparatet bør plasseres slik at man ikke behøver å se på det i lengre tid på mindre avstand enn 1 m
SV Apparatet bör plasseres slik at man ikke behøver å se på det i lengre tid på mindre avstånd enn 1 m
RU Прибор следует установить так, чтобы не смотреть на него продолжительное время, если расстояние не достигает 1 м.
ZH 灯具应按照该种方式安置, 以确保其在 1 米以内的距离中可以长时间地不被发现
يجب وضع الجهاز في مكان, بحيث يؤخذ بعين الاعتبار عدم توفر إمكانية مراقبة الجهاز لفترة طويلة, من مسافة أقل من 1 متر.

1.154.079.01 IS10181/02

IT N.B.: Per la sostituzione del LED contattare l'azienda iGuzzini.
EN N.B.: For information on LED replacement please contact iGuzzini.
FR N.B.: Pour procéder au remplacement de la LED, adressez-vous à la société iGuzzini.
DE N.B.: Bezüglich des Austausches der LED kontaktieren Sie bitte die Firma iGuzzini.
NL N.B.: Voor het vervangen van de LED neemt u contact op met het bedrijf iGuzzini.
ES NOTA: Para sustituir el LED llame a la empresa iGuzzini.
DA N.B.: For udskiftning af lysdioden, skal man kontakte iGuzzini.
NO N.B.: For informasjon om skifte av LED, vennligst ta kontakt med iGuzzini.
SV OBS! För byte av lysdioden, kontakta företaget iGuzzini.
RU ПРИМЕЧАНИЕ: Для замены СИДов обращайтесь в компанию iGuzzini.
ZH 注意: 如需LED更换的信息, 请联系iGuzzini

AR تنبيه: لاستبدال الضوء LED اتصل بشركة iGuzzini

IT Non fissare la sorgente luminosa durante il suo funzionamento
EN Do not stare at the operating lighting source
FR Ne pas fixer la source lumineuse lorsqu'elle est allumée
DE Die Lichtquelle nicht über längere Zeit mit dem Blick fixieren
NL Bevestig de lichtbron niet terwijl deze in werking is
ES No mire directamente a la fuente luminosa durante el funcionamiento
DA Fastgør ikke lyskilden under dens drift
NO Se ikke direkte på lyskilden når den er i funksjon
SV Fäst inte ljuskällan medan den är i funktion
RU Не смотрите на источник света во время его функционирования
ZH 请勿注视亮着的光源。



AR يجب عدم محاولة تثبيت المصدر الضوئي في أثناء تشغيله.

iGuzzini

IT L'apparecchio dovrebbe essere posizionato in modo che non sia prevista un'osservazione prolungata dell'apparecchio ad una distanza inferiore di 1 m
EN The luminaire should be positioned so that prolonged staring into the luminaire at a distance closer than 1 m is not expected.
FR Il faudrait placer l'appareil de manière à ce qu'aucune observation prolongée de l'appareil ne soit possible à moins de 1 m de distance
DE Das Gerät so positionieren, dass der Anwender nicht über längere Zeit aus weniger als 1 m Abstand angestrahlt wird.
NL Het apparaat moet zodanig geplaatst worden dat er geen langdurige observatie van het apparaat te voorzien is op een afstand van minder dan 1 m
ES El aparato debe emplazarse de manera tal que la observación prolongada se realice a una distancia de al menos 1 m
DA Apparatet skal placeres på et sted, så der ikke kræves en forlængerledning, der er længere end 1 meter
NO Apparatet bør plasseres slik at man ikke behøver å se på det i lengre tid på mindre avstand enn 1 m
SV Apparatet bör plasseres slik at man ikke behøver å se på det i lengre tid på mindre avstånd enn 1 m
RU Прибор следует установить так, чтобы не смотреть на него продолжительное время, если расстояние не достигает 1 м.
ZH 灯具应按照该种方式安置, 以确保其在 1 米以内的距离中可以长时间地不被发现
يجب وضع الجهاز في مكان, بحيث يؤخذ بعين الاعتبار عدم توفر إمكانية مراقبة الجهاز لفترة طويلة, من مسافة أقل من 1 متر.

2.509.663.00 IS18972/00	iGuzini	الجهد الكهربائي Tensione led Led voltage Tensión led	التيار الكهربائي لمزود الطاقة Corrente Alimentazione Power Supply current Corriente Alimentacion	التيار الممتص corrente assorbita absorbed current corriente absorbida	عامل القدرة fattore di potenza power factor factor de potencia	أقصى مخرج لوحدة المُشغِّل البعيد Uout massima del driver remoto Max remote driver Uout Uout máxima del controlador remoto	
الصنف ART.	(Vf)	(A)	(A)	λ	(V)		
QC12 - QC13 - QC34 - QC35 - QX12 - QX23	2,9	0,7				120	
QC14 - QC15 - QC36 - QC37 - QX13 - QX24	5,8						
QC16 - QC17 - QC38 - QC39 - QX14 - QX25	8,7						
QC18 - QC19 - QC20 - QC21 - QC40 - QC41 QC42 - QC43 - QX15 - QX16 - QX26 - QX27	12,15	0,65					
QC22 - QC23 - QC44 - QC45 - QX17 - QX28	24,3						
QC24 - QC25 - QC46 - QC47 - QX18 - QX29	36,45						
QC30 - QC31 - QC32 - QC33 - QC48 - QC49 QC50 - QC51 - QC52 - QC53 - QC54 - QC55	39,5	0,4					
QC26 - QC27 - QC28 - QC29 - QX19 - QX20 - QX21 - QX22 - QX30 - QX31 - QX32 - QX33	36	0,4					
QC56 - QC57 - QX38			0,05	> 0,95			
QC58 - QC59 - QX39			0,09	> 0,9			
QC60 - QC61 - QX40			0,12	> 0,95			
QC62 - QC63 - QX41			0,07	> 0,95			
QC64 - QC65 - QX42			0,14	> 0,95			
QC66 - QC67 - QX43			0,22	> 0,95			

وحدة مؤشر "ليد" تضمن مسافة أمان للحصول على أقصى مخرج للوحدة (انظر الجدولة) AR

IT Il modulo LED garantisce una distanza di sicurezza per una Uout max (vedi tabella)

EN The LED module guarantees a safety distance for a max Uout (see table)

ES El módulo LED asegura una distancia de seguridad para una Uout máx. (ver la tabla)

2.509.663.00 IS18972/00	iGuzini	الجهد الكهربائي Tensione led Led voltage Tensión led	التيار الكهربائي لمزود الطاقة Corrente Alimentazione Power Supply current Corriente Alimentacion	التيار الممتص corrente assorbita absorbed current corriente absorbida	عامل القدرة fattore di potenza power factor factor de potencia	أقصى مخرج لوحدة المُشغِّل البعيد Uout massima del driver remoto Max remote driver Uout Uout máxima del controlador remoto	
الصنف ART.	(Vf)	(A)	(A)	λ	(V)		
QC12 - QC13 - QC34 - QC35 - QX12 - QX23	2,9	0,7				120	
QC14 - QC15 - QC36 - QC37 - QX13 - QX24	5,8						
QC16 - QC17 - QC38 - QC39 - QX14 - QX25	8,7						
QC18 - QC19 - QC20 - QC21 - QC40 - QC41 QC42 - QC43 - QX15 - QX16 - QX26 - QX27	12,15	0,65					
QC22 - QC23 - QC44 - QC45 - QX17 - QX28	24,3						
QC24 - QC25 - QC46 - QC47 - QX18 - QX29	36,45						
QC30 - QC31 - QC32 - QC33 - QC48 - QC49 QC50 - QC51 - QC52 - QC53 - QC54 - QC55	39,5	0,4					
QC26 - QC27 - QC28 - QC29 - QX19 - QX20 - QX21 - QX22 - QX30 - QX31 - QX32 - QX33	36	0,4					
QC56 - QC57 - QX38			0,05	> 0,95			
QC58 - QC59 - QX39			0,09	> 0,9			
QC60 - QC61 - QX40			0,12	> 0,95			
QC62 - QC63 - QX41			0,07	> 0,95			
QC64 - QC65 - QX42			0,14	> 0,95			
QC66 - QC67 - QX43			0,22	> 0,95			

وحدة مؤشر "ليد" تضمن مسافة أمان للحصول على أقصى مخرج للوحدة (انظر الجدولة) AR

IT Il modulo LED garantisce una distanza di sicurezza per una Uout max (vedi tabella)

EN The LED module guarantees a safety distance for a max Uout (see table)

ES El módulo LED asegura una distancia de seguridad para una Uout máx. (ver la tabla)

- I Istruzioni per le operazioni di servizio per l'apparecchio di illuminazione**
GB Instructions on luminaire service operations
F Instructions pour les opérations de service du luminaire
D Wartungsanleitung für die Leuchte
NL Instructies voor de onderhoudsoperaties op de verlichtingsarmatuur
E Instrucciones para las operaciones de servicio del aparato de alumbrado
DK Anvisninger i serviceindgreb på belysningsarmatur
N Anvisninger for betjening av lysapparatet
S Instruktioner för användning av belysningsanordningen
RUS Инструкции по эксплуатации осветительного прибора
CN 照明装置检修操作说明

Sostituire la lampada parzialmente esausta
 Replace the partly exhausted lamp
 Remplacer la lampe partiellement épuisée
 Die teilweise erschöpfte Lampe austauschen
 Vervang de gedeeltelijk lege lamp
 Sustituir la lámpara parzialmente agotada
 Udskift den delvist udtjente pære
 Skifte ut den delvis utbrænte lyspæren
 Byt ut den delvis förbrukade lampan
 Замена частично отработанной лампочки
 更换部分老化的灯泡

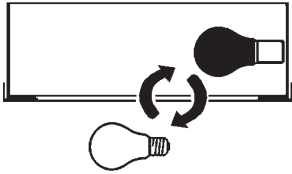

Spegnimento
 Switch it off
 Extinction
 Ausschaltung
 Uitschakeling
 Apagado
 Slukking
 Slukking
 Släckning
 Выключение
 关灯

Interrompere l'alimentazione dell'apparecchio
 Cut the power supply to the luminaire
 Couper l'alimentation du luminaire
 Stromversorgung der Leuchte unterbrechen
 Onderbreek de voeding van het apparaat
 Interrumpir la alimentación del aparato
 Afbryd armaturets strømforsyning
 Avbryte strømtilførselen til apparatet
 Koppla från anordningens strömförsörjning
 Отключить электропитание прибора
 中断装置供电

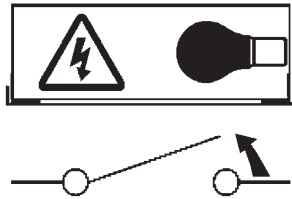

Aprire l'apparecchio
 Open the fixture
 Ouvrir le luminaire
 Das Gerät öffnen
 Open het apparaat
 Abrir el aparato
 Åbn armaturet
 Åpne apparatet
 Öppna anordningen
 Раскрыть прибор
 打开装置

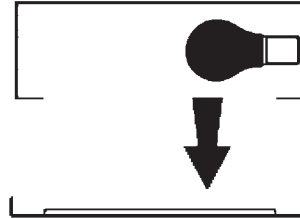

Rimuovere la lampada esausta
 Remove the exhausted lamp
 Retirer la lampe épuisée
 Die alte Lampe entnehmen
 Verwijder de lege lamp
 Quitar la lámpara agotada
 Tag den udtjente pære ud
 Fjerne den utbrænte lyspæren
 Ta bort den förbrukade lampan
 Вынуть старую лампочку
 取出老化的灯泡

Portarla in un centro di riciclaggio
 Carry it to a recycling centre
 La porter dans une déchetterie pour son recyclage
 Ordnungsgemäß entsorgen
 Breng de lamp naar een recyclingcentrum
 Llevarla a un centro de reciclaje
 Aflever den på en genbrugsstation
 Lever den til en miljøstasjon
 Lämna in den till en återvinningsanläggning
 Сдать ее в пункт приема утильсырья
 将其送往回收中心

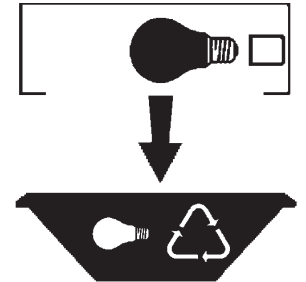

Inserire la nuova lampada
 Introduce the new lamp
 Installer la lampe neuve
 Die neue Lampe einsetzen
 Doe de nieuwe lamp op zijn plek
 Montar la nueva lámpara
 Sæt den nye pære i
 Sette i den nye pæren
 Sätt i den nya lampan
 Вставить новую лампочку
 装入新灯泡

Inserire la nuova lampada nel portalampana
 Fit the new lamp into the socket
 Installer la nouvelle lampe dans le support de lampe
 Die neue Lampe in den Sockel einsetzen
 Doe de nieuwe lamp in de lamphouder
 Montar la nueva lámpara en el portalampana
 Sæt den nye pære i fatningen
 Sette den nye pæren inn i lampeholderen
 Sätt i den nya lampan i lamphållaren
 Вставить новую лампочку в патрон
 将新灯泡插入灯泡架中

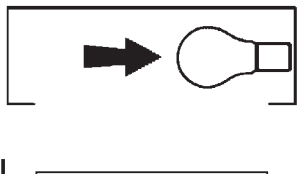

Riposizionare ottica
 Re-place the optic
 Remettre l'optique à sa place
 Die Optik wieder einsetzen
 Doe de optiek weer op zijn plaats
 Volver a montar la óptica
 Sæt den optiske enhed på plads
 Innstille linsen
 Flytta om optiken
 Отрегулировать линзы
 重新定位光头

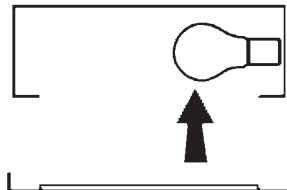

Effettuare prova di funzionamento
 Perform operative test
 Procéder à un essai de fonctionnement
 Eine Funktionsprüfung durchführen
 Controleer de correcte werking
 Hacer una prueba de funcionamiento
 Afprøv funktionen
 Prové om den fungerer
 Utför funktionstest
 Выполнить проверку исправности работы
 执行功能测试

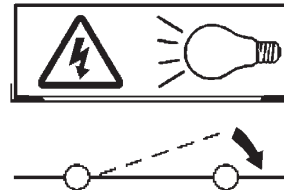

- I Istruzioni per la pulizia dell'apparecchio di illuminazione
 GB Instructions on luminaire cleaning operations
 F Instructions pour le nettoyage du luminaire
 D Anweisungen zur Reinigung der Leuchte
 NL Instructies voor de reiniging van de verlichtingsarmatuur
 E Instrucciones para limpiar el aparato de alumbrado
 DK Anvisninger i rengøring af belysningsarmaturet
 N Anvisninger for rengjøring av lysapparatet
 S Instruktioner för rengöring av belysningsanordningen
 RUS Инструкции по чистке осветительного прибора
 CN 照明装置清洁说明

Pulire l'apparecchio
 Clean the fixture
 Nettoyer le luminaire
 Das Gerät reinigen
 Reinig het apparaat
 Limpiar el aparato
 Rengør armaturet
 Rengjøre apparatet
 Rengör anordningen
 Чистка прибора
 清洁装置



Spegnimento
 Switch it off
 Extinction
 Ausschaltung
 Uitschakeling
 Apagado
 Slukning
 Slukking
 Släckning
 Выключение
 关灯

Interrompere l'alimentazione dell'apparecchio
 Cut the power supply to the luminaire
 Couper l'alimentation du luminaire
 Stromversorgung der Leuchte unterbrechen
 Onderbreek de voeding van het apparaat
 Interrumpir la alimentación del aparato
 Afbryd armaturets strømforsyning
 Avbryt strømtilførselen til apparatet
 Koppla från anordningens strömförsörjning
 Отключить электропитание прибора
 中断装置供电



Spolverare l'ottica esterna
 Remove dust from the external optic
 Dépoussiérer l'optique extérieure
 Die externe Optik abstauben
 Stof de externe optiek af
 Quitar el polvo de la óptica exterior
 Tør støvet af den udvendige optiske enhed
 Fjerne støv fra den eksterne lysenheden
 Damma av den yttre optiken
 Вытереть пыль с внешней стороны линз
 为外侧镜头掸尘



Lavare l'ottica esterna
 Wash the external optic
 Laver l'optique extérieure
 Die externe Optik waschen
 Was de externe optiek
 Lavar la óptica exterior
 Vask den udvendige optiske enhed
 Vaske den eksterne lysenheden
 Rengör den yttre optiken
 Вымыть линзы с внешней стороны
 清洁外镜头



Rimuovere l'ottica
 Remove the optic
 Retirer l'optique
 Die Optik abnehmen
 Verwijder de optiek
 Quitar la óptica
 Tag den optiske enhed af
 Fjerne lysenheden
 Ta bort optiken
 Снять линзы
 取下镜头



Pulire la parte interna dell'apparecchio di illuminazione
 Clean the inside of the fixture
 Nettoyer l'intérieur du luminaire
 Die Innenseite der Leuchte reinigen
 Reinig de binnenzijde van de verlichtingsarmatuur
 Limpiar el interior del aparato de alumbrado
 Rengør belysningsarmaturets indvendige dele
 Rengjøre lysapparatet innvendig
 Rengör belysningsanordningen invändigt
 Протереть осветительный прибор изнутри
 清洁照明装置内部



Riposizionare ottica
 Re-place the optic
 Remettre l'optique à sa place
 Die Optik wieder einsetzen
 Doe de optiek weer op zijn plaats
 Volver a montar la óptica
 Sæt den optiske enhed på plads
 Innstille linsen
 Flytta om optiken
 Отрегулировать линзы
 重新定位镜头



Effettuare prova di funzionamento
 Perform operative test
 Procéder à un essai de fonctionnement
 Eine Funktionsprüfung durchführen
 Controleer de correcte werking
 Hacer una prueba de funcionamiento
 Afprøv funktionen
 Prøve om den fungerer
 Utför funktionstest
 Выполнить проверку исправности работы
 执行功能测试



- I Istruzioni per il fine vita e lo smaltimento dei componenti**
GB Instructions on end-of-life and component disposal
F Instructions pour la gestion des composants en fin de vie et leur mise au rebut
D Anweisungen zur Entsorgung der Leuchtenkomponenten
NL Instructies voor het verwijderen van de armatuur en het recyclen van de onderdelen
E Instrucciones para el final de vida y la eliminación los componentes
DK Anvisninger i udtjent armatur og bortskaffelse af komponenter
N Anvisninger for endt levetid og avfallsbehandling av delene
S Instruktionser vid bortskaffning och kassering av komponenter
RUS Инструкции по утилизации прибора и его комплектующих по окончании его срока службы
CN 寿命期结束与零件废弃处置说明

Spegnimento
Switch it off
Extinction
Ausschaltung
Uitschakeling
Apagado
Slukning
Slukking
Släckning
Выключение
关灯

Interrompere l'alimentazione dell'apparecchio
Cut the power supply to the luminaire
Couper l'alimentation du luminaire
Stromversorgung der Leuchte unterbrechen
Onderbreek de voeding van het apparaat
Interrompirla alimentación del aparato
Afbryd armaturets strømforsyning
Avbryt strømtilførselen til apparatet
Koppla från anordningens strömförsörjning
Отключить электропитание прибора
中断装置供电



Rimuovere la/e lampada/e per la dismissione
Remove the lamp(s) for decommissioning
Retirer la(les) lampe(s) pour sa(leur) mise au rebut
Die Lampe/n ordnungsgemäß entsorgen
Verwijder de lamp(en) voor het recyclen
Quitar la(s) lámpara(s) para el desecho
Tag pæren/pærerne ud til bortskaffelse
Fjerne lampen/-e som skal kastes
Ta bort lampan/-orna för bortskaffningen
Вынуть лампочку/и для утилизации прибора
取出需要丢弃的灯泡



Rimuovere la batteria per la dismissione
Remove the battery for decommissioning
Retirer la batterie pour sa mise au rebut
Die Batterie ordnungsgemäß entsorgen
Verwijder de batterij voor het recyclen
Quitar la batería para el desecho
Tag batteriet ud til bortskaffelse
Fjerne batteriet som skal kastes
Ta bort batteriet för bortskaffningen
Вынуть батарейку для утилизации прибора
取出需要丢弃的电池

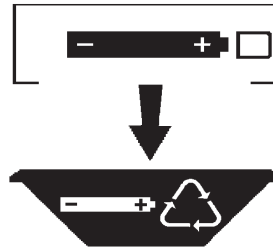

Rimuovere l'apparecchio per la dismissione
Remove the fixture for decommissioning
Enlever le luminaire pour sa mise au rebut
Das Gerät ordnungsgemäß entsorgen
Verwijder het apparaat voor het recyclen
Quitar el aparato para el desecho
Tag armaturet ud til bortskaffelse
Fjerne apparatet som skal kastes
Ta bort anordningen för bortskaffningen
Снять прибор для утилизации
取出需要丢弃的装置



Inviare i materiali ad un centro di raccolta
RAEE
Send the materials to a WEEE collection
centre
Envoyer les matériaux dans une déchetterie
DEEE
Die Materialien in einem WEEE-Zentrum
entsorgen
Zend de materialen naar een recyclingscentrum
voor de AEEA
Enviar los materiales a un centro de recogida
RAEE
Afløver materialerne på et indsamlingscenter
for elektronisk udstyr
Sende materialene til en miljøstasjon for
resirkulering av EE-avfall
Skicka materialet till en RAEE uppsamlingscentral
Сдать материалы в пункт приема утильсырья
将材料送往电气和电子垃圾回收中心

